



► **Katherm HK**  
Trench Heating

# Katherm HK

Heating or cooling with energy-efficient EC tangential fans

► **Technical catalogue**



# Contents

<b>01 ▶ Product information</b>	<b>6</b>
▶ Overview	7
▶ Product data	8
▶ Selection guide: overview of models	9
▶ Katherm HK at a glance	10
▶ Grilles	12
▶ Katherm HK optionally with supply air function – Supply air modules – Supply air ducts	14
<b>02 ▶ Technical data</b>	<b>18</b>
▶ Advice on measuring conditions	19
▶ Katherm HK 320, 2-pipe, trench height 130 mm	20
▶ Katherm HK 320, 4-pipe, trench height 130 mm	22
▶ Katherm HK 290, 2-pipe, trench height 160 mm	24
▶ Katherm HK 290, 4-pipe, trench height 160 mm	26
▶ Katherm HK 360, 2-pipe, trench height 210 mm	28
▶ Katherm HK 360, 4-pipe, trench height 210 mm	30
<b>03 ▶ Design information</b>	<b>32</b>
▶ Information on planning and design	33
▶ Water connections – Pipe openings	34
<b>04 ▶ Controls</b>	<b>36</b>
▶ 24 V electromechanical model	36
▶ 230 V electromechanical model	38
▶ KaControl model	43
<b>05 ▶ Ordering information</b>	<b>48</b>
▶ Katherm HK	48
▶ Accessories	49



A photograph of a modern interior space, likely a hallway or lounge area. The room features a large, curved window with a black frame, offering a view of a multi-story building with a glass facade. The floor is made of light-colored wood. A large, white, cylindrical pillar stands in the foreground. The ceiling is white with recessed lighting. A blue text box is overlaid on the left side of the image.

Katherm HK:  
On-demand  
heating and cooling  
from the floor,  
individually  
controlled.





A special design of Katherm HK trench heaters with energy-efficient EC tangential fans ensures quiet operation and energy-savings in the new ADAC head office in Munich (Germany). This design of trench unit produces demand-led filtered, heated or cooled recirculating air from the floor.

Katherm HK and Katherm HK empty ducts are individually adapted to the curved external façade in this building.



# 01 ▶ Product information

---





## Katherm HK – decentralised room air conditioning from the floor

Heaters positioned in front of windows are often unacceptable for aesthetic reasons in modern offices and other buildings with large glazed windows. At the same time, the needs of the users with regard to the climate in the space also increase.

The demand-led supply of filtered, heated or cooled recirculating air with Katherm HK solves both problems at the same time, practically and invisibly from the floor. A higher level of efficiency is achieved with energy efficient EC tangential fans with noise-optimised commutation electronics, resulting in energy-savings of up to 60% compared with conventional fans!

Flow-optimised barrel impellers ensure quiet operation and guarantee that air flows through the convector along its entire length.

### EC technology

EC fans can be operated infinitely variably within a low fan speed range even at low air volumes with intelligent, integrated electronics on demand and this energy-efficiently. Low fan speeds have a positive effect on noise levels in areas, like offices, where the noise levels lie far below the audible threshold or the usual measuring range.

Katherm HK are available ex-works with integral KaControl. The KaController room control unit enables up to six units in a group to be operated stand-alone. The units can be integrated into higher-level automation systems, such as KNX, Modbus or LON, via optional interfaces. There is also a control option with a 0-10 V fan control if complete control is to be provided on site.

### Example of cooling unit

(Installed in screed, Katherm HK 320, trench height 130 mm)

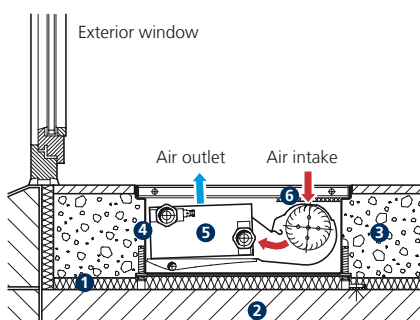

- 1 Heat and sound insulation
- 2 Concrete floor
- 3 Screed
- 4 Floor trench
- 5 High-output convector
- 6 Filter (optional)

### Example of heating unit

(Installed in a raised floor, Katherm HK 290, trench height 160 mm)

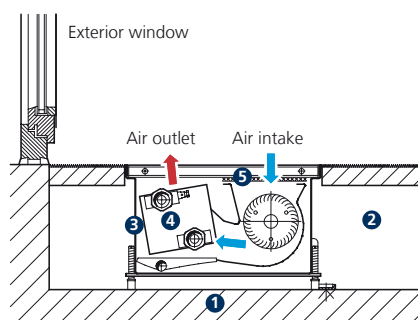

- 1 Concrete floor
- 2 False floor
- 3 Floor trench
- 4 High-output convector
- 5 Filter (optional)

### Example of cooling unit

(Installed in a raised floor, Katherm HK 360, trench height 210 mm)

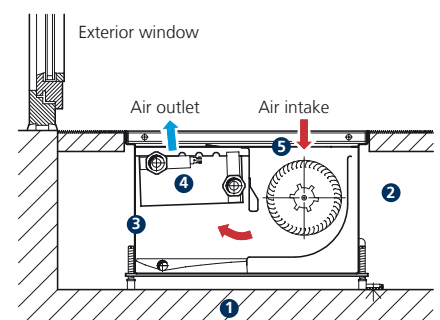

- 1 Concrete floor
- 2 False floor
- 3 Floor trench
- 4 High-output convector
- 5 Filter (optional)

## Product data



### Product advantages

- ▶ heating and cooling selectable as 2-pipe and 4-pipe system
- ▶ simple cleaning in accordance with the Hygiene Directive VDI 6022
- ▶ whisper-quiet, highly efficient EC tangential fan

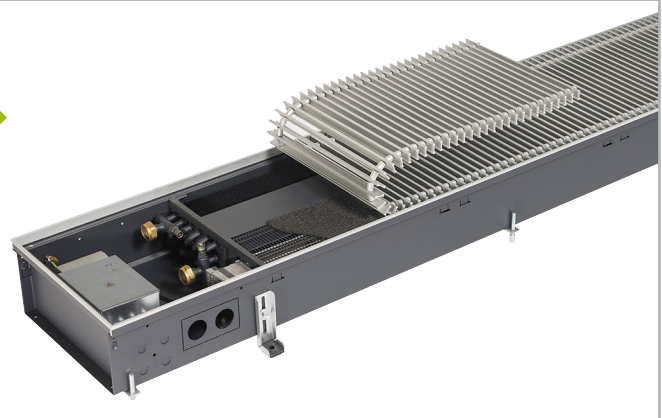

### Features

#### Standard range

**Katherm HK 320:** 1 trench width, 1 trench height, 6 trench lengths

**Katherm HK 290:** 1 trench width, 1 trench height, 6 trench lengths

**Katherm HK 360:** 1 trench width, 1 trench height, 5 trench lengths. Notwithstanding the standard range (NP), the products can also be individually manufactured in line with the non-standard programme (MP).

- Convection** ▶ EC tangential fan
- Heating** ▶ LPHW
- Cooling** ▶ CHW
- Ventilation** ▶ supply air models on request
- KaControl System** ▶ optional
- ▶ 2-pipe
- ▶ 4-pipe

#### Grille finishes

- ▶ roll-up grilles
- ▶ linear grilles

### Performance data

#### Heat output<sup>1)</sup> [W]

- ▶ 544 – 16884

#### Cooling output<sup>2)</sup> [W]

- ▶ 85 – 3348

#### Sound pressure level<sup>3)</sup> [dB(A)]

- ▶ < 20 – 55

#### Sound power level [dB(A)]

- ▶ < 28 – 63

### Applications

Buildings of all kinds, in which there is a high cooling load due to internal loads and the effects of sunlight. Experience has shown that Katherm HK can provide low-cost, effective cooling with low, non-disruptive sound levels.



Hotels/  
motels



Sales rooms  
and  
showrooms



Office and  
meeting  
rooms



Homes and  
conservatories



Restaurants  
and cafés

<sup>1)</sup> at LPHW 75 / 65,  $t_{L1} = 20^\circ\text{C}$ , with fan-assisted convection

<sup>2)</sup> at CHW 16 / 18,  $t_{L1} = 27^\circ\text{C}$ , 48% relative humidity, with fan-assisted convection

<sup>3)</sup> The sound pressure levels were calculated with an assumed room insulation of 8 dB(A). This corresponds to a distance of 2 m, a room volume of 100 m<sup>3</sup> and a reverberation time of 0.5 s (in accordance with VDI 2081).



# Selection guide: overview of models

Design	Trench width	Trench height	2/4-pipe	Trench length	Heat output <sup>1)</sup>	Cooling output <sup>2)</sup>	Sound pressure level <sup>3)</sup>	Sound power level	Further information
	[mm]	[mm]		[mm]	[W]	[W]	[dB(A)]	[dB(A)]	
HK 320	320	130	2-pipe	915	706–2101	87–356	<20 <sup>4)</sup> –39	<28 <sup>4)</sup> –47	▶ Page 20
				1200	1102–3627	160–630	<20 <sup>4)</sup> –41	<28 <sup>4)</sup> –49	
				1700	2149–6043	279–1043	<20 <sup>4)</sup> –41	<28 <sup>4)</sup> –49	
				2000	2321–7573	312–1326	<20 <sup>4)</sup> –44	<28 <sup>4)</sup> –52	
				2500	3336–10103	432–1749	<20 <sup>4)</sup> –44	<28 <sup>4)</sup> –52	
				3000	4266–12553	551–2159	<20 <sup>4)</sup> –44	<28 <sup>4)</sup> –52	
	4-pipe	915	544–1220	85–337	<20 <sup>4)</sup> –39	<28 <sup>4)</sup> –47	▶ Page 22		
		1200	954–2185	161–620	<20 <sup>4)</sup> –41	<28 <sup>4)</sup> –49			
		1700	1766–3785	280–1027	<20 <sup>4)</sup> –41	<28 <sup>4)</sup> –49			
		2000	2110–4884	314–1307	<20 <sup>4)</sup> –44	<28 <sup>4)</sup> –52			
		2500	2822–6415	433–1722	<20 <sup>4)</sup> –44	<28 <sup>4)</sup> –52			
		3000	3611–8004	552–2124	<20 <sup>4)</sup> –44	<28 <sup>4)</sup> –52			
HK 290	290	160	2-pipe	950	673–2811	75–534	<20 <sup>4)</sup> –39	<28 <sup>4)</sup> –47	▶ Page 24
				1200	1137–4752	127–903	<20 <sup>4)</sup> –42	<28 <sup>4)</sup> –50	
				1700	1810–7562	202–1437	<20 <sup>4)</sup> –44	<28 <sup>4)</sup> –52	
				2000	2370–9905	265–1882	<20 <sup>4)</sup> –45	<28 <sup>4)</sup> –53	
				2500	3027–12648	338–2404	<20 <sup>4)</sup> –46	<28 <sup>4)</sup> –54	
				3000	4036–16865	451–3205	<20 <sup>4)</sup> –47	<28 <sup>4)</sup> –55	
	4-pipe	950	564–1586	72–495	<20 <sup>4)</sup> –39	<28 <sup>4)</sup> –47	▶ Page 26		
		1200	954–2681	121–837	<20 <sup>4)</sup> –42	<28 <sup>4)</sup> –50			
		1700	1518–4268	193–1332	<20 <sup>4)</sup> –44	<28 <sup>4)</sup> –52			
		2000	1988–5590	253–1744	<20 <sup>4)</sup> –45	<28 <sup>4)</sup> –53			
		2500	2539–7138	323–2228	<20 <sup>4)</sup> –46	<28 <sup>4)</sup> –54			
		3000	3385–9517	431–2970	<20 <sup>4)</sup> –47	<28 <sup>4)</sup> –55			
HK 360	360	210	2-pipe	950	887–4113	92–816	<20 <sup>4)</sup> –51	<28 <sup>4)</sup> –59	▶ Page 28
				1200	1471–6819	152–1352	<20 <sup>4)</sup> –52	<28 <sup>4)</sup> –60	
				1350	1821–8442	189–1674	<20 <sup>4)</sup> –52	<28 <sup>4)</sup> –60	
				1850	2755–12771	286–2533	<20 <sup>4)</sup> –53	<28 <sup>4)</sup> –61	
				2250	3642–16884	378–3348	<20 <sup>4)</sup> –55	<28 <sup>4)</sup> –63	
				4-pipe	950	643–2982	87–768	<20 <sup>4)</sup> –51	
	1200	1066–4944	144–1273	<20 <sup>4)</sup> –52	<28 <sup>4)</sup> –60				
	1350	1320–6121	178–1576	<20 <sup>4)</sup> –52	<28 <sup>4)</sup> –60				
	1850	1998–9261	269–2385	<20 <sup>4)</sup> –53	<28 <sup>4)</sup> –61				
	2250	2641–12243	356–3153	<20 <sup>4)</sup> –55	<28 <sup>4)</sup> –63				

## Sectional views

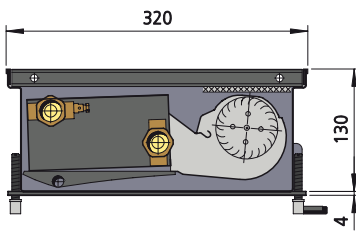

Katherm HK 320, trench height 130 mm

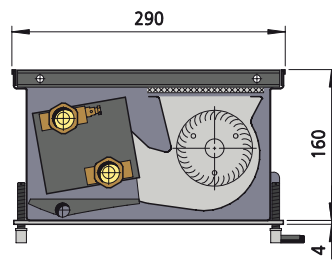

Katherm HK 290, trench height 160 mm

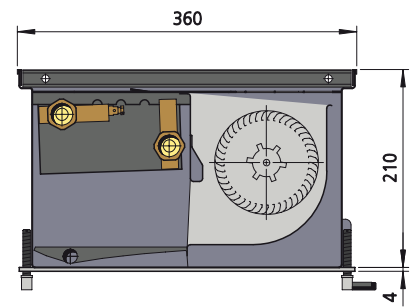

Katherm HK 360, trench height 210 mm

<sup>1)</sup> at LPHW 75/65, t<sub>L1</sub> = 20 °C, with fan-assisted convection

<sup>2)</sup> at CHW 16 / 18, t<sub>L1</sub> = 27 °C, 48% relative humidity, with fan-assisted convection

<sup>3)</sup> The sound pressure levels were calculated with an assumed room insulation of 8 dB(A). This corresponds to a distance of 2 m, a room volume of 100 m<sup>3</sup> and a reverberation time of 0.5 s (in accordance with VDI 2081).

<sup>4)</sup> Sound pressure level < 20 dB (A) and sound power level < 28 dB (A) outside the usual measuring and audible range.

# Katherm HK at a glance

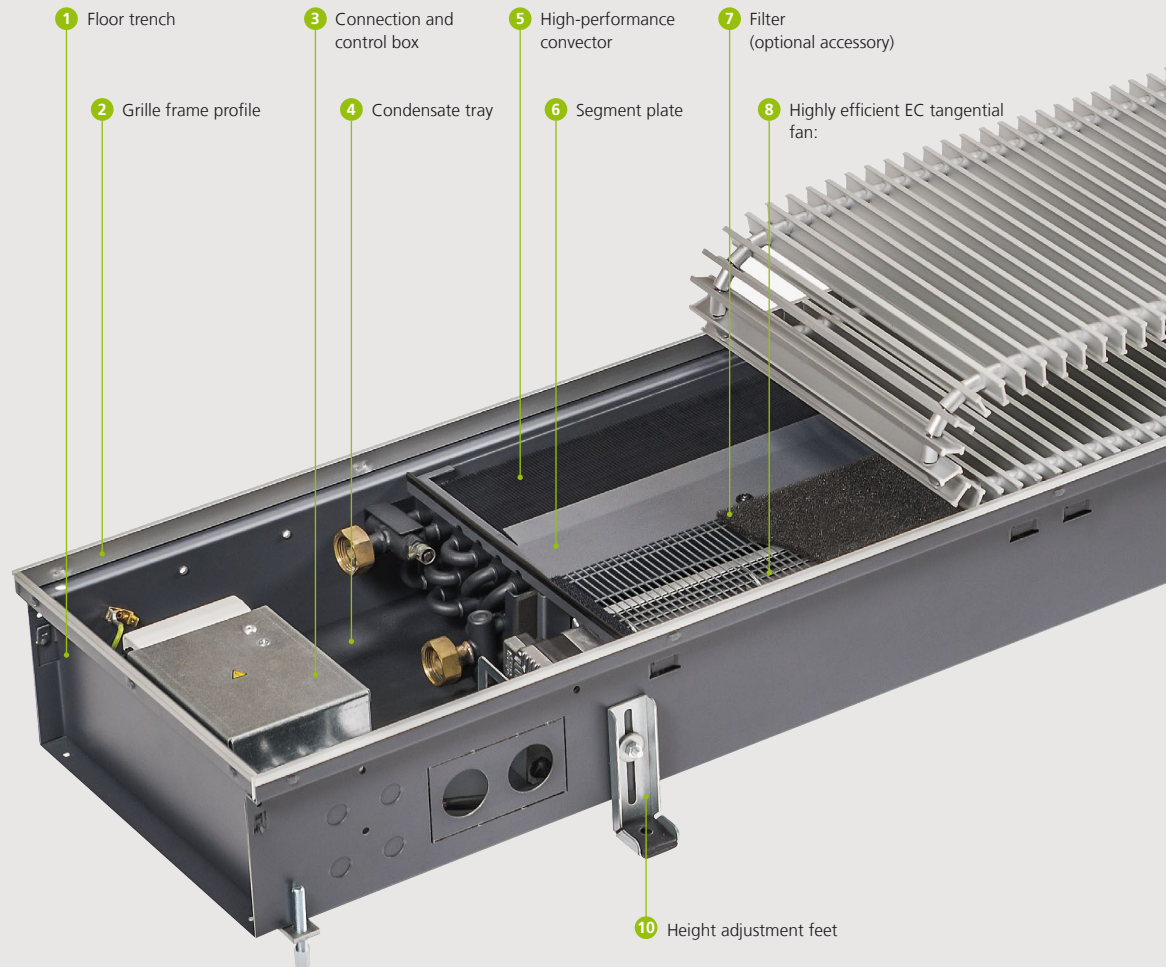

## Features

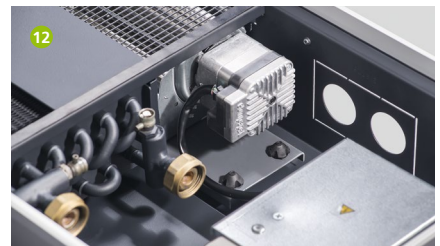
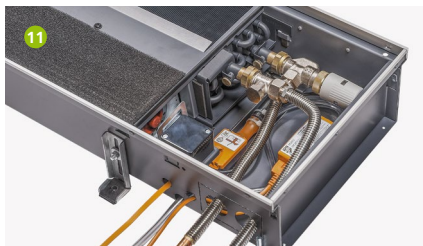
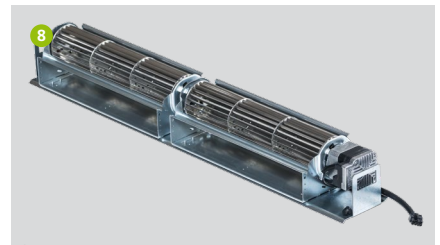



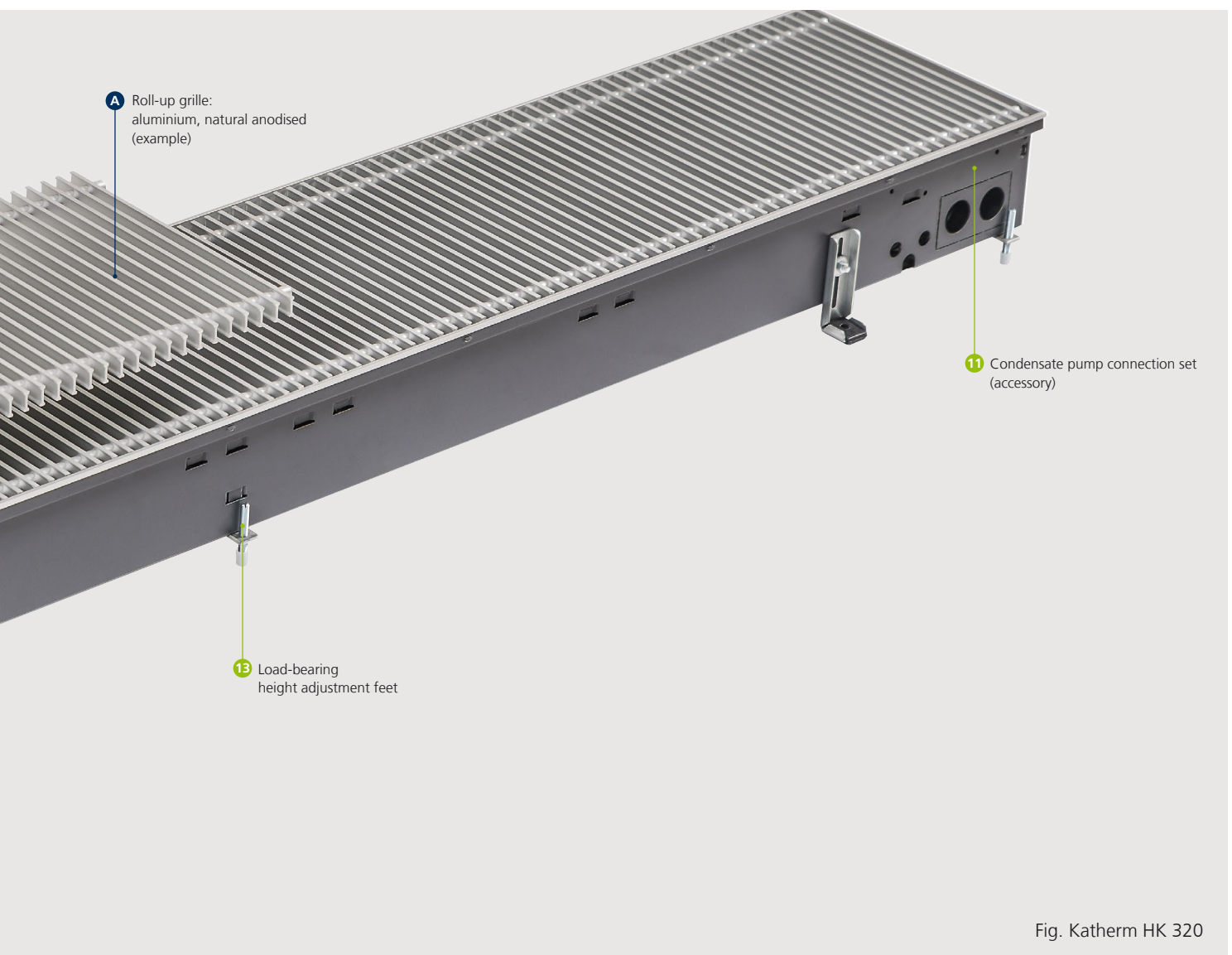

Fig. Katherm HK 320

- 1 Floor trench**
  - ▶ galvanised sheet steel
  - ▶ coated graphite grey on both sides
- 2 Grille frame profile**
  - ▶ to match double T-profile grille
  - ▶ with protective lip on 3 sides
- 3 Junction and control box**
  - ▶ for fast and safe wiring, saves installation time
  - ▶ KaControl or electromechanical control
- 4 Condensate tray**
  - ▶ for the safe discharge of the condensate and simultaneous air guidance
  - ▶ specifically designed for simple cleaning in line with the Hygiene Directive VDI 6022.
  - ▶ can be removed to the room side for complete cleaning
- 5 High-performance convector**
  - ▶ made of copper pipe with aluminium fins
  - ▶ coated graphite-grey
  - ▶ suitable for maximum continuous operating pressure of 10 bar and 120 °C.
  - ▶ Eurokonus connection
  - ▶ for 2-pipe and 4-pipe system
- 6 Segment plate**
  - ▶ acts as a finger guard for the tangential fan, filter frame, airflow baffle, grille seat and reinforcing stay to strengthen the trench
- 7 Filter**
  - ▶ optional accessory
- 8 Highly efficient EC tangential fan**
  - ▶ energy-saving, with flow-optimised impellers, cascaded arrangement as a continuous fan belt (HK 320)
  - ▶ uniform air flow through convector
  - ▶ robust and quiet motor construction
  - ▶ infinitely variable speed control via an external 0-10 V signal
  - ▶ motor monitoring with internal fault processing
- 9 Cover plate**
  - ▶ as visual protection and to protect against dirt
  - ▶ for connecting/return end and intermediate sections
- 10 Height adjustment feet**
  - ▶ for the secure mounting of the trench
  - ▶ with sound insulation
  - ▶ standard
- 11 Condensate pump fitting kit**
  - ▶ available as an accessory to drain condensation, if needed
  - ▶ supplied separately or factory-fitted
- 12 Fixing of tangential fan**
  - ▶ ease of removal of the tangential fan without tool
  - ▶ innovative combined coupling/ball joint system
  - ▶ simultaneous acoustic decoupling
- 13 Load-bearing height adjustment feet**
  - ▶ for height adjustment and support of the trench
- A Aluminium, natural anodised roll-up grille (example)**
  - ▶ grille dimensions 18 x 5 mm
  - ▶ connections made of corrosion-proof steel springs with spacers in a matching colour
  - ▶ free area approx. 70%

## Matching grilles

### Roll-up grilles

**Aluminium**  
Natural anodised

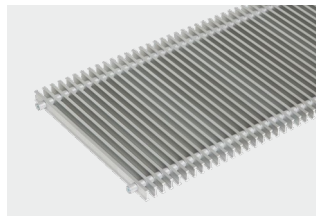

**Aluminium**  
Brass anodised

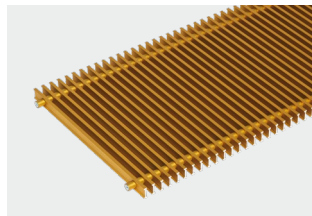

**Aluminium**  
Bronze anodised



**Aluminium**  
Black anodised

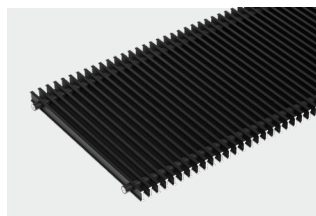

**Aluminium**  
Bronze finish

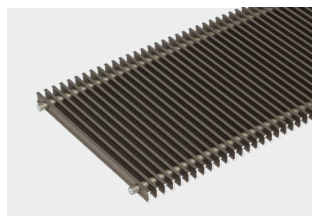

**Aluminium**  
Coated DB 703



**Stainless steel**  
Natural

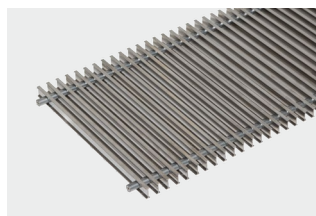

**Stainless steel**  
Polished



**Brass**  
Natural

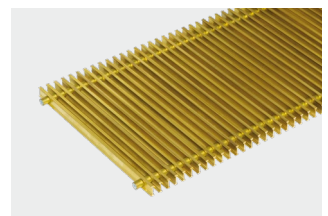



## Linear grilles

**Aluminium**  
Natural anodised

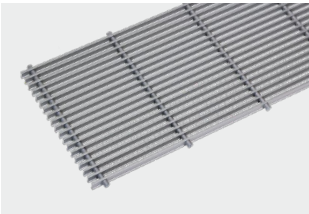

**Aluminium**  
Brass anodised

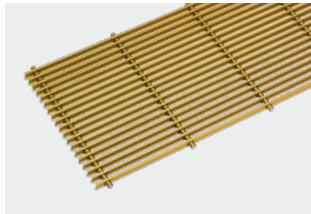

**Aluminium**  
Bronze anodised



**Aluminium**  
Bronze finish

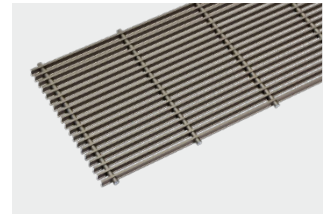

## Profile dimensions

### Double-T profile

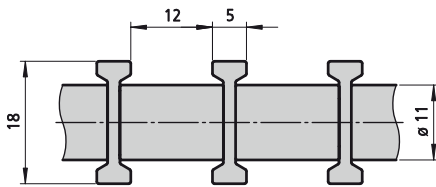

Aluminium, brass

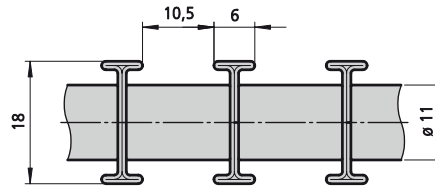

Stainless steel

► For more grilles, please refer to [kampmangroup.com/grilles](http://kampmangroup.com/grilles)

The above grilles are shown using a four-colour printing process and thus do not represent an exact reproduction of the original colour.

## Katherm HK optionally with supply air function

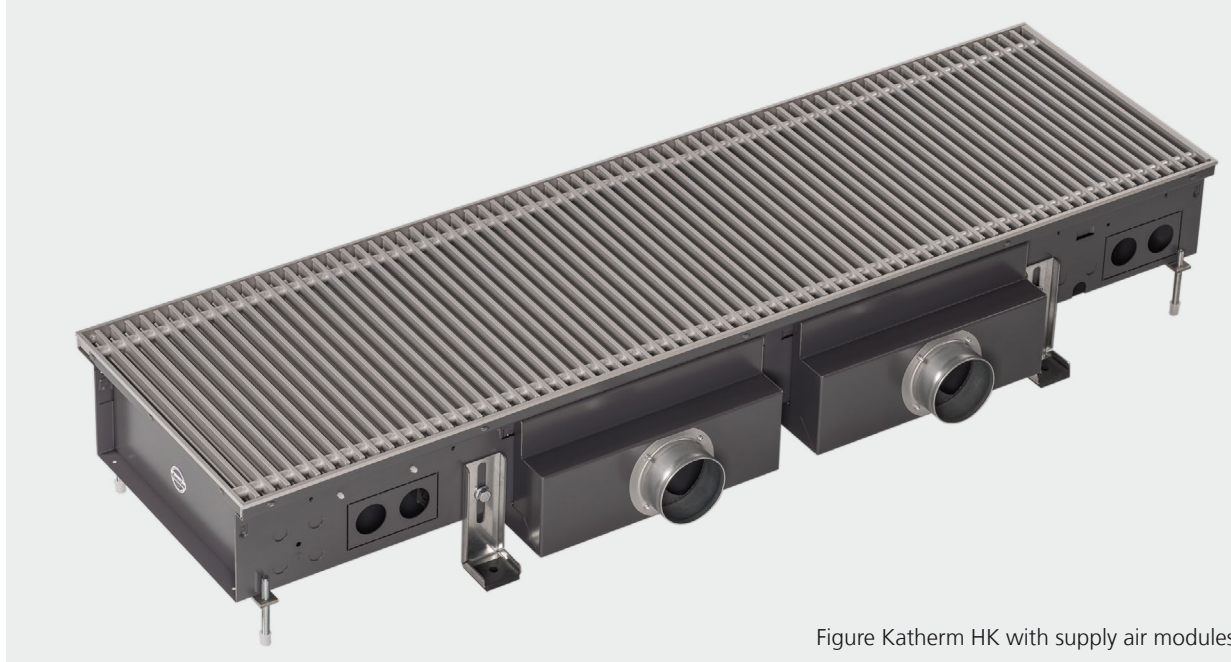

Figure Katherm HK with supply air modules

Katherm HK with supply air function are perfectly suited to supply primary air (fresh air) into a space. Heating, cooling and air supply perfectly combined. There are two models to choose from: primary air entry through supply air modules or through supply air ducts.

### Function of supply air with supply air modules

The conditioned primary air enters through a variable number of supply air modules below the trench unit. It escapes through an outlet slot arranged along the length of the trench unit and mixes with the secondary air heated or cooled by the convector before emerging into the room. Optimum shielding can be provided in front of the glazing with a slow and low-turbulence leaving air velocity. The volume of air supplied can be conveniently adjusted via the variable number of supply air modules per trench and the continuously adjustable slider. Up to 60 m<sup>3</sup>/h of primary air can be supplied per supply air module. High volumetric flow combined with low slider position can lead to noticeable air flow noises (see adjacent diagram).

The designs of Katherm HK with supply air can be adapted on a project-by-project basis. The trench widths are then +20 mm larger compared to the standard widths of Katherm HK models. The trench heights increase by +35 mm (HK 320) or +20 mm (HK 290 and HK 360). More information on request!

### Slider positions<sup>1)</sup>

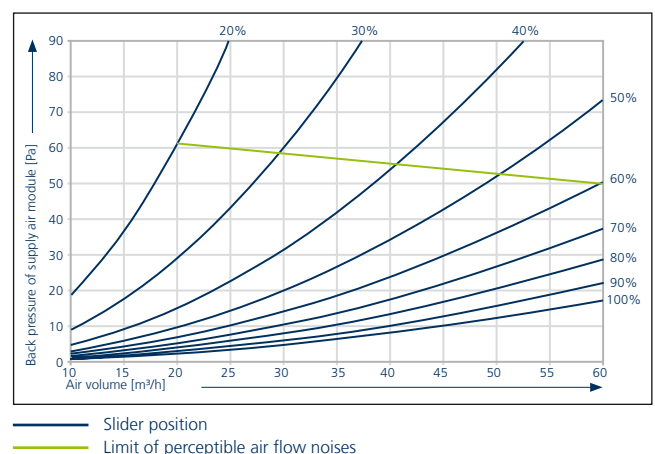

<sup>1)</sup> The slider position corresponds to the percentage of the open cross-sectional area of the supply air inlet.

**Dimensions: Katherm HK with supply air modules**

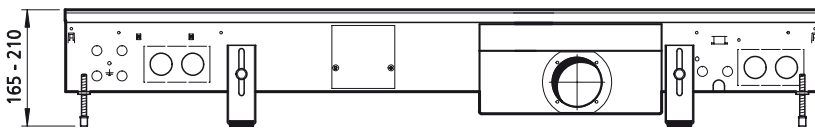

Front view of HK 320 (example shows 1 supply air module)

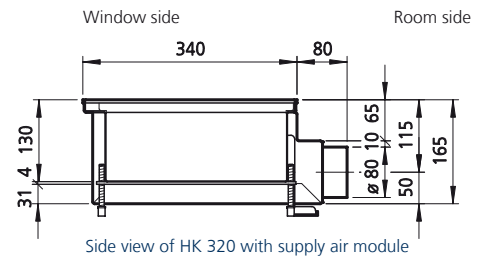

Side view of HK 320 with supply air module

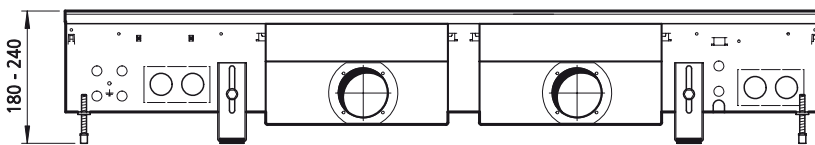

Front view of HK 290 (example shows 2 supply air modules)

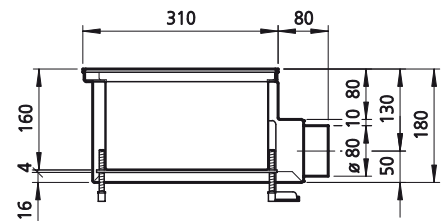

Side view of HK 290 with supply air modules

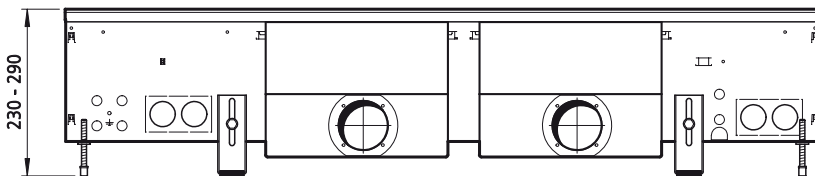

Front view of HK 360 (example shows 2 supply air modules)

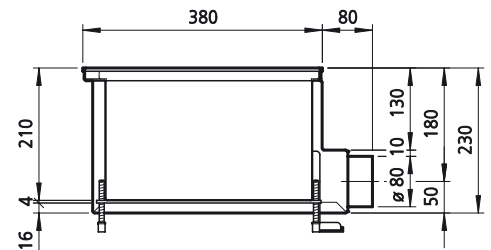

Side view of HK 360 with supply air modules

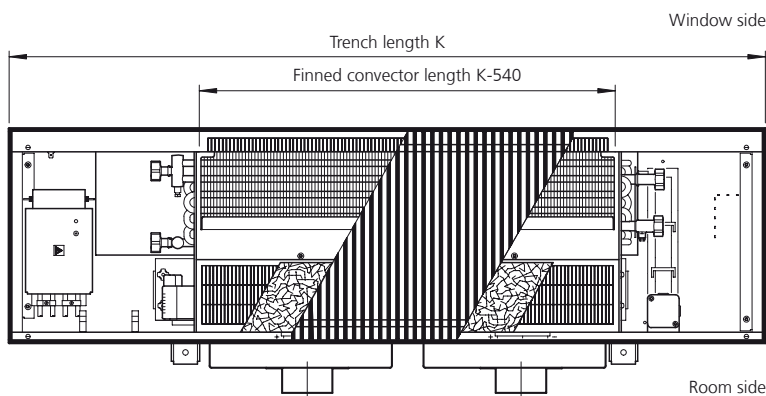

Top view (view without cover panel)

Katherm HK	Unit length [mm]	Max. number of supply air modules
HK 320 HK 290	915 / 950*	1
	1200	2
	1700	3
	2000	4
	2500	5
	3000	6
HK 360	950	1
	1200	2
	1350	2
	1850	3
	2250	4

\* with Katherm HK 290



# Katherm HK – Supply air ducts ZL

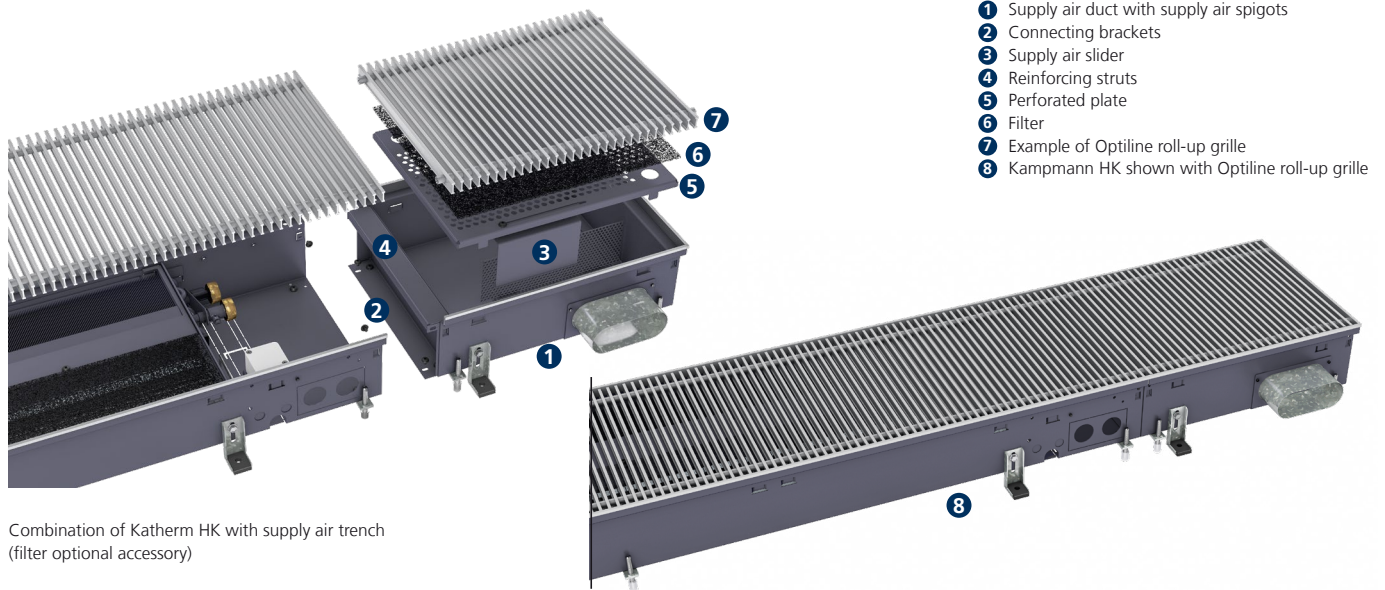

- 1 Supply air duct with supply air spigots
- 2 Connecting brackets
- 3 Supply air slider
- 4 Reinforcing struts
- 5 Perforated plate
- 6 Filter
- 7 Example of Optiline roll-up grille
- 8 Kampmann HK shown with Optiline roll-up grille

Combination of Katherm HK with supply air trench (filter optional accessory)

The Katherm supply air trench ZL is available for all trench heaters (Katherm range). This represents a 400 mm long trench, which can be fitted to all designs of Katherm units. Treated supply air can also be fed into rooms through the Katherm supply air trench ZL. This is achieved with different sizes/designs of spigots for the most diverse trench dimensions. It is possible to regulate the volumetric flow in situ by means of slider elements in the supply air modules.

### Benefits

- ▶ available for trench widths and heights as per the table in the Katherm range
- ▶ supply air feed through the Katherm floor trench
- ▶ low leaving air speeds, hence pleasant levels of comfort
- ▶ low sound development when correctly designed
- ▶ low investment and maintenance costs
- ▶ supply air outlets visually identical to Katherm trench heaters
- ▶ no wear parts / no electrically rotating parts

Trench width [mm]	Trench length [mm]	Trench height [mm]	Supply air spigot [mm]	Max. air volume (noiseless) [m³/h]
320	400	130	oval 51x128	70
290	400	160	DN 80	60
360	400	210	DN 100	85

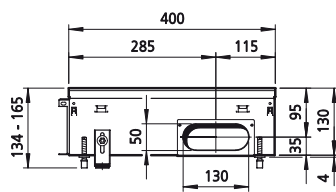

Supply air duct, oval, for Katherm HK 320/130

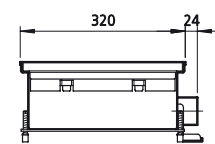

Side view

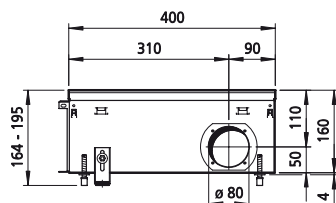

Supply air duct DN 80 for Katherm HK 290/160

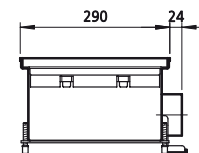

Side view

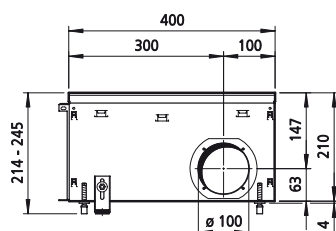

Supply air duct DN 100 for Katherm HK 360/210

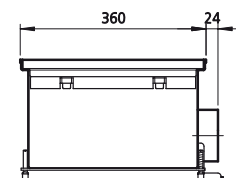

Side view

## Comfort

Comfort also plays a key role in air conditioning. We'll help you to consider this aspect when designing a project using Kampmann trench heaters, at the same time as complying with the current guidelines in DIN EN 15251 (in future DIN EN 16798 Parts 1 and 2) and DIN EN ISO 7730. Essentially the following recommended values can be assumed:

**For heating:**  
 **Supply air outlet air temperature:** 20–26 °C (but not lower than the room temperature)  
 Outlet speed: < 1.5 m/s  
 Distance of supply air trench to the occupied zone: > 0.5 m

**For cooling:**  
 **Supply air outlet air temperature:**  
 < 4K below room temperature  
 Outlet speed: < 1.2 m/s  
 Distance of supply air trench to the occupied zone: > 1 m

### Other parameters

In individual cases, additional parameters, such as room and supply air humidity, as well as leaving air speed, need to be taken into consideration. (See DIN EN ISO 7730)

### Additional information

The supply air trenches Katherm ZL can be used for cooling, heating or isothermic air exchange using preconditioned primary air. A spigot or connection at the front end is also possible with appropriate trench dimensions and sufficient space in the air outlet area (examination on request!).

The upper limit of the air volume in the spigot is calculated from the maximum air speed and cross-section of the spigot. This speed should not exceed 3.0 m/s to avoid additional sound emissions. The resulting air-side pressure losses vary according to the air volume as per the diagram.

## Design diagrams

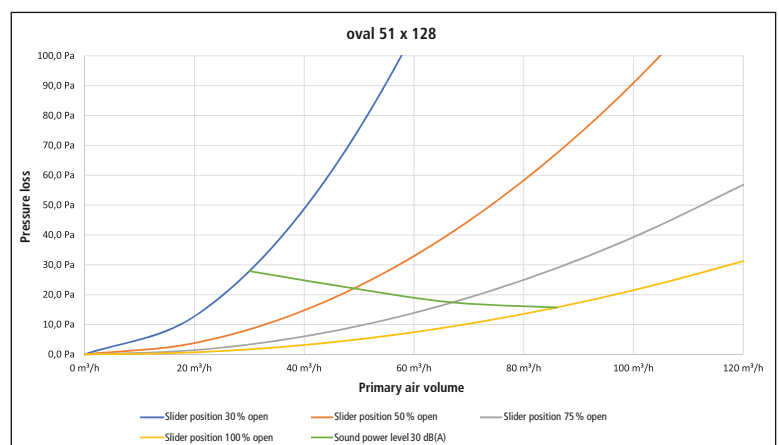
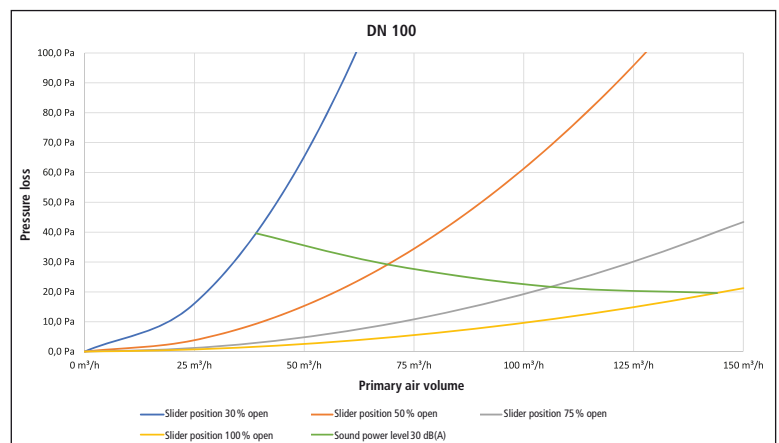
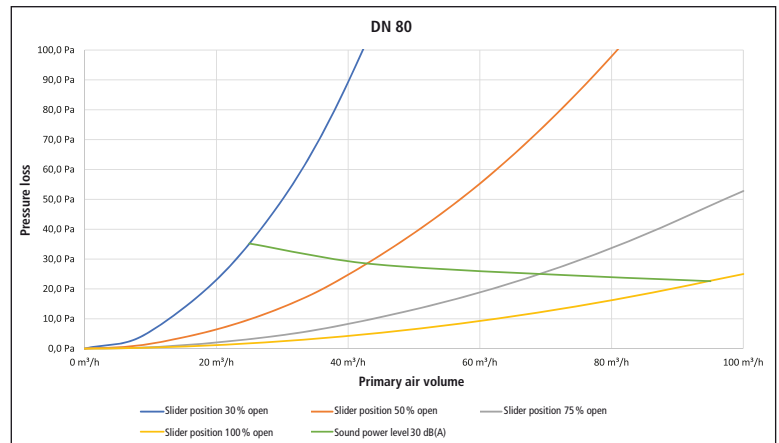

# 02 ▶ Technical data

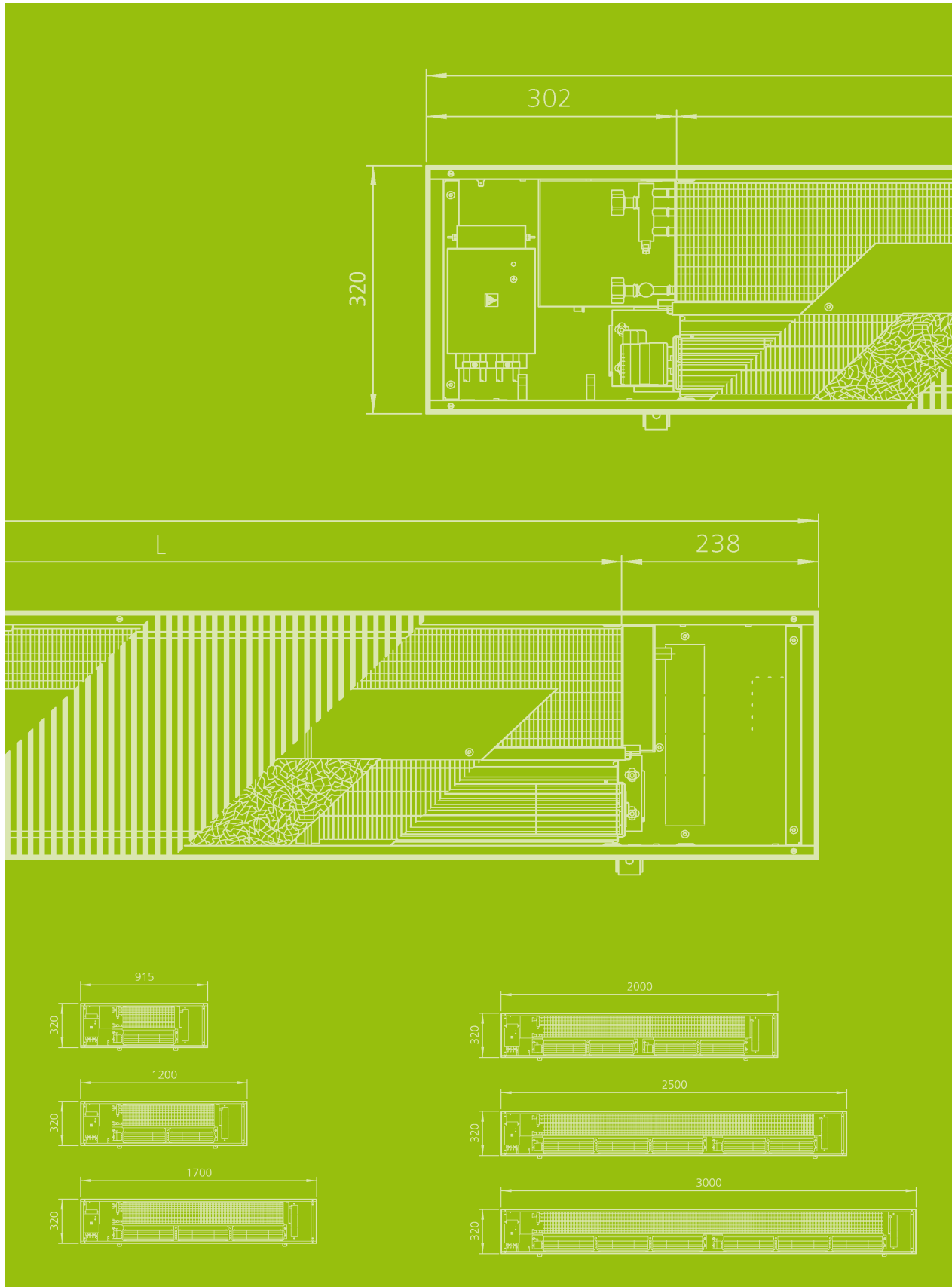



# Advice on measuring conditions

## Heat and cooling outputs

The heat and cooling outputs were measured in accordance with DIN EN 16430 "Fan-assisted heaters, convectors and trench heaters".

- Part 1 "Technical specifications and requirements"
- Part 2 "Test method and evaluation of heat output"
- Part 3 "Test method and evaluation of cooling output"

The standard regulates the performance measurements specifically of trench heaters under normal operating conditions based on DIN EN 442 "Radiators and Convectors".

- Part 1 "Technical specification and requirements"
- Part 2 "Test procedure and performance data"

The specific requirements for cooling mode are taken into account in DIN EN 16430 Part 3. The reference/air temperature is measured in the centre of the test chamber (2 metres from the external wall) at a height of 0.75 metres. This reference / air temperature is not to be confused with inlet air temperature. This may differ significantly between the short circuit that cannot be avoided between the air outlet and air intake.

The heat loads are introduced into the test cabin by 10 output-controlled dummies (see photo) so that they cannot or can only reproducibly influence the outputs and functions.

Katherm HK have been developed and designed to be optimised in terms of short-circuiting. The likelihood of

short-circuiting has been minimised as far as technically possible.

## Acoustics

Katherm HK are very often used in acoustically sensitive areas. Accordingly, Katherm HK have been optimised in terms of noise levels. The sound power level is measured in accordance with DIN EN ISO 3744. (Determination of the sound power and sound energy levels of sources of sound from sound pressure measurements – precision 2 class of enveloping measurement surface for an essentially free sound field over a reflective plane) in a semi-low reflective acoustic measuring chamber.



Heat and cooling output test cabin

## Comparison of air flow profiles

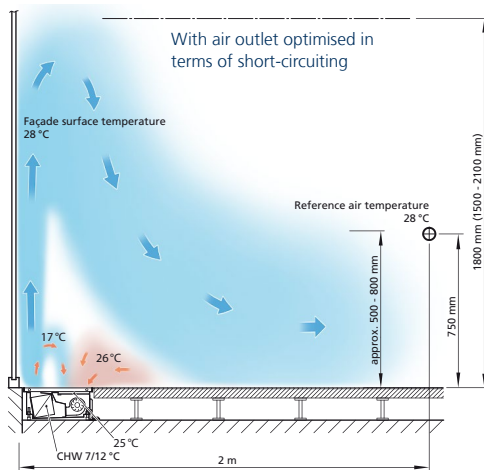
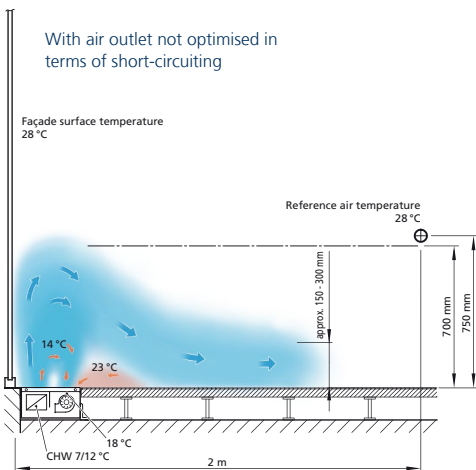

# Katherm HK 320

## 2-pipe, trench height 130 mm

Technical drawings (all dimensions in mm)

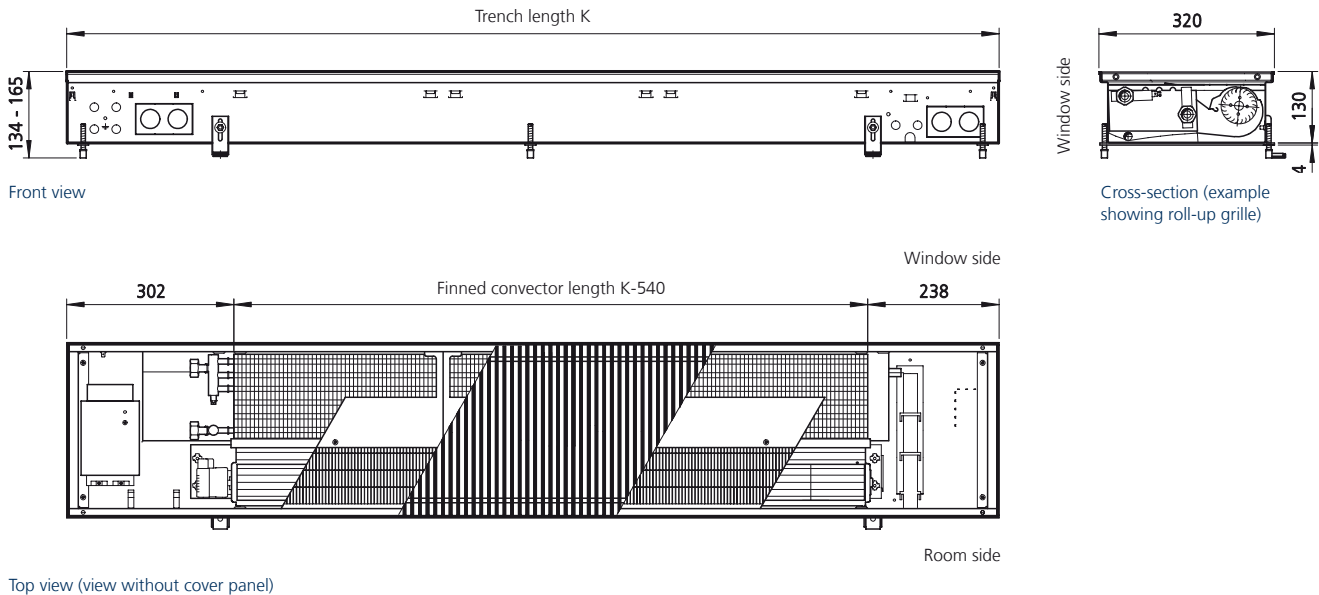

### Specifications

#### Connections:

Eurokonus, one-sided  
Connecting side for heating/cooling on left

#### Condensate connection:

15 mm spigots

Trench length	Finned convector length	Fan impellers	Fan motors
[mm]	[mm]	[Quantity]	[Quantity]
915	375	1	1
1200	660	2	1
1700	1160	3	1
2000	1460	4	2
2500	1960	5	2
3000	2460	6	2

### Water resistance

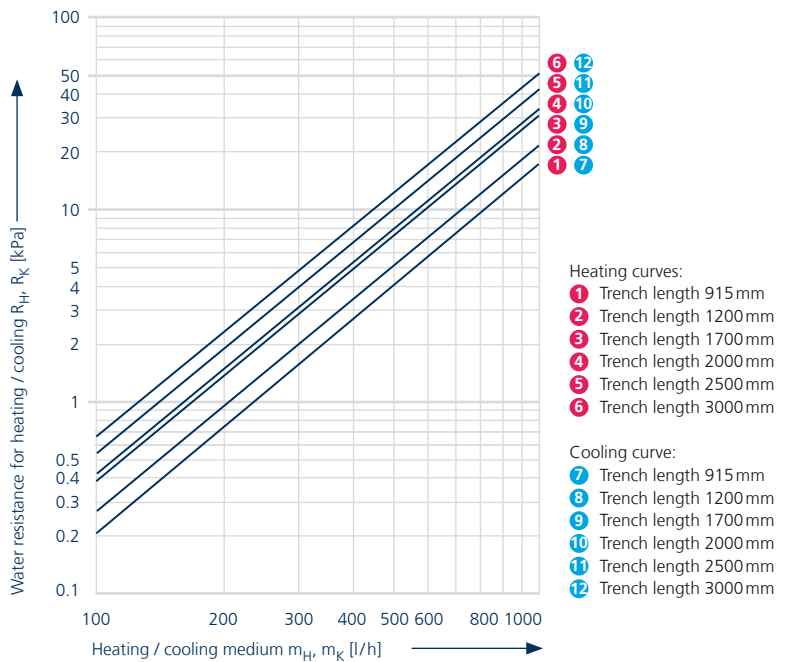

Make use of our online calculation programs to calculate your heat and cooling outputs and heating and cooling flow rates with a couple of clicks!

► [kampmanngroup.com//katherm-hk](http://kampmanngroup.com//katherm-hk)

**Outputs**



Operating level	at speed setting	Heat outputs <sup>1)</sup>				Cooling outputs <sup>2)</sup>						Power consumption <sup>3)</sup>	Current consumption	Specific fan power	Air volume <sup>6)</sup>	Sound pressure level <sup>4)</sup>	Sound power level
		at LPHW 75 / 65 °C		at LPHW 82 / 71 °C		at CHW 16 / 18 °C			at CHW 7 / 12 °C								
		Q <sub>H</sub> [W]	t <sub>L2</sub> [°C]	Q <sub>H</sub> [W]	t <sub>L2</sub> [°C]	Q <sub>K</sub> [W]	Q <sub>S</sub> [W]	t <sub>L2</sub> [°C]	Q <sub>K</sub> [W]	Q <sub>S</sub> [W]	t <sub>L2</sub> [°C]						
<b>Trench length 915 mm</b>																	
<b>Boost stage</b>		2101	56.9	2388	61.9	356	356	20.7	620	533	17.6	7.9	82	0.167	47	39	47
<b>Design stages</b>	80	1744	57.2	1977	62.2	292	292	20.8	513	435	17.7	6.5	67	0.167	39	33	41
	60	1484	62.2	1689	68.0	216	216	20.9	389	322	17.9	5.6	58	0.192	29	27	35
	40	1101	63.8	1252	69.8	152	152	21.0	282	224	18.1	5.0	52	0.240	21	<20 <sup>5)</sup>	<28 <sup>5)</sup>
<b>Minimum stage</b>	20	706	66.8	803	73.3	87	87	21.2	175	127	18.6	4.7	49	0.376	13	<20 <sup>5)</sup>	<28 <sup>5)</sup>
<b>Trench length 1200 mm</b>																	
<b>Boost stage</b>		3627	58.0	4110	63.0	630	630	20.4	1210	958	17.0	11.4	118	0.144	79	41	49
<b>Design stages</b>	80	3125	60.6	3559	66.2	504	504	20.5	975	764	17.1	8.4	86	0.131	64	36	44
	60	2488	61.3	2816	66.7	389	389	20.5	761	588	17.2	6.5	67	0.130	50	29	37
	40	1814	61.6	2036	66.8	275	275	20.7	547	412	17.5	5.5	57	0.152	36	20	28
<b>Minimum stage</b>	20	1102	61.1	1218	65.5	160	160	21.0	333	236	18.2	4.9	51	0.221	22	<20 <sup>5)</sup>	<28 <sup>5)</sup>
<b>Trench length 1700 mm</b>																	
<b>Boost stage</b>		6043	59.2	6839	64.4	1043	1043	20.2	2106	1591	16.7	16.4	169	0.128	128	41	49
<b>Design stages</b>	80	5624	60.5	6365	65.8	936	936	20.3	1894	1425	16.7	13.3	137	0.115	115	38	46
	60	4525	61.6	5116	67.0	721	721	20.4	1470	1095	16.9	9.0	93	0.100	90	31	39
	40	3317	63.0	3747	68.6	494	494	20.6	1023	747	17.3	6.5	67	0.102	64	23	31
<b>Minimum stage</b>	20	2149	65.8	2428	71.8	279	279	21.1	599	417	18.1	5.3	55	0.136	39	<20 <sup>5)</sup>	<28 <sup>5)</sup>
<b>Trench length 2000 mm</b>																	
<b>Boost stage</b>	100	7573	59.7	8564	64.8	1326	1326	20.1	2724	2038	16.3	22.9	237	0.145	158	44	52
<b>Design stages</b>	80	6380	61.0	7210	66.3	1070	1070	20.1	2205	1640	16.5	16.7	173	0.129	129	39	47
	60	5137	62.6	5805	68.1	813	813	20.3	1686	1242	16.7	13.0	135	0.130	100	32	40
	40	3842	65.0	4348	70.9	557	557	20.5	1168	844	17.1	11.0	114	0.155	71	23	31
<b>Minimum stage</b>	20	2321	64.7	2611	70.3	312	312	21.0	674	465	18.1	9.8	102	0.228	43	<20 <sup>5)</sup>	<28 <sup>5)</sup>
<b>Trench length 2500 mm</b>																	
<b>Boost stage</b>	100	10103	60.2	11422	65.5	1749	1749	20.0	3634	2685	16.3	27.8	288	0.133	208	44	52
<b>Design stages</b>	80	9019	61.4	10198	66.8	1503	1503	20.1	3131	2304	16.4	21.6	224	0.120	181	40	48
	60	7175	62.4	8103	67.9	1146	1146	20.2	2401	1751	16.6	15.5	160	0.110	140	33	41
	40	5281	63.8	5958	69.4	789	789	20.5	1672	1199	17.1	12.0	124	0.120	100	25	33
<b>Minimum stage</b>	20	3336	66.3	3762	72.2	432	432	21.0	942	646	18.0	10.2	106	0.171	60	<20 <sup>5)</sup>	<28 <sup>5)</sup>
<b>Trench length 3000 mm</b>																	
<b>Boost stage</b>	100	12553	60.5	14191	65.8	2159	2159	20.0	4515	3313	16.3	32.7	339	0.127	257	44	52
<b>Design stages</b>	80	11576	61.4	13088	66.8	1936	1936	20.1	4057	2969	16.4	26.5	275	0.114	232	41	49
	60	9158	62.4	10341	67.9	1466	1466	20.2	3091	2243	16.6	17.9	185	0.100	179	34	42
	40	6744	63.8	7609	69.4	1009	1009	20.5	2149	1535	17.0	12.9	134	0.101	128	26	34
<b>Minimum stage</b>	20	4266	66.3	4811	72.2	551	551	21.0	1208	828	18.0	10.6	110	0.139	76	<20 <sup>5)</sup>	<28 <sup>5)</sup>

Q<sub>H</sub> [W] = Heat output; Q<sub>K</sub> [W] = Cooling output, total; Q<sub>S</sub> [W] = Cooling output, sensitive; t<sub>L2</sub> [°C] = Leaving air temperature

<sup>1)</sup> at room temperature t<sub>L</sub> = 20 °C

<sup>2)</sup> at room temperature t<sub>L</sub> = 27 °C, rel. humidity 48%

<sup>3)</sup> Add an additional power consumption of 1W per valve drive type 146906.

<sup>4)</sup> The sound pressure levels were calculated with an assumed room insulation of 8dB(A). This corresponds to a clearance of 2 m, a room volume of 100m<sup>3</sup> and a reverberation time of 0.5 s (according to VDI 2081).

<sup>5)</sup> Sound pressure level < 20 dB (A) and sound power level < 28 dB (A) outside the usual measuring and audible range.

<sup>6)</sup> Values rounded up within measurement tolerances.



# Katherm HK 320

## 4-pipe, trench height 130 mm

Technical drawings (all dimensions in mm)

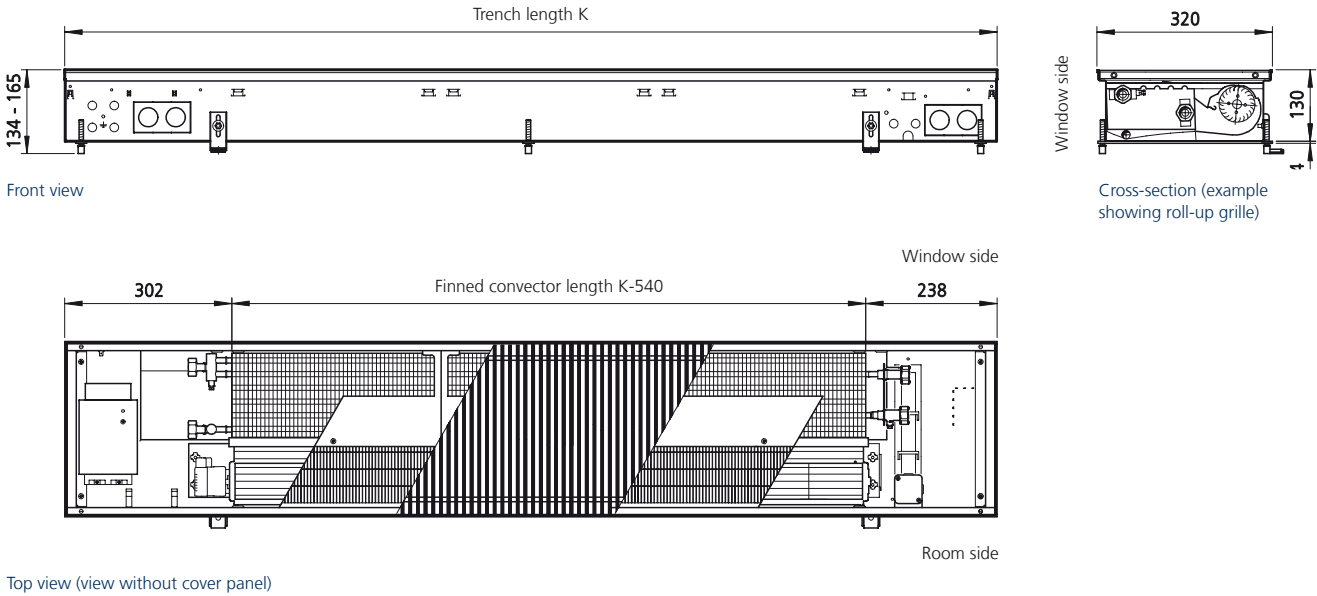

### Specifications

**Connections:**

Eurokonus, opposite end  
Cooling connection on left  
Heating connection on right

**Condensate connection:**

15 mm spigots

Trench length	Finned convector length	Fan impellers	Fan motors
[mm]	[mm]	[Quantity]	[Quantity]
915	375	1	1
1200	660	2	1
1700	1160	3	1
2000	1460	4	2
2500	1960	5	2
3000	2460	6	2

### Water resistance

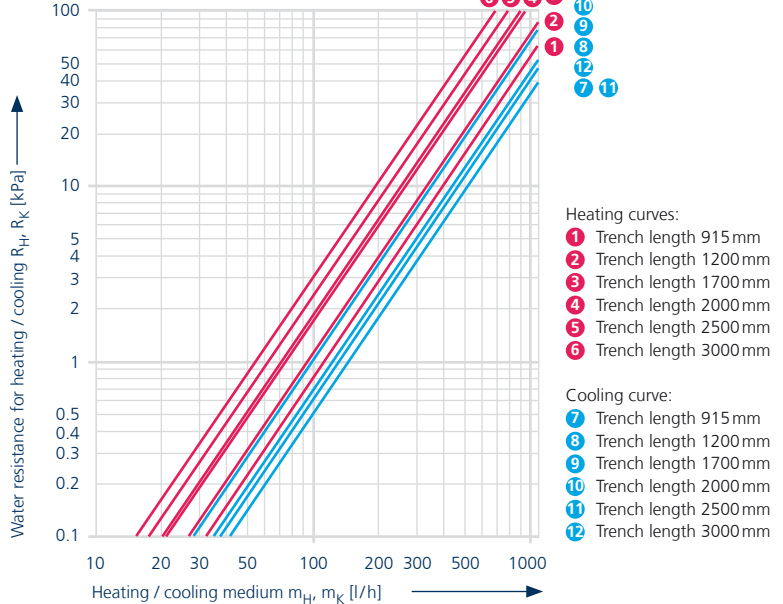

Make use of our online calculation programs to calculate your heat and cooling outputs and heating and cooling flow rates with a couple of clicks!

► [kampmanngroup.com/katherm-hk](http://kampmanngroup.com/katherm-hk)

Outputs



Operating level	at speed setting	Heat outputs <sup>1)</sup>				Cooling outputs <sup>2)</sup>						Power consumption <sup>3)</sup>	Current consumption	Specific fan power	Air volume <sup>6)</sup>	Sound pressure level <sup>4)</sup>	Sound power level
		at LPHW 75 / 65 °C		at LPHW 82 / 71 °C		at CHW 16 / 18 °C			at CHW 7 / 12 °C								
		Q <sub>H</sub> [W]	t <sub>L2</sub> [°C]	Q <sub>H</sub> [W]	t <sub>L2</sub> [°C]	Q <sub>K</sub> [W]	Q <sub>S</sub> [W]	t <sub>L2</sub> [°C]	Q <sub>K</sub> [W]	Q <sub>S</sub> [W]	t <sub>L2</sub> [°C]						
<b>Trench length 915 mm</b>																	
Boost stage	100	1220	41.4	1397	44.5	337	337	21.1	614	534	17.6	7.9	82	0.167	47	39	47
Design stages	80	1053	42.4	1203	45.7	277	277	21.1	508	435	17.7	6.5	67	0.167	39	33	41
	60	919	46.1	1051	49.9	206	206	21.1	384	320	17.9	5.6	58	0.192	29	27	35
	40	735	49.3	842	53.5	146	146	21.2	279	222	18.2	5.0	52	0.240	21	<20 <sup>5)</sup>	<28 <sup>5)</sup>
Minimum stage	20	544	56.1	625	61.5	85	85	21.4	173	123	18.8	4.7	49	0.376	13	<20 <sup>5)</sup>	<28 <sup>5)</sup>
<b>Trench length 1200 mm</b>																	
Boost stage	100	2185	42.9	2486	46.0	620	620	20.5	1176	944	17.1	11.4	118	0.144	79	41	49
Design stages	80	1956	45.4	2226	48.9	497	497	20.5	950	755	17.2	8.4	86	0.131	64	36	44
	60	1643	47.2	1868	51.0	385	385	20.6	745	582	17.3	6.5	67	0.130	50	29	37
	40	1309	50.1	1488	54.2	273	273	20.7	541	410	17.6	5.5	57	0.152	36	20	28
Minimum stage	20	954	55.6	1088	60.6	161	161	21.0	336	237	18.1	4.9	51	0.221	22	<20 <sup>5)</sup>	<28 <sup>5)</sup>
<b>Trench length 1700 mm</b>																	
Boost stage	100	3785	44.6	4293	47.9	1027	1027	20.3	2043	1566	16.8	16.4	169	0.128	128	41	49
Design stages	80	3591	45.8	4076	49.3	922	922	20.4	1840	1405	16.9	13.3	137	0.115	115	38	46
	60	3038	47.9	3443	51.6	712	712	20.5	1435	1082	17.1	9.0	93	0.100	90	31	39
	40	2404	51.2	2723	55.3	490	490	20.6	1007	741	17.4	6.5	67	0.102	64	23	31
Minimum stage	20	1766	57.6	2005	62.7	280	280	21.0	602	418	18.1	5.3	55	0.136	39	<20 <sup>5)</sup>	<28 <sup>5)</sup>
<b>Trench length 2000 mm</b>																	
Boost stage	100	4884	45.6	5536	49.0	1307	1307	20.2	2649	2006	16.5	22.9	237	0.145	158	44	52
Design stages	80	4182	46.8	4740	50.4	1055	1055	20.2	2153	1617	16.6	16.7	173	0.129	129	39	47
	60	3480	48.9	3944	52.7	804	804	20.3	1656	1228	16.8	13.0	135	0.130	100	32	40
	40	2778	52.5	3148	56.8	553	553	20.5	1160	838	17.2	11.0	114	0.155	71	23	31
Minimum stage	20	2110	60.6	2389	66.0	314	314	21.0	687	467	18.0	9.8	102	0.228	43	<20 <sup>5)</sup>	<28 <sup>5)</sup>
<b>Trench length 2500 mm</b>																	
Boost stage	100	6415	45.5	7268	48.9	1722	1722	20.1	3524	2642	16.5	27.8	288	0.133	208	44	52
Design stages	80	5924	47.2	6715	50.8	1481	1481	20.2	3042	2269	16.6	21.6	224	0.120	181	40	48
	60	4964	49.3	5617	53.2	1132	1132	20.3	2344	1729	16.8	15.5	160	0.110	140	33	41
	40	3930	52.6	4444	56.9	782	782	20.5	1646	1189	17.1	12.0	124	0.120	100	25	33
Minimum stage	20	2822	59.2	3198	64.4	433	433	21.0	948	649	18.0	10.2	106	0.171	60	<20 <sup>5)</sup>	<28 <sup>5)</sup>
<b>Trench length 3000 mm</b>																	
Boost stage	100	8004	45.8	9062	49.2	2124	2124	20.1	4379	3260	16.5	32.7	339	0.127	257	44	52
Design stages	80	7588	47.1	8596	50.7	1906	1906	20.2	3941	2923	16.5	26.5	275	0.114	232	41	49
	60	6333	49.3	7160	53.1	1447	1447	20.3	3015	2213	16.8	17.9	185	0.100	179	34	42
	40	5020	52.6	5672	56.8	1000	1000	20.5	2114	1522	17.1	12.9	134	0.101	128	26	34
Minimum stage	20	3611	59.2	4089	64.4	552	552	21.0	1214	830	18.0	10.6	110	0.139	76	<20 <sup>5)</sup>	<28 <sup>5)</sup>

Q<sub>H</sub> [W] = Heat output; Q<sub>K</sub> [W] = Cooling output, total; Q<sub>S</sub> [W] = Cooling output, sensitive; t<sub>L2</sub> [°C] = Leaving air temperature

<sup>1)</sup> at room temperature t<sub>L</sub> = 20 °C

<sup>2)</sup> at room temperature t<sub>L</sub> = 27 °C, rel. humidity 48%

<sup>3)</sup> Add an additional power consumption of 1W per valve drive type 146906.

<sup>4)</sup> The sound pressure levels were calculated with an assumed room insulation of 8dB(A). This corresponds to a clearance of 2 m, a room volume of 100m<sup>3</sup> and a reverberation time of 0.5 s (according to VDI 2081).

<sup>5)</sup> Sound pressure level < 20 dB (A) and sound power level < 28 dB (A) outside the usual measuring and audible range.

<sup>6)</sup> Values rounded up within measurement tolerances.



# Katherm HK 290

## 2-pipe, trench height 160 mm

Technical drawings (all dimensions in mm)

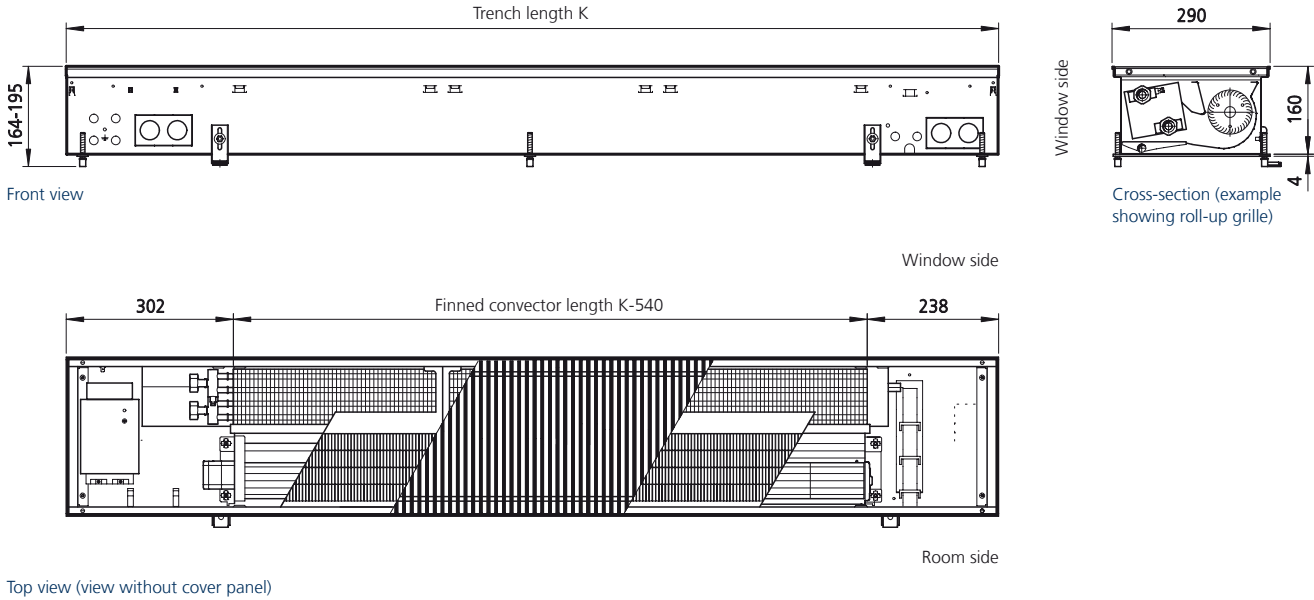

### Specifications

#### Connections:

Eurokonus, one-sided  
Connecting side for heating/cooling on left

#### Condensate connection:

15 mm spigots

Trench length	Finned convector length	Fan impellers	Fan motors
[mm]	[mm]	[Quantity]	[Quantity]
950	410	1	1
1200	660	1	1
1700	1160	2	2
2000	1460	2	2
2500	1960	3	3
3000	2460	3	3

### Water resistance

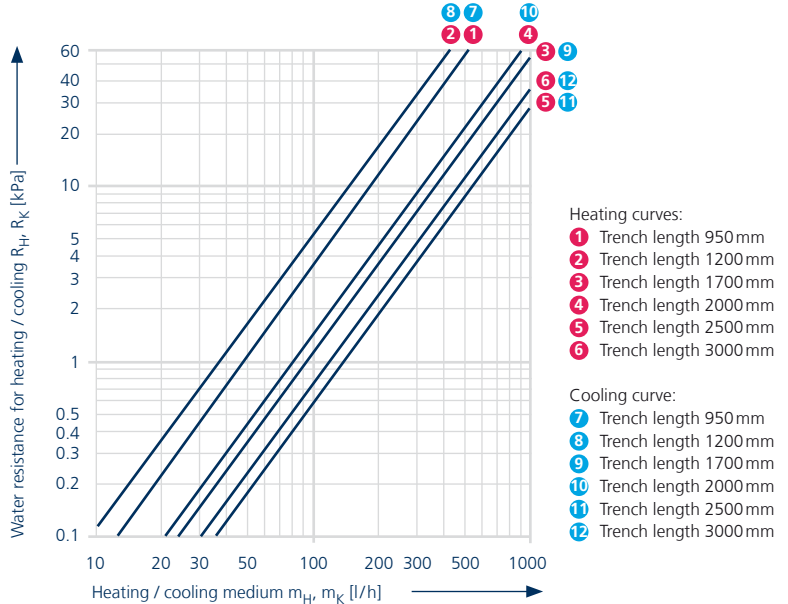

Make use of our online calculation programs to calculate your heat and cooling outputs and heating and cooling flow rates with a couple of clicks!

► [kampmanngroup.com//katherm-hk](http://kampmanngroup.com//katherm-hk)

Outputs



Operating level	at speed setting	Heat outputs <sup>1)</sup>				Cooling outputs <sup>2)</sup>						Power consumption <sup>3)</sup>	Current consumption	Specific fan power	Air volume <sup>6)</sup>	Sound pressure level <sup>4)</sup>	Sound power level
		at LPHW 75 / 65°C		at LPHW 82 / 71°C		at CHW 16 / 18°C			at CHW 7 / 12°C								
		Q <sub>H</sub> [W]	t <sub>L</sub> [°C]	Q <sub>H</sub> [W]	t <sub>L</sub> [°C]	Q <sub>K</sub> [W]	Q <sub>S</sub> [W]	t <sub>L</sub> [°C]	Q <sub>K</sub> [W]	Q <sub>S</sub> [W]	t <sub>L</sub> [°C]						
<b>Trench length 950 mm</b>																	
Boost stage	100	2811	58.4	3177	63.7	534	534	19.7	982	765	13.5	8.4	74	0.137	61	39	47
Design stages	80	2267	59.8	2563	65.3	398	398	19.2	738	570	13.2	4.6	44	0.095	49	33	41
	60	1660	61.9	1876	67.6	259	259	18.5	487	371	12.7	2.5	26	0.072	35	24	32
	40	1089	64.9	1231	70.9	145	145	17.5	278	208	12.0	1.6	19	0.077	21	<20 <sup>5)</sup>	<28 <sup>5)</sup>
Minimum stage	20	673	68.5	760	74.8	75	75	16.5	146	108	11.3	1.3	18	0.117	11	<20 <sup>5)</sup>	<28 <sup>5)</sup>
<b>Trench length 1200 mm</b>																	
Boost stage	100	4752	58.5	5371	63.9	903	903	19.7	1635	1294	13.5	16.1	143	0.159	101	42	50
Design stages	80	3833	59.9	4332	65.4	672	672	19.2	1228	963	13.2	8.8	84	0.109	81	35	43
	60	2805	62.0	3171	67.7	438	438	18.5	811	628	12.7	4.8	50	0.084	57	26	34
	40	1841	65.0	2081	71.0	246	246	17.5	463	352	12.0	3.1	37	0.089	35	<20 <sup>5)</sup>	<28 <sup>5)</sup>
Minimum stage	20	1137	68.6	1285	75.0	127	127	16.5	244	182	11.3	2.6	34	0.156	17	<20 <sup>5)</sup>	<28 <sup>5)</sup>
<b>Trench length 1700 mm</b>																	
Boost stage	100	7562	58.7	8548	64.0	1437	1437	19.7	2567	2059	13.5	24.4	218	0.150	163	44	52
Design stages	80	6100	60.1	6895	65.5	1070	1070	19.2	1928	1533	13.2	13.4	127	0.104	129	37	45
	60	4465	62.2	5047	67.9	698	698	18.4	1273	999	12.7	7.3	76	0.081	90	28	36
	40	2930	65.1	3311	71.1	391	391	17.5	727	561	12.0	4.8	56	0.089	54	<20 <sup>5)</sup>	<28 <sup>5)</sup>
Minimum stage	20	1810	68.7	2045	75.1	202	202	16.5	383	290	11.3	3.9	51	0.140	28	<20 <sup>5)</sup>	<28 <sup>5)</sup>
<b>Trench length 2000 mm</b>																	
Boost stage	100	9905	58.7	11195	64.1	1882	1882	19.7	3335	2696	13.5	34.7	309	0.163	213	45	53
Design stages	80	7989	60.1	9030	65.6	1402	1402	19.2	2505	2008	13.1	19.1	180	0.114	168	38	46
	60	5848	62.2	6610	67.9	914	914	18.4	1654	1309	12.7	10.4	108	0.088	118	29	37
	40	3837	65.2	4337	71.2	513	513	17.5	944	734	12.0	6.8	80	0.096	71	20	28
Minimum stage	20	2370	68.8	2679	75.2	265	265	16.5	497	379	11.3	5.6	73	0.161	35	<20 <sup>5)</sup>	<28 <sup>5)</sup>
<b>Trench length 2500 mm</b>																	
Boost stage	100	12648	58.8	14296	64.2	2404	2404	19.7	4228	3443	13.5	43.1	383	0.159	271	46	54
Design stages	80	10203	60.2	11532	65.7	1790	1790	19.2	3176	2564	13.1	23.7	224	0.110	215	39	47
	60	7468	62.3	8441	68.0	1167	1167	18.4	2097	1672	12.7	12.9	134	0.085	151	30	38
	40	4900	65.3	5538	71.3	655	655	17.5	1197	938	12.0	8.4	99	0.093	90	21	29
Minimum stage	20	3027	68.9	3421	75.2	338	338	16.5	630	484	11.3	6.9	90	0.155	44	<20 <sup>5)</sup>	<28 <sup>5)</sup>
<b>Trench length 3000 mm</b>																	
Boost stage	100	16865	58.9	19062	64.2	3205	3205	19.7	5589	4591	13.5	60.0	534	0.167	360	47	55
Design stages	80	13604	60.3	15376	65.8	2387	2387	19.2	4199	3419	13.1	33.0	312	0.115	286	41	49
	60	9957	62.4	11254	68.1	1556	1556	18.4	2772	2229	12.7	18.0	186	0.089	201	31	39
	40	6533	65.3	7385	71.3	873	873	17.5	1582	1250	12.0	11.7	138	0.097	121	22	30
Minimum stage	20	4036	68.9	4561	75.3	451	451	16.5	833	646	11.3	9.6	126	0.161	60	<20 <sup>5)</sup>	<28 <sup>5)</sup>

Q<sub>H</sub> [W] = Heat output; Q<sub>K</sub> [W] = Cooling output, total; Q<sub>S</sub> [W] = Cooling output, sensitive; t<sub>L</sub> [°C] = Leaving air temperature

<sup>1)</sup> at room temperature t<sub>L</sub> = 20°C

<sup>2)</sup> at room temperature t<sub>L</sub> = 27°C, rel. humidity 48%

<sup>3)</sup> Add an additional power consumption of 1W per valve drive type 146906;

<sup>4)</sup> The sound pressure levels were calculated with an assumed room insulation of 8dB(A). This corresponds to a clearance of 2 m, a room volume of 100m<sup>3</sup> and a reverberation time of 0.5 s (according to VDI 2081).

<sup>5)</sup> Sound pressure level < 20 dB (A) and sound power level < 28 dB (A) outside the usual measuring and audible range.

<sup>6)</sup> Values rounded up within measurement tolerances.

# Katherm HK 290

## 4-pipe, trench height 160 mm

Technical drawings (all dimensions in mm)

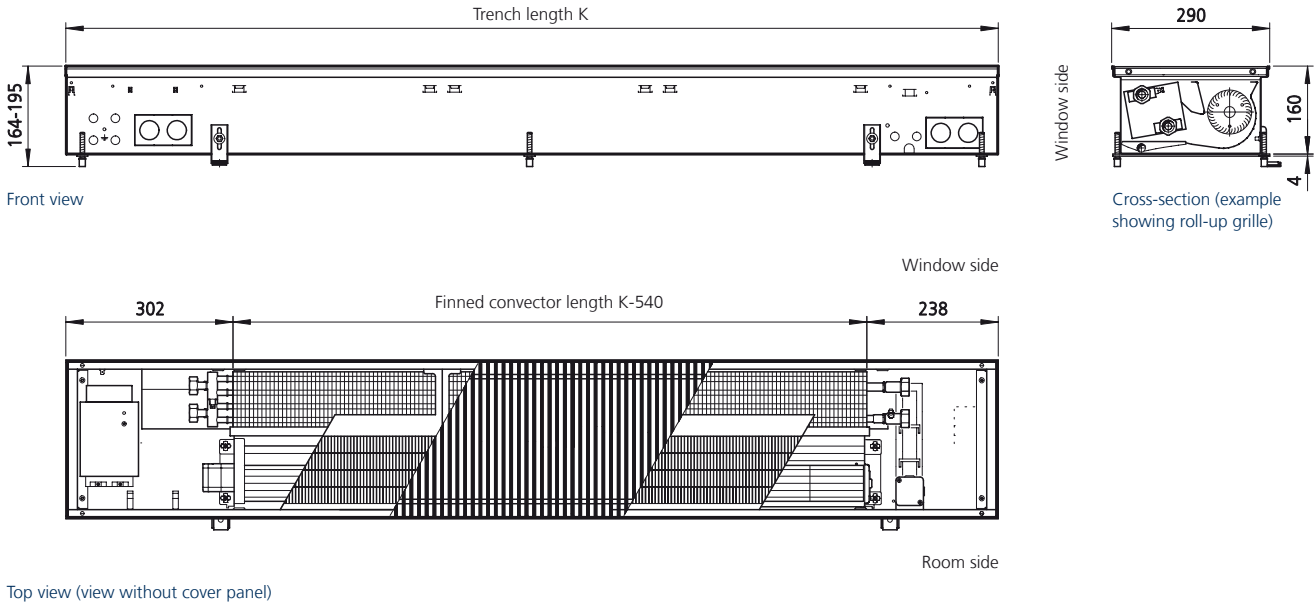

### Specifications

#### Connections:

Eurokonus, opposite end  
 Connection side for cooling on left  
 Heating connection on right

#### Condensate connection:

15 mm spigots

Trench length	Finned convector length	Fan impellers	Fan motors
[mm]	[mm]	[Quantity]	[Quantity]
950	410	1	1
1200	660	1	1
1700	1160	2	2
2000	1460	2	2
2500	1960	3	3
3000	2460	3	3

### Water resistance

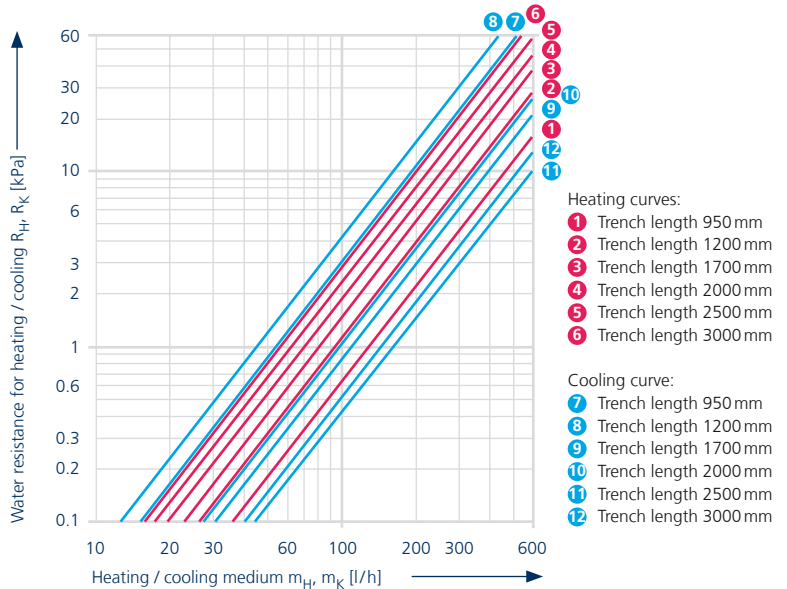

Make use of our online calculation programs to calculate your heat and cooling outputs and heating and cooling flow rates with a couple of clicks!

► [kampmanngroup.com/katherm-hk](http://kampmanngroup.com/katherm-hk)



Outputs



Operating level	at speed setting	Heat outputs <sup>1)</sup>				Cooling outputs <sup>2)</sup>						Power consumption <sup>3)</sup>	Current consumption	Specific fan power	Air volume <sup>6)</sup>	Sound pressure level <sup>4)</sup>	Sound power level
		at LPHW 75 / 65°C		at LPHW 82 / 71°C		at CHW 16 / 18°C			at CHW 7 / 12°C								
		Q <sub>H</sub> [W]	t <sub>L</sub> [°C]	Q <sub>H</sub> [W]	t <sub>L</sub> [°C]	Q <sub>K</sub> [W]	Q <sub>S</sub> [W]	t <sub>L</sub> [°C]	Q <sub>K</sub> [W]	Q <sub>S</sub> [W]	t <sub>L</sub> [°C]						
<b>Trench length 950 mm</b>																	
Boost stage	100	1586	40.5	1791	44.0	495	495	20.4	954	743	14.5	8.4	0.137	61	220	39	47
Design stages	80	1358	42.6	1533	46.4	370	370	19.7	720	556	14.1	4.6	0.095	49	175	33	41
	60	1084	46.0	1224	50.3	243	243	18.8	479	365	13.4	2.5	0.072	35	125	24	32
	40	799	51.4	902	56.4	138	138	17.7	276	207	12.6	1.6	0.077	21	75	<20 <sup>5)</sup>	<28 <sup>5)</sup>
Minimum stage	20	564	58.9	637	64.8	72	72	16.5	147	108	11.8	1.3	0.117	11	40	<20 <sup>5)</sup>	<28 <sup>5)</sup>
<b>Trench length 1200 mm</b>																	
Boost stage	100	2681	41.5	3028	45.0	837	837	20.3	1588	1256	14.5	16.1	0.159	101	365	42	50
Design stages	80	2296	43.6	2592	47.3	626	626	19.7	1199	939	14.0	8.8	0.109	81	290	35	43
	60	1832	46.9	2069	51.2	411	411	18.8	797	617	13.4	4.8	0.084	57	205	26	34
	40	1351	52.3	1525	57.2	233	233	17.6	459	349	12.6	3.1	0.089	35	125	<20 <sup>5)</sup>	<28 <sup>5)</sup>
Minimum stage	20	954	59.7	1077	65.6	121	121	16.4	244	182	11.7	2.6	0.156	17	60	<20 <sup>5)</sup>	<28 <sup>5)</sup>
<b>Trench length 1700 mm</b>																	
Boost stage	100	4268	42.4	4819	45.9	1332	1332	20.3	2493	1998	14.4	24.4	0.150	163	585	44	52
Design stages	80	3654	44.5	4125	48.3	997	997	19.6	1882	1495	13.9	13.4	0.104	129	465	37	45
	60	2916	47.8	3292	52.0	654	654	18.7	1251	981	13.3	7.3	0.081	90	325	28	36
	40	2150	53.1	2428	58.0	370	370	17.5	720	556	12.5	4.8	0.089	54	195	<20 <sup>5)</sup>	<28 <sup>5)</sup>
Minimum stage	20	1518	60.4	1714	66.4	193	193	16.3	383	290	11.6	3.9	0.140	28	100	<20 <sup>5)</sup>	<28 <sup>5)</sup>
<b>Trench length 2000 mm</b>																	
Boost stage	100	5590	43.0	6311	46.5	1744	1744	20.3	3240	2617	14.4	34.7	0.163	213	765	45	53
Design stages	80	4785	45.0	5403	48.8	1305	1305	19.6	2445	1958	13.9	19.1	0.114	168	605	38	46
	60	3819	48.3	4312	52.6	857	857	18.7	1625	1285	13.3	10.4	0.088	118	425	29	37
	40	2816	53.6	3180	58.5	485	485	17.5	936	728	12.5	6.8	0.096	71	255	20	28
Minimum stage	20	1988	60.9	2245	66.8	253	253	16.3	498	380	11.6	5.6	0.161	35	125	<20 <sup>5)</sup>	<28 <sup>5)</sup>
<b>Trench length 2500 mm</b>																	
Boost stage	100	7138	43.6	8059	47.1	2228	2228	20.3	4107	3342	14.4	43.1	0.159	271	975	46	54
Design stages	80	6111	45.6	6900	49.3	1667	1667	19.6	3100	2501	13.9	23.7	0.110	215	775	39	47
	60	4877	48.8	5507	53.1	1094	1094	18.7	2060	1641	13.2	12.9	0.085	151	545	30	38
	40	3596	54.1	4061	59.0	619	619	17.5	1186	929	12.4	8.4	0.093	90	325	21	29
Minimum stage	20	2539	61.4	2867	67.3	323	323	16.2	631	485	11.6	6.9	0.155	44	160	<20 <sup>5)</sup>	<28 <sup>5)</sup>
<b>Trench length 3000 mm</b>																	
Boost stage	100	9517	44.3	10746	47.8	2970	2970	20.2	5430	4456	14.3	60.0	0.167	360	1295	47	55
Design stages	80	8148	46.2	9200	50.0	2222	2222	19.6	4098	3335	13.9	33.0	0.115	286	1030	41	49
	60	6503	49.5	7342	53.7	1459	1459	18.6	2723	2188	13.2	18.0	0.089	201	725	31	39
	40	4795	54.7	5414	59.6	826	826	17.4	1568	1239	12.4	11.7	0.097	121	435	22	30
Minimum stage	20	3385	61.9	3822	67.8	431	431	16.2	835	647	11.5	9.6	0.161	60	215	<20 <sup>5)</sup>	<28 <sup>5)</sup>

Q<sub>H</sub> [W] = Heat output; Q<sub>K</sub> [W] = Cooling output, total; Q<sub>S</sub> [W] = Cooling output, sensitive; t<sub>L</sub> [°C] = Leaving air temperature

<sup>1)</sup> at room temperature t<sub>L</sub> = 20°C

<sup>2)</sup> at room temperature t<sub>L</sub> = 27°C, rel. humidity 48%

<sup>3)</sup> Add an additional power consumption of 1 W per valve drive type 146906.

<sup>4)</sup> The sound pressure levels were calculated with an assumed room insulation of 8dB(A). This corresponds to a clearance of 2 m, a room volume of 100m<sup>3</sup> and a reverberation time of 0.5 s (according to VDI 2081).

<sup>5)</sup> Sound pressure level < 20 dB (A) and sound power level < 28 dB (A) outside the usual measuring and audible range.

<sup>6)</sup> Values rounded up within measurement tolerances.

# Katherm HK 360

## 2-pipe, trench height 210 mm

Technical drawings (all dimensions in mm)

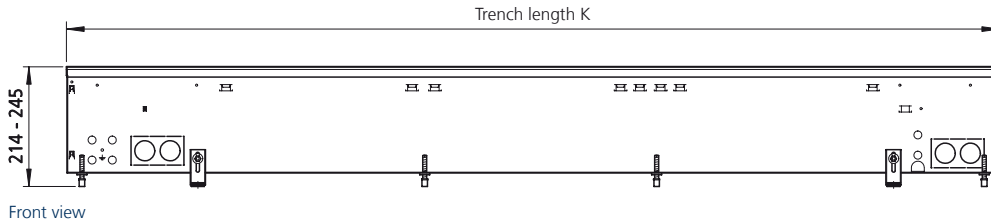

Front view

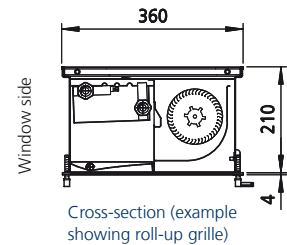

Cross-section (example showing roll-up grille)

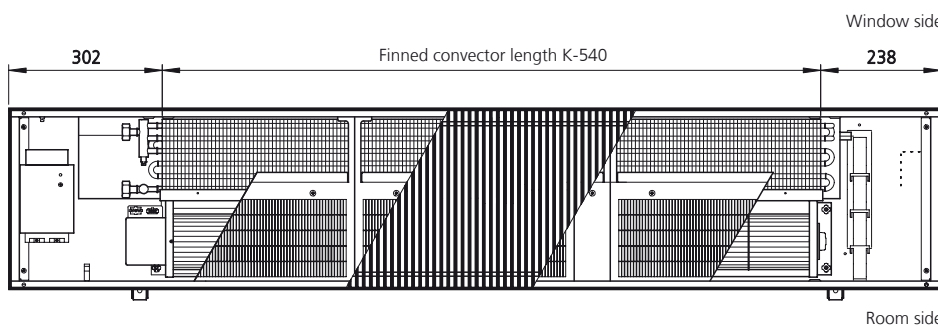

Top view (view without cover panel)

### Specifications

#### Connections:

Eurokonus, one-sided  
Connecting side for heating/cooling on left

#### Condensate connection:

15 mm spigots

Trench length	Finned convector length	Fan impellers	Fan motors
[mm]	[mm]	[Quantity]	[Quantity]
950	410	1	1
1200	660	1	1
1350	810	1	1
1850	1310	2	2
2250	1710	2	2

Make use of our online calculation programs to calculate your heat and cooling outputs and heating and cooling flow rates with a couple of clicks!

► [kampmanngroup.com/katherm-hk](http://kampmanngroup.com/katherm-hk)

### Water resistance

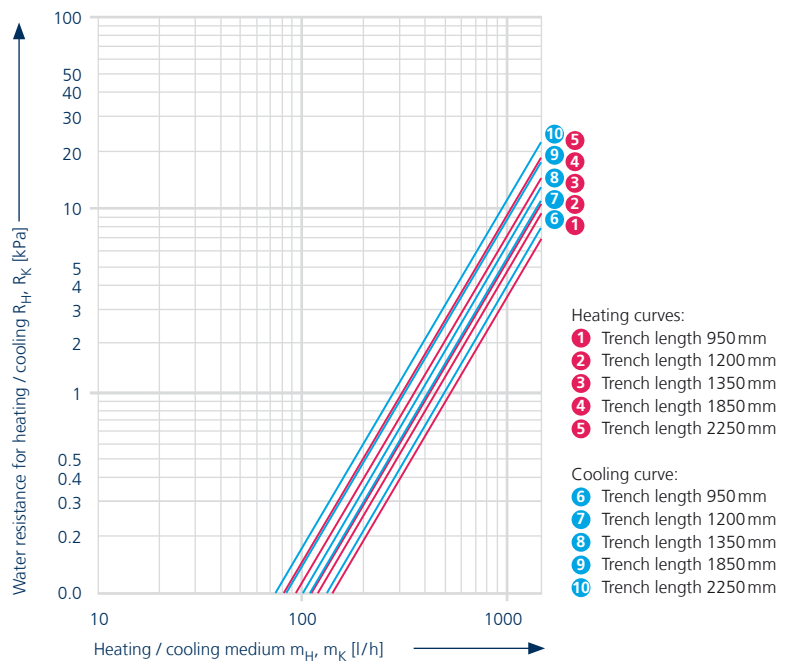

Outputs



Operating level	at speed setting	Heat outputs <sup>1)</sup>				Cooling outputs <sup>2)</sup>						Power consumption <sup>3)</sup>	Current consumption	Specific fan power	Air volume <sup>6)</sup>	Sound pressure level <sup>4)</sup>	Sound power level
		at LPHW 75 / 65 °C		at LPHW 82 / 71 °C		at CHW 16 / 18 °C			at CHW 7 / 12 °C								
		Q <sub>H</sub> [W]	t <sub>L2</sub> [°C]	Q <sub>H</sub> [W]	t <sub>L2</sub> [°C]	Q <sub>K</sub> [W]	Q <sub>S</sub> [W]	t <sub>L2</sub> [°C]	Q <sub>K</sub> [W]	Q <sub>S</sub> [W]	t <sub>L2</sub> [°C]						
<b>Trench length 950 mm</b>																	
Boost stage	100	4113	54.7	4694	58.8	816	816	19.8	1623	1318	14.9	11.5	111	0.110	104	51	59
Design stages	80	3418	54.4	3902	58.4	660	660	19.7	1317	1061	14.8	8.1	79	0.093	88	43	51
	60	2602	53.8	2971	57.8	477	477	19.6	952	759	14.6	5.2	50	0.076	68	33	41
	40	1699	52.8	1942	56.9	274	274	19.4	539	426	14.1	3.1	30	0.068	46	23	31
Minimum stage	20	887	50.0	1016	54.0	92	92	18.8	160	125	13.1	2.4	23	0.091	26	<20 <sup>5)</sup>	<28 <sup>5)</sup>
<b>Trench length 1200 mm</b>																	
Boost stage	100	6819	54.6	7782	58.6	1352	1352	19.8	2690	2184	14.9	21.6	209	0.124	174	52	60
Design stages	80	5667	54.3	6469	58.3	1094	1094	19.7	2184	1759	14.8	13.8	133	0.095	146	43	51
	60	4313	53.8	4925	57.9	790	790	19.6	1578	1258	14.6	7.2	70	0.064	113	34	42
	40	2817	52.7	3220	56.7	455	455	19.4	894	705	14.1	3.3	32	0.043	76	24	32
Minimum stage	20	1471	50.4	1685	54.5	152	152	18.8	266	208	13.1	2.8	27	0.065	43	<20 <sup>5)</sup>	<28 <sup>5)</sup>
<b>Trench length 1350 mm</b>																	
Boost stage	100	8442	54.7	9635	58.7	1674	1674	19.8	3331	2704	14.9	26.7	258	0.125	214	52	60
Design stages	80	7016	54.5	8009	58.5	1354	1354	19.7	2704	2177	14.8	17.0	165	0.095	179	44	52
	60	5340	53.9	6098	58.0	978	978	19.6	1953	1558	14.6	8.9	86	0.064	139	35	43
	40	3488	52.7	3986	56.8	563	563	19.4	1107	873	14.1	4.1	40	0.043	94	24	32
Minimum stage	20	1821	50.0	2086	54.0	189	189	18.8	329	257	13.1	3.4	33	0.063	54	<20 <sup>5)</sup>	<28 <sup>5)</sup>
<b>Trench length 1850 mm</b>																	
Boost stage	100	12771	54.7	14576	58.7	2533	2533	19.8	5039	4091	14.9	38.2	369	0.118	324	53	61
Design stages	80	10614	54.4	12116	58.4	2049	2049	19.7	4090	3294	14.8	25.2	243	0.093	272	45	53
	60	8078	53.8	9225	57.8	1480	1480	19.6	2955	2357	14.6	14.1	136	0.067	211	36	44
	40	5277	52.7	6030	56.7	851	851	19.4	1674	1321	14.1	7.2	70	0.050	143	26	34
Minimum stage	20	2755	50.0	3155	54.0	286	286	18.8	498	389	13.1	5.9	57	0.072	82	<20 <sup>5)</sup>	<28 <sup>5)</sup>
<b>Trench length 2250 mm</b>																	
Boost stage	100	16884	54.6	19270	58.6	3348	3348	19.8	6662	5409	14.9	53.4	516	0.124	429	55	63
Design stages	80	14032	54.4	16018	58.4	2708	2708	19.7	5408	4355	14.8	34.1	329	0.095	360	47	55
	60	10680	53.9	12196	58.0	1956	1956	19.6	3906	3116	14.6	17.9	173	0.064	278	37	45
	40	6976	52.7	7972	56.8	1125	1125	19.4	2213	1747	14.1	8.2	79	0.043	189	27	35
Minimum stage	20	3642	50.0	4171	54.0	378	378	18.8	658	515	13.1	6.9	66	0.064	108	<20 <sup>5)</sup>	<28 <sup>5)</sup>

Q<sub>H</sub> [W] = Heat output; Q<sub>K</sub> [W] = Cooling output, total; Q<sub>S</sub> [W] = Cooling output, sensitive; t<sub>L2</sub> [°C] = Leaving air temperature

1) at room temperature t<sub>L</sub> = 20 °C  
 2) at room temperature t<sub>L</sub> = 27 °C, rel. humidity 48%  
 3) Add an additional power consumption of 1 W per valve drive type 146906.  
 4) The sound pressure levels were calculated with an assumed room insulation of 8 dB(A). This corresponds to a distance of 2 m, a room volume of 100 m<sup>3</sup> and a reverberation time of 0.5 s (in accordance with VDI 2081).  
 5) Sound pressure level < 20 dB (A) and sound power level < 28 dB (A) outside the usual measuring and audible range.  
 6) Values rounded up within measurement tolerances.



# Katherm HK 360

## 4-pipe, trench height 210 mm

Technical drawings (all dimensions in mm)

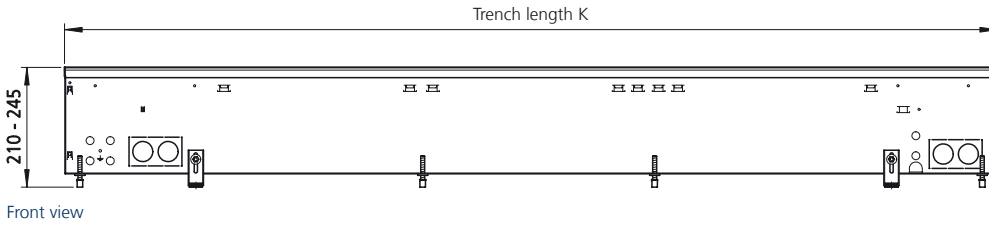

Front view

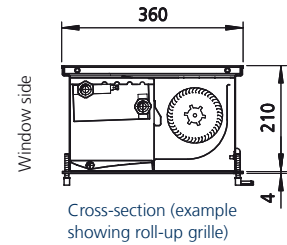

Cross-section (example showing roll-up grille)

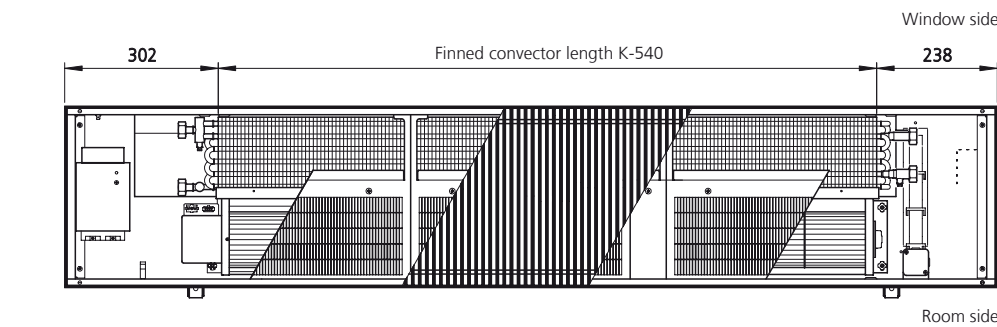

Top view (view without cover panel)

### Specifications

#### Connections:

Eurokonus, opposite end  
 Connection side for cooling on left  
 Heating connection on right

#### Condensate connection:

15 mm spigots

Trench length	Finned convector length	Fan impellers	Fan motors
[mm]	[mm]	[Quantity]	[Quantity]
950	410	1	1
1200	660	1	1
1350	810	1	1
1850	1310	2	2
2250	1710	2	2

### Water resistance

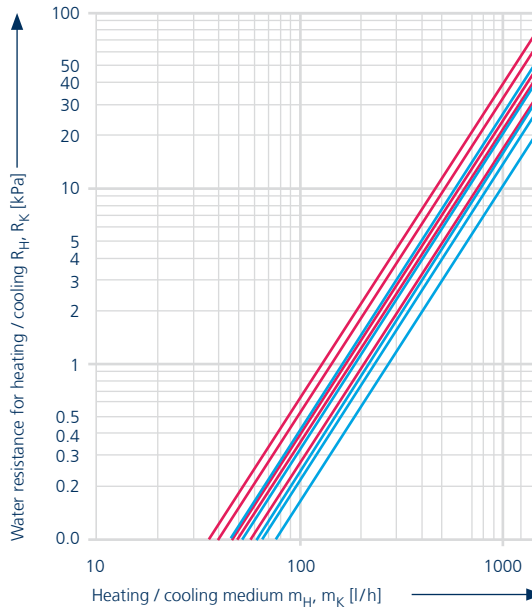

Heating curves:

- 1 Trench length 950 mm
- 2 Trench length 1200 mm
- 3 Trench length 1350 mm
- 4 Trench length 1850 mm
- 5 Trench length 2250 mm

Cooling curve:

- 6 Trench length 950 mm
- 7 Trench length 1200 mm
- 8 Trench length 1350 mm
- 9 Trench length 1850 mm
- 10 Trench length 2250 mm

Make use of our online calculation programs to calculate your heat and cooling outputs and heating and cooling flow rates with a couple of clicks!

► [kampmanngroup.com/katherm-hk](http://kampmanngroup.com/katherm-hk)

Outputs



Operating level	at speed setting	Heat outputs <sup>1)</sup>				Cooling outputs <sup>2)</sup>						Power consumption <sup>3)</sup>	Current consumption	Specific fan power	Air volume <sup>6)</sup>	Sound pressure level <sup>4)</sup>	Sound power level
		at LPHW 75 / 65 °C		at LPHW 82 / 71 °C		at CHW 16 / 18 °C			at CHW 7 / 12 °C								
		Q <sub>H</sub> [W]	t <sub>L2</sub> [°C]	Q <sub>H</sub> [W]	t <sub>L2</sub> [°C]	Q <sub>K</sub> [W]	Q <sub>S</sub> [W]	t <sub>L2</sub> [°C]	Q <sub>K</sub> [W]	Q <sub>S</sub> [W]	t <sub>L2</sub> [°C]						
<b>Trench length 950 mm</b>																	
Boost stage	100	2982	45,4	3404	49.1	768	768	19,7	1528	1241	14,7	11.5	111	0.110	104	51	59
Design stages	80	2478	45,2	2829	48.8	621	621	19,6	1240	999	14,6	8.1	79	0.093	88	43	51
	60	1886	44,6	2154	48.2	449	449	19,5	896	715	14,4	5.2	50	0.076	68	33	41
	40	1232	43,8	1408	47.4	258	258	19,3	508	401	14,0	3.1	30	0.068	46	23	31
Minimum stage	20	643	41,3	737	44.8	87	87	18,8	151	118	13,0	2.4	23	0.091	26	<20 <sup>5)</sup>	<28 <sup>5)</sup>
<b>Trench length 1200 mm</b>																	
Boost stage	100	4944	45,3	5643	49.0	1273	1273	19,7	2533	2057	14,7	21.6	209	0.124	174	52	60
Design stages	80	4109	45,0	4691	48.7	1030	1030	19,6	2056	1656	14,6	13.8	133	0.095	146	43	51
	60	3127	44,7	3571	48.3	744	744	19,5	1486	1185	14,4	7.2	70	0.064	113	34	42
	40	2043	43,6	2335	47.2	428	428	19,3	842	664	14,0	3.3	32	0.043	76	24	32
Minimum stage	20	1066	41,7	1221	45.2	144	144	18,8	250	196	13,0	2.8	27	0.065	43	<20 <sup>5)</sup>	<28 <sup>5)</sup>
<b>Trench length 1350 mm</b>																	
Boost stage	100	6121	45,4	6986	49.1	1576	1576	19,7	3137	2547	14,7	26.7	258	0.125	214	52	60
Design stages	80	5087	45,2	5807	48.9	1275	1275	19,6	2546	2050	14,6	17.0	165	0.095	179	44	52
	60	3872	44,7	4422	48.4	921	921	19,5	1839	1467	14,4	8.9	86	0.064	139	35	43
	40	2529	43,7	2890	47.3	530	530	19,3	1042	822	14,0	4.1	40	0.043	94	24	32
Minimum stage	20	1320	41,3	1512	44.8	178	178	18,8	310	242	13,0	3.4	33	0.063	54	<20 <sup>5)</sup>	<28 <sup>5)</sup>
<b>Trench length 1850 mm</b>																	
Boost stage	100	9261	45,4	10569	49.1	2385	2385	19,7	4745	3853	14,7	38.2	369	0.118	324	53	61
Design stages	80	7696	45,1	8785	48.8	1929	1929	19,6	3852	3102	14,6	25.2	243	0.093	272	45	53
	60	5858	44,6	6689	48.3	1394	1394	19,5	2782	2219	14,4	14.1	136	0.067	211	36	44
	40	3826	43,6	4373	47.2	802	802	19,3	1576	1244	14,0	7.2	70	0.050	143	26	34
Minimum stage	20	1998	41,3	2288	44.8	269	269	18,8	469	367	13,0	5.9	57	0.072	82	<20 <sup>5)</sup>	<28 <sup>5)</sup>
<b>Trench length 2250 mm</b>																	
Boost stage	100	12243	45,3	13973	49.0	3153	3153	19,7	6273	5093	14,7	53.4	516	0.124	429	55	63
Design stages	80	10175	45,1	11615	48.8	2550	2550	19,6	5092	4101	14,6	34.1	329	0.095	360	47	55
	60	7744	44,7	8843	48.4	1842	1842	19,5	3679	2934	14,4	17.9	173	0.064	278	37	45
	40	5058	43,7	5781	47.3	1060	1060	19,3	2084	1645	14,0	8.2	79	0.043	189	27	35
Minimum stage	20	2641	41,3	3025	44.8	356	356	18,8	620	485	13,0	6.9	66	0.064	108	<20 <sup>5)</sup>	<28 <sup>5)</sup>

Q<sub>H</sub> [W] = Heat output; Q<sub>K</sub> [W] = Cooling output, total; Q<sub>S</sub> [W] = Cooling output, sensitive; t<sub>L2</sub> [°C] = Leaving air temperature

1) at room temperature t<sub>L</sub> = 20 °C  
 2) at room temperature t<sub>L</sub> = 27 °C, rel. humidity 48%  
 3) Add an additional power consumption of 1 W per valve drive type 146906.  
 4) The sound pressure levels were calculated with an assumed room insulation of 8 dB(A). This corresponds to a distance of 2 m, a room volume of 100 m<sup>3</sup> and a reverberation time of 0.5 s (in accordance with VDI 2081).  
 5) Sound pressure level < 20 dB (A) and sound power level < 28 dB (A) outside the usual measuring and audible range.  
 6) Values rounded up within measurement tolerances.

# 03 ▶ Design information

---





## Information on planning and design

Katherm HK are suitable for use in all kinds of buildings in which there is a cooling load owing to internal loads and the effects of sunlight.

They are generally positioned directly in front of the external façade without a large gap. Katherm HK can provide cost-effective and efficient heating, particularly in front of large areas of glazing.

### Air outlet

Katherm HK 320, HK 290 and HK 360 are positioned with the air outlet to the external wall. If the air outlet is arranged on the room side, the high air flow rate will lower levels of comfort in the public area.

### Acoustics

When designing a system, it should be noted that disruptive noise may occur at higher fan speeds. The respective sound power levels of Katherm HK are indicated in the tables (see "Technical Data"). The sound pressure levels were calculated with an assumed room insulation of 8 dB(A). This corresponds to a distance of 2 m, a room volume of 100 m<sup>3</sup> and a reverberation time of 0.5 s (in accordance with VDI 2081).

As the sound level is not only due to the Katherm HK, but is also influenced by the number of Katherm HK and also very significantly by the acoustic characteristics of the room, the actual figure may vary in practice.

We would recommend designing Katherm HK taking into account the respective permitted sound pressure level in the room.

### Heat and cooling outputs

The heat and cooling outputs were calculated based on DIN EN 16430. We would recommend our online calculation programs to convert to other operating conditions:  
[kampmanngroup.com/katherm-hk](http://kampmanngroup.com/katherm-hk).

### Comfort

Comfort was calculated taking into consideration DIN EN ISO 7730 (May 2006) "Ergonomics of the thermal environment – analytical determination and interpretation of thermal comfort by calculation of the PMV and the PDB indexes and criteria of local thermal comfort (ISO 7730).

The air outlet and air flows are optimised in detail in accordance with this standard.

Make use of our online calculation programs to calculate your heat and cooling outputs and heating and cooling flow rates with a couple of clicks!

► [kampmanngroup.com//katherm-hk](http://kampmanngroup.com//katherm-hk)

## Water connections – Pipe openings

**Katherm HK 290, 2-pipe, trench height 160 mm**

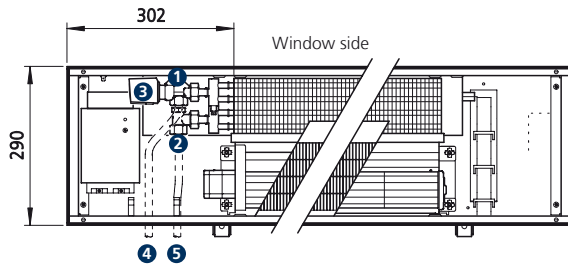

Top view

- 1 1/2" valve body, axial, type 346914 and/or type 346911 (flow-dependent)
- 2 1/2" return shut-off valve, angled, type 145953
- 3 Thermoelectric actuator, type 146906  
Alternatively: valve kit type 143241 or type 143211 (flow-dependent)
- 4 Heating/Cooling flow
- 5 Heating/cooling return

**Katherm HK 290, 4-pipe, trench height 160 mm**

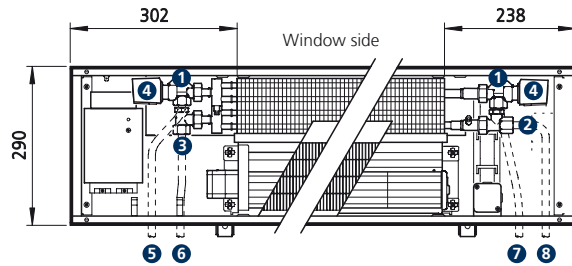

Top view

- 1 1/2" valve body, axial, type 346914 and/or type 346911 (flow-dependent)
- 2 1/2" return shut-off valve, straight, type 145952
- 3 1/2" return shut-off valve, angled, type 145953
- 4 Thermoelectric actuator, type 146906  
Alternatively: valve kit type 143441 or type 143411 (flow-dependent)
- 5 Flow pipe for cooling
- 6 Return pipe for cooling
- 7 Flow pipe for heating
- 8 Heating return

**Katherm HK 320, 2-pipe, trench height 130 mm**

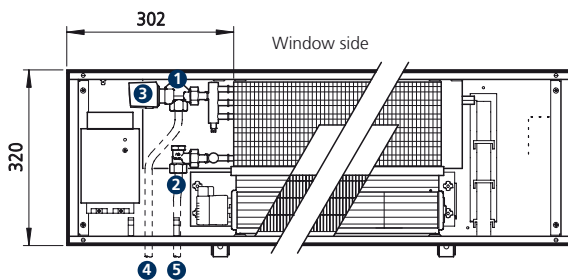

Top view

- 1 1/2" valve body, axial, type 346914 and/or type 346911 (flow-dependent)
- 2 1/2" return shut-off valve, angled, type 145953
- 3 Thermoelectric actuator, type 146906  
Alternatively: valve kit type 143241 or type 143211 (flow-dependent)
- 4 Heating/Cooling flow
- 5 Heating/cooling return

**Katherm HK 320, 4-pipe, trench height 130 mm**

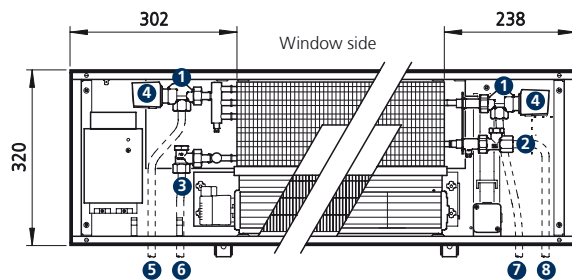

Top view

- 1 1/2" valve body, axial, type 346914 and/or type 346911 (flow-dependent)
- 2 1/2" return shut-off valve, straight, type 145952
- 3 1/2" return shut-off valve, angled, type 145953
- 4 Thermoelectric actuator, type 146906  
Alternatively: valve kit type 143441 or type 143411 (flow-dependent)
- 5 Flow pipe for cooling
- 6 Return pipe for cooling
- 7 Flow pipe for heating
- 8 Heating return

**Katherm HK 360, 2-pipe, trench height 210 mm**

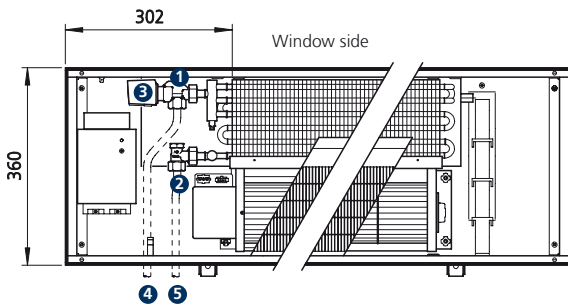

Top view

- ① 1/2" valve body, axial, for higher flow, type 346914
- ② 1/2" return shut-off valve, for higher flow, angled, type 145955
- ③ Thermoelectric actuator, type 146906  
Alternatively: valve kit type 143241
- ④ Heating/Cooling flow
- ⑤ Heating/cooling return

**Katherm HK 360, 4-pipe, trench height 210 mm**

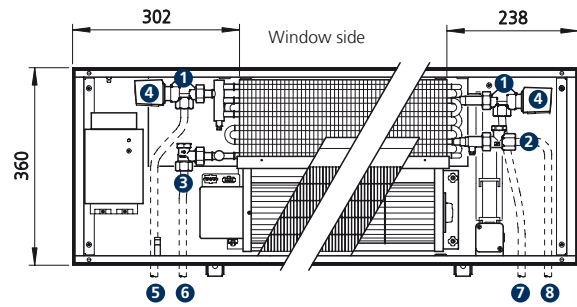

Top view

- ① 1/2" valve body, axial, for higher flow, type 346914
- ② 1/2" return shut-off valve, straight, type 145954
- ③ 1/2" return shut-off valve, angled, type 145955
- ④ Thermoelectric actuator, type 146906  
Alternatively: valve kit type 143441
- ⑤ Flow pipe for cooling
- ⑥ Return pipe for cooling
- ⑦ Flow pipe for heating
- ⑧ Heating return

# 04 ▶ Controls

## 24V electromechanical model

Model for complete on-site control of Katherm HK (not for Katherm HK 360) or via convenient clock thermostats.

### Product features

- ▶ The operating voltage must be provided by a central on-site 24 V DC voltage supply.
- ▶ External power supply ensures space-saving connections in the floor trench so that the hydraulic connection can be conveniently performed.
- ▶ In the event of a motor fault, e.g. overloading, the fault signal is internally evaluated and the fan is automatically disabled.

### Electromechanical control type 30456

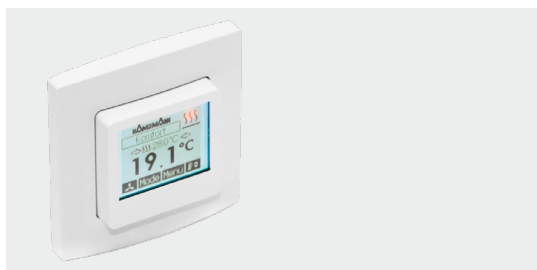

Flush-mounted clock thermostat with 10-stage fan speed setting including day and week programme

### Product features

- ▶ large illuminated display with four sensor keys
- ▶ can be integrated into any 50 x 50 switch program
- ▶ can be integrated using an intermediate frame into a 55 x 55 switch program
- ▶ white cover panel and frame (similar to RAL 9010)
- ▶ integral room temperature sensor
- ▶ room/frost protection function (temperature measurement within the clock thermostats)
- ▶ integrated day or weekly program timer programs with automatic summer/winter changeover
- ▶ 24V operating and output voltage (0-10V fan control)

### Connection values for HK 320, trench height 130 mm

Trench length	Power consumption	Current consumption
[mm]	P [W]	I [A]
915	Max. 8	Max. 0.09
1200	Max. 12	Max. 0.12
1700	Max. 17	Max. 0.17
2000	Max. 23	Max. 0.24
2500	Max. 28	Max. 0.29
3000	Max. 33	Max. 0.34

### Connection values for HK 290, trench height 160 mm

Trench length	Power consumption	Current consumption
[mm]	P [W]	I [A]
950	Max. 9	Max. 0.08
1200	Max. 17	Max. 0.15
1700	Max. 25	Max. 0.22
2000	Max. 35	Max. 0.31
2500	Max. 44	Max. 0.39
3000	Max. 60	Max. 0.54

The power and current consumption of the actuators (1 W) is not taken into account.



## Electrical cabling – control via clock thermostat, type 30456

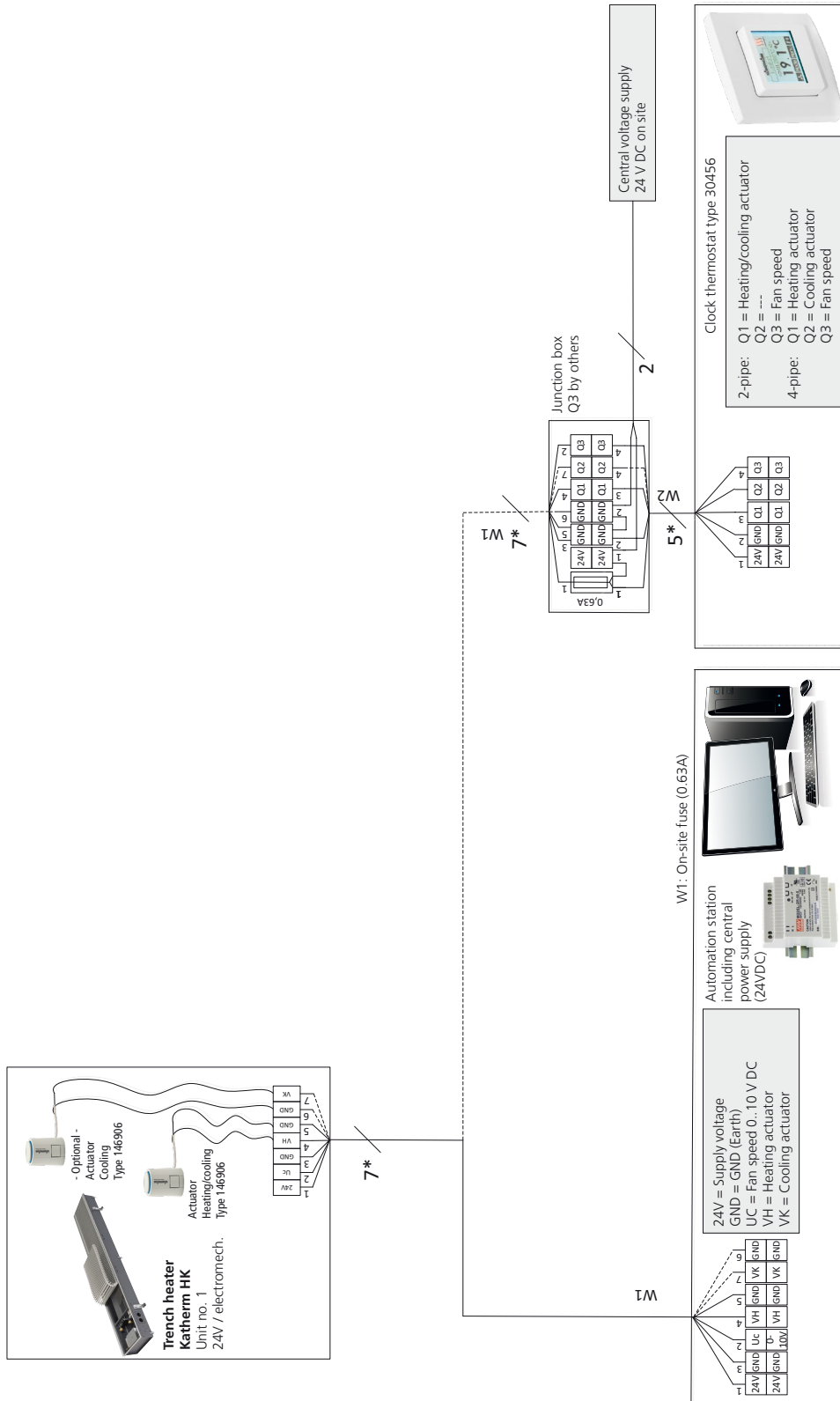

\* Lay shielded cables (e.g. IY(ST)Y, 0.8 mm) separately from high-voltage cables.  
W1: Voltage supply (on-site fuse, 0.64 A) and control signal for fan and actuator.

## 230 V electromechanical model

Design for on-site control or for room regulation with intuitive operation of the Katherm HK.

### Product features

- ▶ the Katherm HK has a built-in 230 V AC power supply
- ▶ any motor fault, for instance overloading, is analysed by the electronics within the EC motor
- ▶ Kampmann offers an extensive range of control accessories for all required functions

### Room thermostat type 30155



Room thermostat for 3-stage speed control for surface wall-mounted installation in an attractive retrained design

### Product features

- ▶ colour: pure white (similar to RAL 9010)
- ▶ user-friendly
- ▶ functional and robust design
- ▶ 2- and 4-pipe applications
- ▶ Day/ECO/Off operating mode with room frost protection function
- ▶ built-in room sensor, connection option for external room sensor
- ▶ digital input for switch-over between ECO and OFF
- ▶ digital output for heating/cooling changeover with 2-pipe systems
- ▶ only in conjunction with 230 V actuator, type 146905

### Connection values for HK 320, trench height 130 mm

Trench length	Power consumption	Current consumption
[mm]	P [W]	I [A]
915	Max. 8	Max. 0.09
1200	Max. 12	Max. 0.12
1700	Max. 17	Max. 0.17
2000	Max. 23	Max. 0.24
2500	Max. 28	Max. 0.29
3000	Max. 33	Max. 0.34

### Connection values for HK 290, trench height 160 mm

Trench length	Power consumption	Current consumption
[mm]	P [W]	I [A]
950	Max. 9	Max. 0.08
1200	Max. 17	Max. 0.15
1700	Max. 25	Max. 0.22
2000	Max. 35	Max. 0.31
2500	Max. 44	Max. 0.39
3000	Max. 60	Max. 0.54

### Connection values for HK 360, trench height 210 mm

Trench length	Power consumption	Current consumption
[mm]	P [W]	I [A]
950	Max. 12	Max. 0.11
1200	Max. 22	Max. 0.21
1350	Max. 27	Max. 0.26
1850	Max. 39	Max. 0.37
2250	Max. 54	Max. 0.52

The power and current consumption of the actuators (1 W) is not taken into account.

**Climate controller type 14894x**

Electronic climate controller, flush-mounted, for the control of EC fan heaters

**Product features**

- ▶ 2.5" LCD display with automatic back light
- ▶ high-quality glass surface with capacitive keys
- ▶ black and white
- ▶ 2- and 4-pipe applications
- ▶ optional: automatic fan, five manually selectable fan stages
- ▶ configuration of three timer channels, each with four changeover points
- ▶ built-in room sensor, connection option for external room sensor
- ▶ digital input (potential-free) for Eco/Day, Heating/Cooling changeover, window contact etc.
- ▶ digital input (230 V AC) for Eco/Day, Heating/Cooling changeover, window contact etc.
- ▶ optionally with Modbus interface
- ▶ only in conjunction with 230 V actuator, type 146905

### Electrical cabling - BMS control

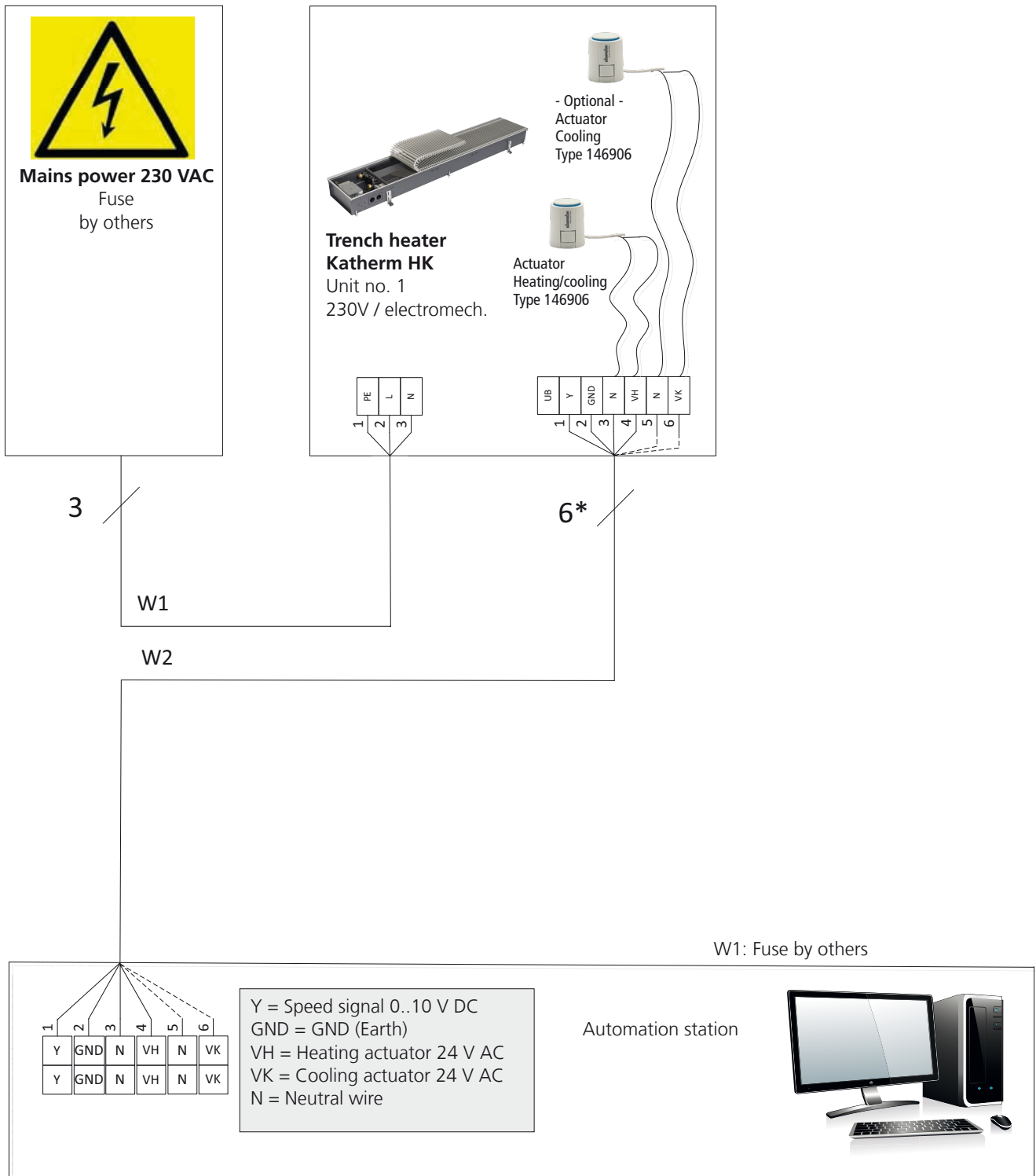

\* Lay shielded cables (e.g. IY(ST)Y, 0.8 mm), separately from high-voltage cables.  
W1: Voltage supply (fuse by others)  
W2: Control signal for fan and actuator



## Electrical cabling – climate controller actuation type 14894x

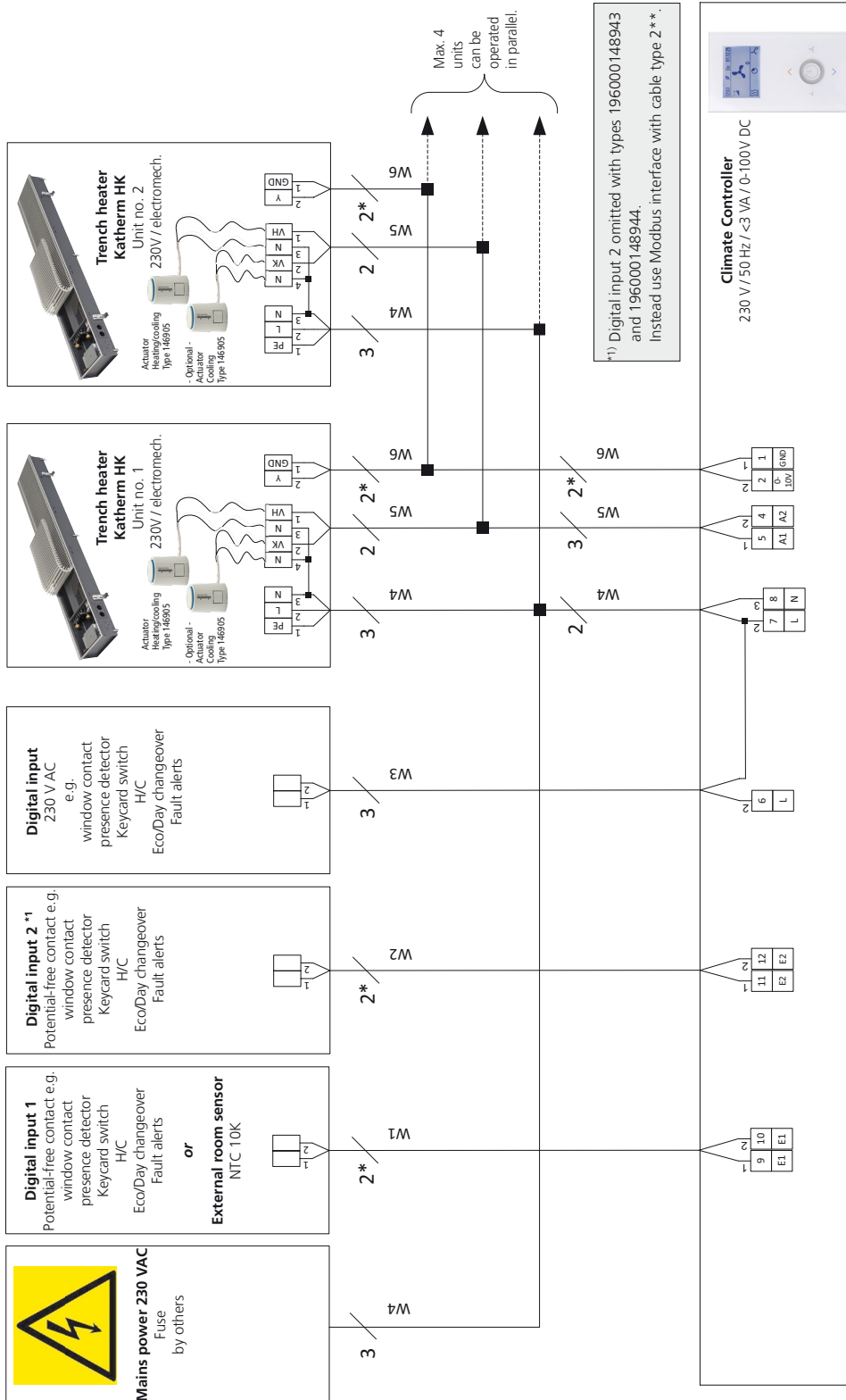

\* Lay shielded cables (e.g. IY(ST)Y, 0.8 mm) separately from high-voltage cables.

\*\* Shielded, paired cables, e.g. UNITRONIC® BUS LD 2 x 2 x 0.22

W1: Digital input 1 (optional)

W2: Digital input 2 (optional)

W3: Digital input 230 V AC (optional)

W4: Power supply

W5: Control signal for valves

W6: Control signal for the fan

### Electrical cabling – Control via room thermostat, type 30155

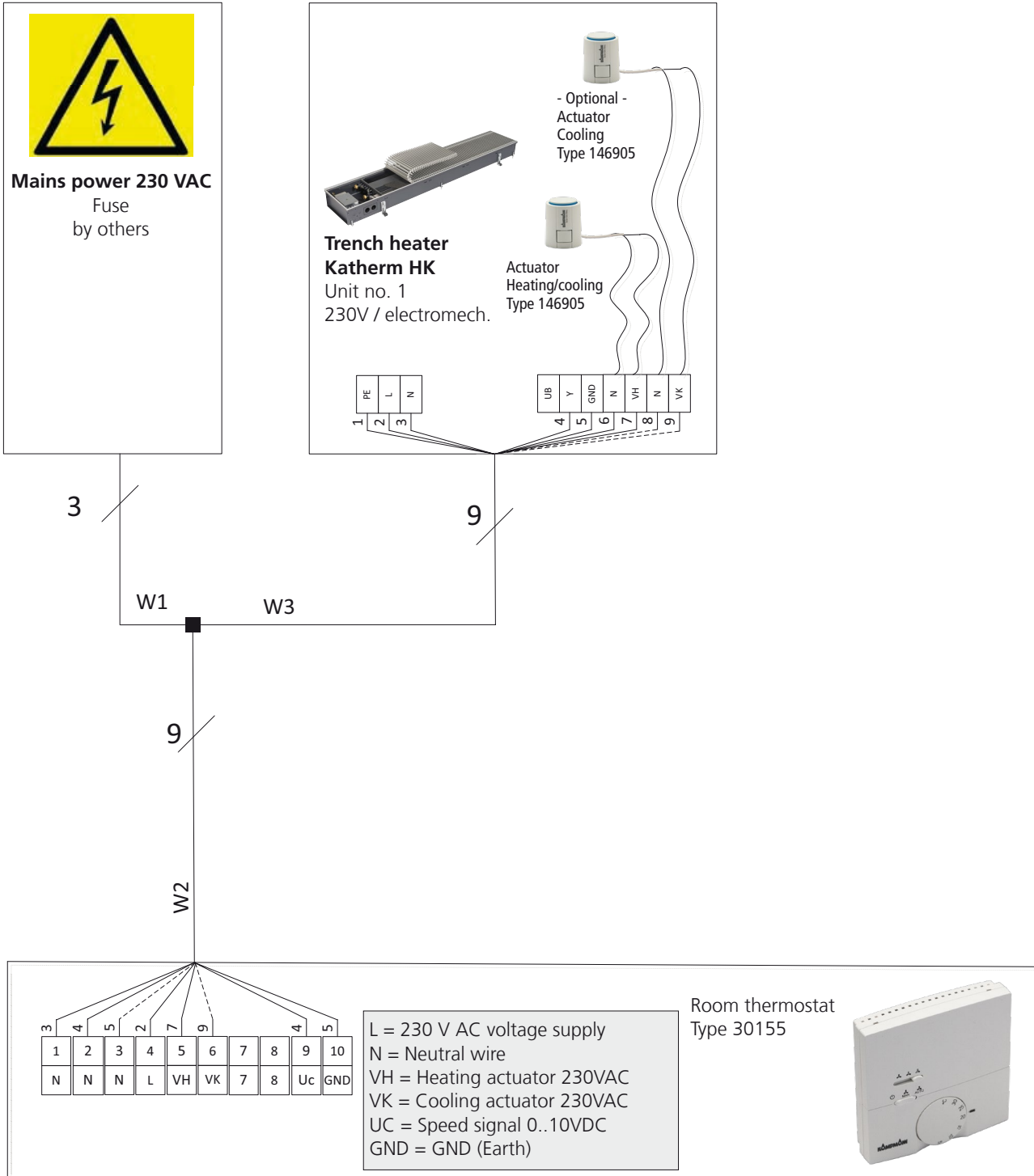

W1: Voltage supply (fuse by others)  
 W2: Voltage supply, control signal for fan and actuator.  
 W3: Voltage supply, control signal for fan and actuator.

# KaControl model

The all-inclusive solution for room automation and networking

## Product features

- ▶ A high-performance parametrised microprocessor is designed to carry out all necessary functions. Each unit therefore is equipped with its own "intelligence" and can be operated in groups via Kampmann networks.

## Connection to building automation systems

- ▶ Units with KaControl can be equipped with plug-in communication interfaces for CANbus individual room control or for linking into higher-order control systems: BACnet, LON, KNX and Modbus. Direct control via an active 0-10 V signal from the on-site building management system is alternatively possible.

## Motor protection

- ▶ Any faults with the motor e.g. overloading are analysed by the electronics within the EC motor. This then switches the fan off.

## KaControl

The parametrisable KaControl offers a wide range of functions:

- ▶ optional: 5 fan speed settings; manually adjustable
- ▶ valve control for 2- and 4-pipe applications for thermoelectric valve actuators 24 V DC OPEN/CLOSE
- ▶ integrated timer program for programming day and week switching functions in the KaController unit
- ▶ motor monitoring with fault signal processing

## Connection values for HK 320, trench height 130 mm

Trench length	Power consumption	Current consumption
[mm]	P [W]	I [A]
915	Max. 8	Max. 0.09
1200	Max. 12	Max. 0.12
1700	Max. 17	Max. 0.17
2000	Max. 23	Max. 0.24
2500	Max. 28	Max. 0.29
3000	Max. 33	Max. 0.34

## Connection values for HK 290, trench height 160 mm

Trench length	Power consumption	Current consumption
[mm]	P [W]	I [A]
950	Max. 9	Max. 0.08
1200	Max. 17	Max. 0.15
1700	Max. 25	Max. 0.22
2000	Max. 35	Max. 0.31
2500	Max. 44	Max. 0.39
3000	Max. 60	Max. 0.54

## Connection values for HK 360, trench height 210 mm

Trench length	Power consumption	Current consumption
[mm]	P [W]	I [A]
950	Max. 12	Max. 0.11
1200	Max. 22	Max. 0.21
1350	Max. 27	Max. 0.26
1850	Max. 39	Max. 0.37
2250	Max. 54	Max. 0.52

The power and current consumption of the actuators (1 W) is not taken into account.

### KaController operating unit



The "face" of the KaControl building automation system the KaController operating unit.

With a large display and one-touch operation, the KaController is very easy to use. With the basic principle, "as little as possible, as much as required", even untrained users can intuitively get to grips with the control options.

The basic functions for comfortable interior temperatures are set in a user-friendly way using the KaController.

#### Product features

- ▶ room control unit, wall-mounted, high-grade design
- ▶ available with or without function buttons on the side
- ▶ plastic housing, white (similar to RAL 9010) and black (similar to RAL 9017) (only available in black without side function keys)
- ▶ communication interface to Kampmann T-LAN bus system
- ▶ large display with automatic back light
- ▶ integral room temperature sensor
- ▶ push-turn navigator dial with endless turn/lock function
- ▶ built-in weekly switching program
- ▶ password-protected parameter level

### KaControl SEL control panel



For the central control and monitoring of up to 24 temperature zones, units groups or rooms.

#### Product features

- ▶ 3 timer programs for 24 zones
- ▶ summer compensation
- ▶ room temperature setpoints / actual values
- ▶ central heating / cooling switch-over in 2-pipe systems by external switching contact
- ▶ centralised temperature target value specification by an external signal 0 – 10V
- ▶ demand for heating via digital output
- ▶ demand for cooling via digital output
- ▶ collective fault alert in Kampmann system via digital output
- ▶ fault detection in chiller or heat pump
- ▶ heating/cooling changeover
- ▶ heat generator enabled
- ▶ chiller or heating/cooling heat pump activation
- ▶ fault monitoring in single units (only if all units have Modbus cards, max. 24)
- ▶ switch-over of individual control zones:
  - ▶ ON/OFF or ECO/DAY
  - ▶ ON/OFF or ECO/DAY Total system via external contact
- ▶ BACnet gateway optional



# Electrical cabling – KaControl, BMS control

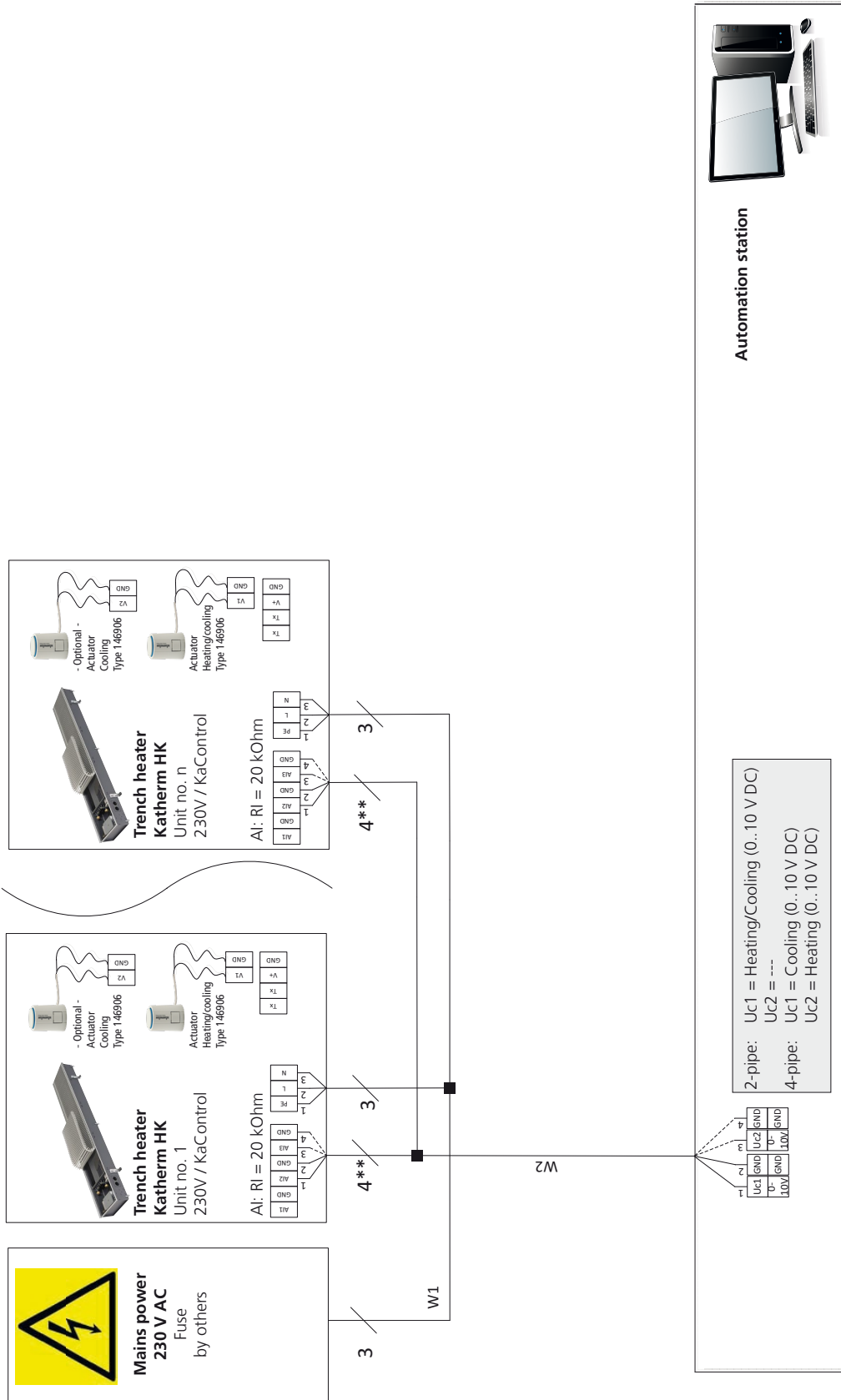

\* Lay shielded cables (e.g. IY(ST)Y, 0.8 mm), separately from high-voltage cables.  
 \*\* Lay shielded, paired cables, e.g. UNITRONIC® BUS LD 2x2x0.22 or of the same value, separately from power cables!  
 W1: Power supply  
 W2: Voltage supply, control signal for fan and actuator.

## Electrical cabling - KaControl, master unit and slave units

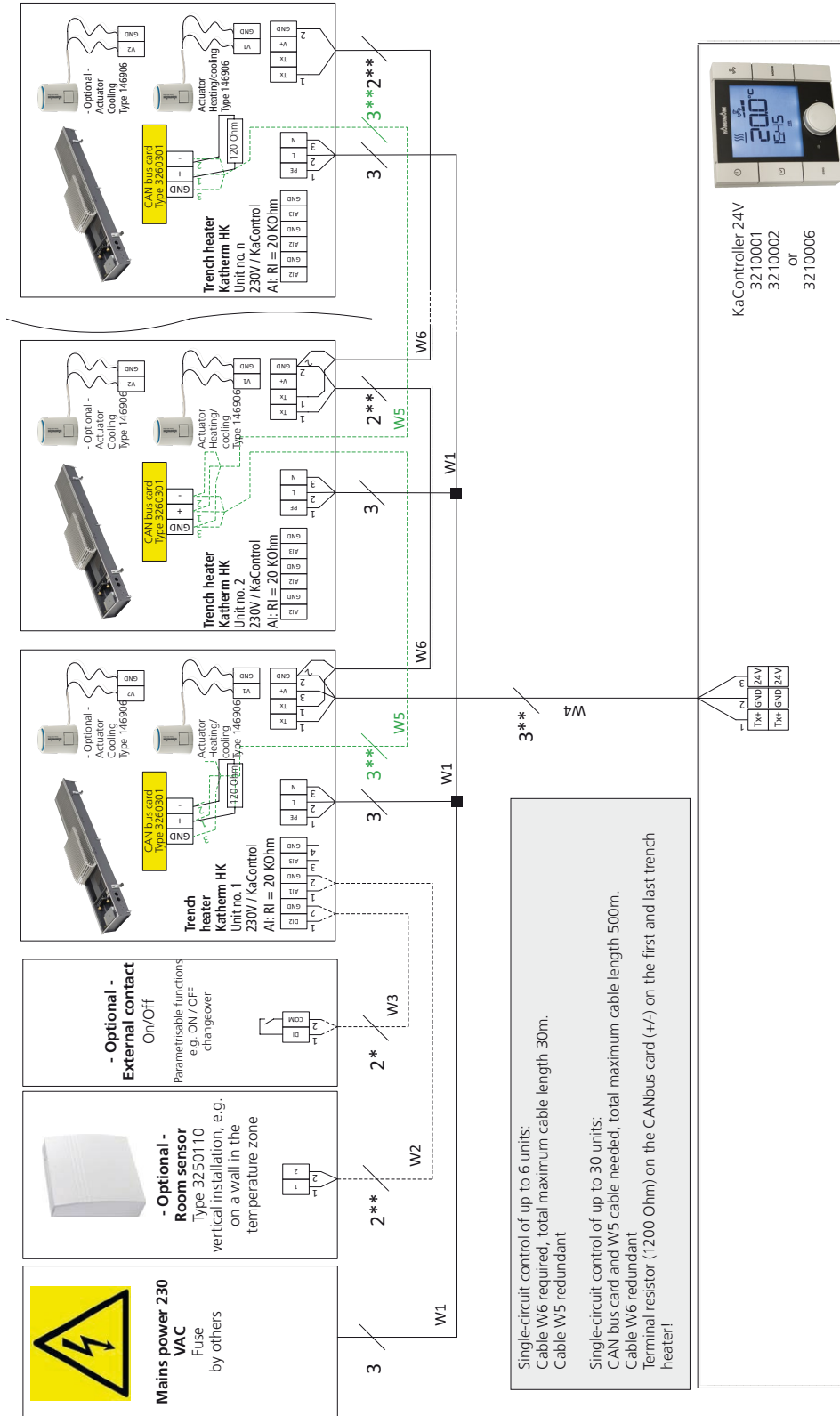

\* Lay shielded cables (e.g. IY(ST)Y, 0.8 mm) separately from high-voltage cables.

\*\* Lay shielded, paired cables, e.g. UNITRONIC® BUS LD 2x2x0.22 or of the same value, separately from power cables!

W1: Power supply

W2: Analogue input AI1 (optionally connectible), max. cable length 10 m, from 1 mm<sup>2</sup> 30 m, disconnect factory-fitted intake sensor

W3: Digital input DI1 (optionally connectible), max. cable length 30 m, from 1 mm<sup>2</sup> 100 m

W4, W6: Bus signal (tLan), max. cable length in each case 30 m

W5: Bus signal (CANbus) Only needed in a single-circuit control of up to 30 units.

## Electrical cabling – KaControl, control via SEL control panel

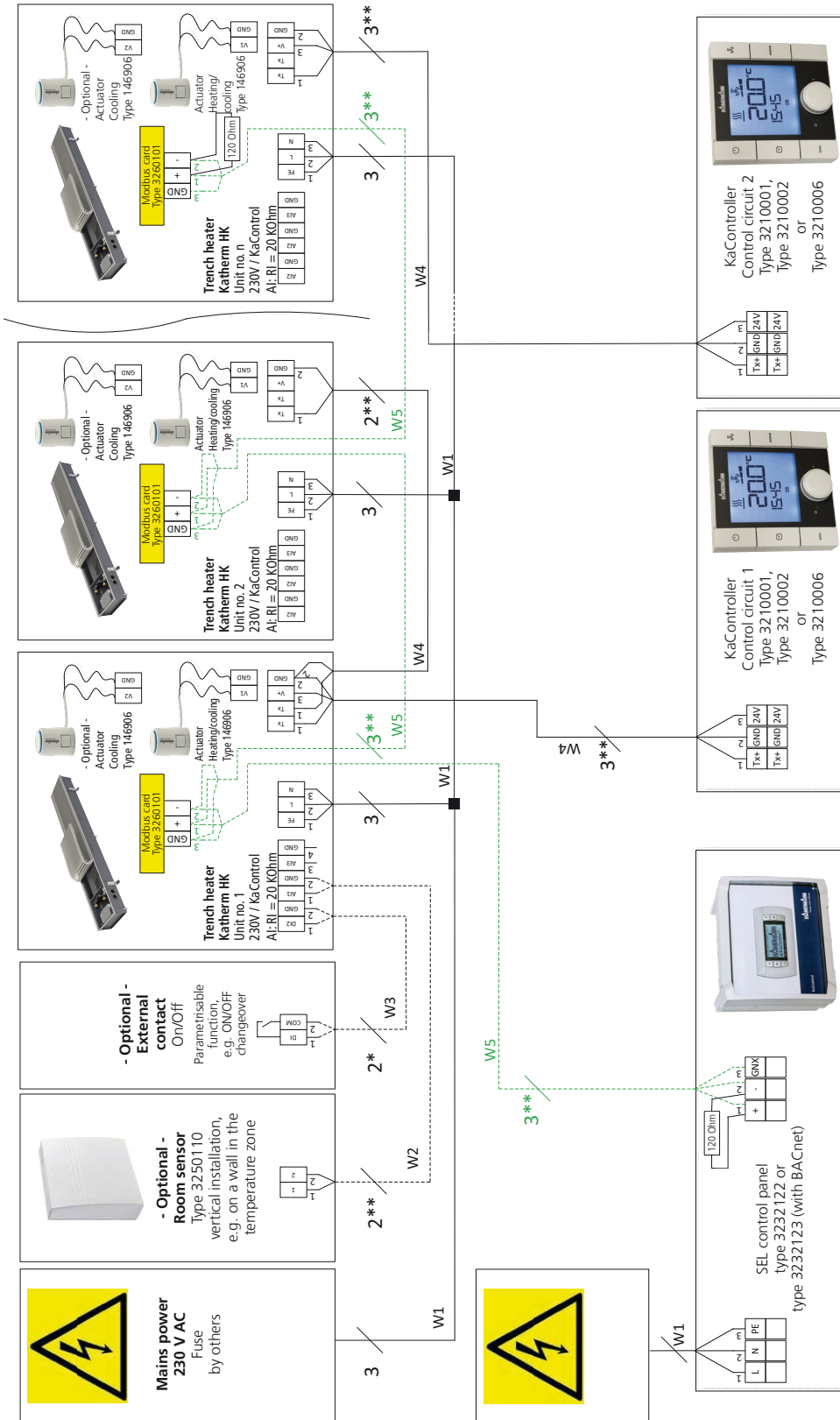

\* Lay shielded cables (e.g. IY(ST)Y, 0.8 mm) separately from high-voltage cables.

\*\* Lay shielded, paired cables, e.g. UNITRONIC® BUS LD 2x2x0.22 or of the same value, separately from power cables!

W1: Power supply

W2: Analogue input AI1 (optionally connectible), max. cable length 10 m, from 1 mm² 30 m, disconnect factory-fitted intake sensor

W3: Digital input DI1 (optionally connectible), max. cable length 30 m, from 1 mm² 100 m

W4: Bus signal (tLan), max. cable length in each case 30 m

W5: Bus signal (Modbus)

# 05 ▶ Ordering information

## Katherm HK

Design	Trench width	Trench height	2-/4-pipe	Grille finish	Art. no.
	[mm]	[mm]			
<b>KaControl model</b>					
HK 320	320	130	2-pipe	Roll-up grille	143322311113C1
				Linear grille	143322331113C1
			4-pipe	Roll-up grille	143324311113C1
				Linear grille	143324331113C1
HK 290	290	160	2-pipe	Roll-up grille	143292611114C1
				Linear grille	143292631114C1
			4-pipe	Roll-up grille	143294611114C1
				Linear grille	143294631114C1
HK 360	360	210	2-pipe	Roll-up grille	143362211114C1
				Linear grille	143362231114C1
			4-pipe	Roll-up grille	143364211114C1
				Linear grille	143364231114C1
<b>230 V electromechanical model</b>					
HK 320	320	130	2-pipe	Roll-up grille	14332231111300
				Linear grille	14332233111300
			4-pipe	Roll-up grille	14332431111300
				Linear grille	14332433111300
HK 290	290	160	2-pipe	Roll-up grille	14329261111400
				Linear grille	14329263111400
			4-pipe	Roll-up grille	14329461111400
				Linear grille	14329463111400
HK 360	360	210	2-pipe	Roll-up grille	14336221111400
				Linear grille	14336223111400
			4-pipe	Roll-up grille	14336421111400
				Linear grille	14336423111400
<b>24 V electromechanical model</b>					
HK 320	320	130	2-pipe	Roll-up grille	14332231111324
				Linear grille	14332233111324
			4-pipe	Roll-up grille	14332431111324
				Linear grille	14332433111324
HK 290	290	160	2-pipe	Roll-up grille	14329261111424
				Linear grille	14329263111424
			4-pipe	Roll-up grille	14329461111424
				Linear grille	14329463111424

0→0→

Trench units are supplied as standard with a natural anodised aluminium grille. This can be replaced by one of the following grilles at a surcharge. Please change the two red digits to the left of the red line in the article number to select an alternative grille.

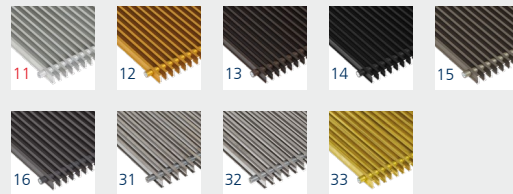

Article key for grille finish (example of art. no.)

0→	14332231	11	13C1	→	Aluminium, natural anodised (standard)
12	→	→	→	→	Aluminium, brass anodised
13	→	→	→	→	Aluminium, bronze anodised
14	→	→	→	→	Aluminium, black anodised
15	→	→	→	→	Aluminium, bronze finish
16	→	→	→	→	Aluminium, coated DB 703
31	→	→	→	→	Stainless steel, natural
32	→	→	→	→	Stainless steel, polished
33	→	→	→	→	Brass, natural

Please change the two red digits to the right of the red line in the article number to select the required convector length.

Article key for trench length (example of art. no.)

HK 320:

0→	1433223111	13	C1	→	Trench length 915 mm
19	→	→	→	→	Trench length 1200 mm
29	→	→	→	→	Trench length 1700 mm
35	→	→	→	→	Trench length 2000 mm
45	→	→	→	→	Trench length 2500 mm
55	→	→	→	→	Trench length 3000 mm

HK 290:

0→	1432926111	14	C1	→	Trench length 950 mm
19	→	→	→	→	Trench length 1200 mm
29	→	→	→	→	Trench length 1700 mm
35	→	→	→	→	Trench length 2000 mm
45	→	→	→	→	Trench length 2500 mm
55	→	→	→	→	Trench length 3000 mm

HK 360:











0→	1433622111	14	C1	→	Trench length 950 mm
19	→	→	→	→	Trench length 1200 mm
22	→	→	→	→	Trench length 1350 mm
32	→	→	→	→	Trench length 1850 mm
40	→	→	→	→	Trench length 2250 mm











# Accessories

Figure	Article	Properties	Suitable for	Art. no.
<b>24 V electromechanical control accessories</b>				
	<b>Clock thermostat type 30456</b>	Clock thermostat 24 V, heating/cooling with 2-pipe system, flush-mounted, continuously variable, with LCD operating menu and integrated timer program, heating/cooling changeover by means of external potential-free contact (low voltage)	Katherm HK, 24 V electromechanical model (not for HK 360)	<b>19600030456</b>
<b>230 V electromechanical control accessories</b>				
	<b>Room thermostat type 30155</b>	Heating/cooling with 2-pipe/4-pipe, surface-mounted, 3-stage, with Off/Manual/Automatic fan changeover, max. two units can be connected heating/cooling changeover by external potential-free contact (low voltage)	Katherm HK 230 V electromechanical model, only in conjunction with 230 V actuator, type 194000146905	<b>19600030155</b>
	<b>Climate controller type 148941</b> (no Modbus)	Climate controller, wall-mounted, with high-quality glass finish and capacitive keys, white, 2.5" LCD display with automatic background lighting, built-in room temperature sensor, password-protected parameter level, optionally: automatic fan or five manually adjustable stages, timer program with three timer channels and four switch-over points, 2x potential-free contacts (input), 1 x 230 V AC contact (input)	Katherm HK 230 V electromechanical model, only in conjunction with 230 V actuator, type 194000146905	<b>196000148941</b>
	<b>Climate controller type 148942</b> (no Modbus)	Climate controller, wall-mounted, with high-quality glass finish and capacitive keys, black, otherwise as art. no. 196000148941	Katherm HK 230 V electromechanical model, only in conjunction with 230 V actuator, type 194000146905	<b>196000148942</b>
	<b>Climate controller type 148943</b> (with Modbus)	Climate controller, wall-mounted, with high-quality glass finish and capacitive keys, white, 2.5" LCD display with automatic background lighting, built-in room temperature sensor, password-protected parameter level, optionally: automatic fan or five manually adjustable stages, timer program with three timer channels and four switch-over points, network connection option via serial interface (Modbus RTU, max. 32 units can be connected per network), 1x potential-free contact (input), 1x 230 V AC contact (input)	Katherm HK 230 V electromechanical model, only in conjunction with 230 V actuator, type 194000146905	<b>196000148943</b>
	<b>Climate controller type 148944</b> (with Modbus)	Climate controller, wall-mounted, with high-quality glass finish and capacitive keys, black, otherwise as art. no. 196000148943	Katherm HK 230 V electromechanical model, only in conjunction with 230 V actuator, type 194000146905	<b>196000148944</b>

[more »](#)

Figure	Article	Properties	Suitable for	Art. no.
<b>KaControl accessories</b>				
	<b>KaController operating unit</b> with one-touch operation	Room control unit, wall-mounted, in high-grade design, plastic housing, colour similar to RAL 9010, large LCD multifunctional display, integrated room temperature sensor, communication interface to Kampmann T-LAN bus system, automatically switching LED backlight, press/turn dial with click stop function, individually adjustable basic display, integrated day, night and week program, password-protected parameter level for C1 control option	All models	<b>196003210001</b>
	<b>KaController operating unit</b> with side function keys	For quick access to fan setting, operating modes, Eco mode, time and timer program, otherwise as art. no. 196003210001	All models	<b>196003210002</b>
	<b>KaController operating unit</b> with one-touch operation	Room control unit for wall mounting, high-quality design, plastic housing, colour similar to RAL 9017, otherwise as art. no. 196003210001	All models	<b>196003210006</b>
	<b>KaControl SEL panel without BACnet</b>	KaControl electronics housed in a surface-mounted wall housing, wired ready-for-use, including KaControl operating unit for the central control of Kampmann products via a serial bus communication (Modbus); for integration of a maximum of 24 units (Modbus subscribers) (optionally with a maximum of 6 BACnet objects in a BACnet/IP network)	All models	<b>196003232122</b>
	<b>KaControl SEL panel with BACnet</b>			<b>196003232123</b>
	<b>Room temperature sensor</b>	For wall mounting, IP30 surface-mounted, white RAL 9010, alternative to the temperature sensor in the KaController	All models	<b>196003250110</b>
	<b>Pipe clip-on sensor</b>	For detecting the temperature of the medium, including strap, 3 m cable, to protect the unit from frost	All models	<b>196003250115</b>
	<b>Serial CANBus card</b>	To increase the number of units in a single-circuit control system	All models	<b>196003260301</b>
	<b>Serial Modbus card</b>	For connection to Modbus networks	All models	<b>196003260101</b>
	<b>Serial KNX card</b>	For integration into KNX-/EIB networks	All models	<b>196003260701</b>
	<b>Serial LON FTT10A card</b>	For integration into LON FTT10A networks	All models	<b>196003260501</b>

more »

Figure	Article	Properties	Suitable for	Art. no.
<b>Connecting accessories</b>				
	<b>Katherm HK valve kit</b>	2-pipe heating/cooling with 1 no. valve body, axial, pre-adjustable, 1/2" connection 1 no. return shut-off valve body, angled, 1/2" connection 1 no. thermoelectric actuator 24 V, supplied loose	All Katherm HK 320/HK 290	<b>194000143211</b>
	<b>Katherm HK valve kit</b>	4-pipe heating/cooling with 2 no. valve body, axial, pre-adjustable, 1/2" connection 1 no. return shut-off valve body, angled, 1/2" connection 1 no. return shut-off valve body, straight, 1/2" connection 2 no. thermoelectric actuators 24 V, supplied loose		<b>194000143411</b>
	<b>Katherm HK valve kit for higher flows</b>	2-pipe heating/cooling with 1 no. valve body, axial, pre-adjustable, 1/2" connection 1 no. return shut-off valve body, angled, 1/2" connection 1 no. thermoelectric actuator 24 V, supplied loose	All Katherm HK 320/HK 290, recommended for higher flow rates above 250 l/h all Katherm HK 360	<b>194000143241</b>
	<b>Katherm HK valve kit for higher flows</b>	4-pipe heating/cooling with 2 no. valve body, axial, pre-adjustable, 1/2" connection 1 no. return shut-off valve body, angled, 1/2" connection 1 no. return shut-off valve body, straight, 1/2" connection 2 no. thermoelectric actuators 24 V, supplied loose		<b>194000143441</b>
	<b>Valve axial, 1/2" connection, pre-adjustable</b>	Low-noise air flow-optimised design with stainless steel spindle and double O-ring seal, max. operating temperature 120 °C, max. operating pressure 10 bar	All Katherm HK 320/HK 290	<b>194000346911</b>
	<b>Valve for higher flow axial, 1/2" connection, pre-adjustable</b>	Whisper-quiet flow-optimised design with maintenance-free spindle seal and double O-ring seal, max. operating temperature 120 °C, max. operating pressure 10 bar	All Katherm HK 320/HK 290, recommended for higher flow rates above 250 l/h all Katherm HK 360	<b>194000346914</b>
<b>Adjustment key</b>				
	<b>Adjustment key</b>	For pre-adjustable valves and valve kits	For valves and valve kits with art. nos. 194000346911, 194000143211, 194000143411	<b>194000346915</b>
	<b>Adjustment kit for higher-flow rate valves</b>	For pre-adjustable valves and valve kits with higher flow rate	For valves and valve kits with art. nos. 194000346914, 194000143241, 194000143441	<b>194000346916</b>

[more »](#)

Figure	Article	Properties	Suitable for	Art. no.
<b>Return valves</b>				
	<b>Return shut-off valve</b> straight, 1/2" connection	Brass, nickel-plated housing, with O-ring seal, max operating temperature 120 °C maximum operating pressure 10 bar	All Kathern HK 320/HK 290	<b>194000145952</b>
	<b>Return shut-off valve</b> angled, 1/2" connection	Brass, nickel-plated housing, with O-ring seal, max operating temperature 120 °C maximum operating pressure 10 bar	All Kathern HK 320/HK 290	<b>194000145953</b>
	<b>Return fitting</b> straight connection 1/2" for higher flow	Brass, nickel-plated housing, with O-ring seal, Max operating temperature 120 °C maximum operating pressure 10 bar	All Kathern HK 360	<b>194000145954</b>
	<b>Return fitting</b> angled connection 1/2" for higher flow	Brass, nickel-plated housing, with O-ring seal, Max operating temperature 120 °C maximum operating pressure 10 bar	All Kathern HK 360	<b>194000145955</b>
<b>Valve actuators</b>				
	<b>Thermoelectric actuator, 24 V</b>	Power uptake approx. 1 W, Connecting cable length approx. 1000 mm, Overall height 58 mm, overall width 49 mm, with valve adapter ring	All valve bodies	<b>194000146906</b>
	<b>Thermoelectric actuator, 230 V</b>	Power uptake approx. 1 W, Connecting cable length approx. 1000 mm, Overall height 58 mm, overall width 49 mm, with valve adapter ring (only in conjunction with room thermostat, type 30155)	All valve bodies, in conjunction with Room thermostat type 30155	<b>194000146905</b>
<b>Other accessories</b>				
	<b>Condensate pump fitting kit</b>	For use with Kathern HK with condensation pump max. head 10 m, max. pumping volume 12 l / h, supply voltage 230 V / 50 Hz (separate mains line required), power consumption 20 W, condensate pressurised line DN 6 mm (hose connection), signal contact for condensate overflow changeover contact, potential-free; switching output 230 V / 8 (4) A	Supplied separately HK 320, height 130 mm HK 360, height 210 mm	<b>194000143813</b>
			Supplied separately HK 290, height 160 mm	<b>194000143815</b>
			Factory-fitted HK 320, height 130 mm HK 360, height 210 mm	<b>194000143814</b>
			Factory-fitted HK 290, height 160 mm	<b>194000143816</b>
	<b>Installation cover</b>	Made of wood to provide protection during installation, factory-fitted, grilles are supplied separately	Trench width 320 mm	<b>194000100320</b>
			Trench width 290 mm	<b>194000100290</b>
			Trench width 360 mm	<b>194000100360</b>

[more »](#)

Figure	Article	Properties	Suitable for	Art. no.
<b>Other accessories</b>				
	<b>Filter for air intake</b>		HK 320, height 130 mm, length 915 mm	<b>143014313013</b>
			HK 320, height 130 mm, length 1200 mm	<b>143014313019</b>
			HK 320, height 130 mm, length 1700 mm	<b>143014313029</b>
			HK 320, height 130 mm, length 2000 mm	<b>143014313035</b>
			HK 320, height 130 mm, length 2500 mm	<b>143014313045</b>
			HK 320, height 130 mm, length 3000 mm	<b>143014313055</b>
			HK 290, height 160 mm, length 950 mm	<b>143014316014</b>
			HK 290, height 160 mm, length 1200 mm	<b>143014316019</b>
			HK 290, height 160 mm, length 1700 mm	<b>143014316029</b>
			HK 290, height 160 mm, length 2000 mm	<b>143014316035</b>
			HK 290, height 160 mm, length 2500 mm	<b>143014316045</b>
			HK 290, height 160 mm, length 3000 mm	<b>143014316055</b>
			HK 360, height 210 mm, length 950 mm	<b>143014321014</b>
			HK 360, height 210 mm, length 1200 mm	<b>143014321019</b>
			HK 360, height 210 mm, length 1350 mm	<b>143014321022</b>
HK 360, height 210 mm, length 1850 mm	<b>143014321032</b>			
HK 360, height 210 mm, length 2250 mm	<b>143014321040</b>			

01 Product information

02 Technical data

03 Design information

04 Controls

05 Ordering information







[kampmanngroup.com/katherm-hk](http://kampmanngroup.com/katherm-hk)

**Kampmann GmbH & Co. KG**  
Friedrich-Ebert-Str. 128 - 130  
49811 Lingen (Ems)  
Germany

**T** +49 591 7108-660  
**F** +49 591 7108-173  
**E** [export@kampmann.de](mailto:export@kampmann.de)  
**W** [Kampmanngroup.com](http://Kampmanngroup.com)

**KAMPMANN**