

THE CATALOGUE

Table of Contents



Alphabetical Table of Contents
General Technical Information

Page 2
Page 4

Small room fans

Individual and central ventilation systems in accordance with DIN 18017-3

Exhaust air systems in accordance with DIN 1946-6

Ventilation systems with heat recovery in accordance with DIN 1946-6

Fans for commercial premises and workplaces

Axial high-performance wall-mounted fans

Axial high-performance duct fans

Radial, semi-radial and diagonal duct fans

Channel fans

Roof fans

Accessories

Table of Contents

				Seite	
<ul style="list-style-type: none"> - Small room fans - Cellar dehumidification - Window installation kits - Duct-mounted fans 				12	
<ul style="list-style-type: none"> - Fire protection systems - Single air extraction system - Centralised air extraction system 				44	
<ul style="list-style-type: none"> - MAICOsmart wireless exhaust air system - Centralised exhaust air units - Outside air openings and overflow element 				88	
<ul style="list-style-type: none"> - Central ventilation units - Ventilation duct systems - Brine earth heat exchanger - Single-room air extraction units 				106	
<ul style="list-style-type: none"> - Axial wall-mounted and window fans for small commercial premises 	<ul style="list-style-type: none"> - Axial ceiling fans for air circulation valves - Axial greenhouse fan for air circulation 				176
<ul style="list-style-type: none"> - Wall-mounted fan - Wall-mounted fans with and without explosion protection 				188	
<ul style="list-style-type: none"> - Duct fans with and without explosion protection 				208	
<ul style="list-style-type: none"> - Semi-centrifugal duct fans with and without explosion protection - Centrifugal duct fans 	<ul style="list-style-type: none"> - External wall fan - Centrifugal flat box - Sound-insulated ventilation boxes - Diagonal fans 				224
<ul style="list-style-type: none"> - Channel fans with and without sound insulation 				256	
<ul style="list-style-type: none"> - Axial roof fans with and without explosion protection - Centrifugal roof fans 				270	
<ul style="list-style-type: none"> - Grilles, shutters, roof cowls - Volumetric flow limiter - Supply and exhaust air 	<ul style="list-style-type: none"> - Sound absorber - Air heater - Air filter - Switches / Controllers / Sensors 				294

A

ABLS	Thermally insulated long pipe elbow	154
AD	Suction nozzle	220, 289
AE	Internal shutter, electric	311
AFR	Flexible aluminium duct	49, 319
AKE	Small room fan	20
AKP	Channel shutter	262, 301
ALD	Outside air opening	104, 105, 308, 309, 310
ALDF	Air filter, replacement	331
ALDS	Storm protection	104, 309
ALDVS	Extension kit	105, 309, 310
AP	Shutter	37, 296
APM HY	Surface-mounted installation kit	348
ARP	Shutter	298
AS	Shutter	297
AVM	Automatic backflow preventer	249, 301
AWB C	Small room fan	15/1, 15/2, 15/3, 15/4
AWV	External wall fan	234
AZP	Air filter, replacement	333
AZV	Exhaust and supply air valve	315

B

B45	45° elbow, drawn	111, 117, 126
B90	90° elbow, drawn	111, 117, 126, 143
BA	Fire protection compensation element	48
BI	Fire protection insulation	48
BK	Shutter, electric	298
BS	Mounting clamp	306

C

Cabel 6 m	Sensor cable for AKE 100	40
Centro	Exhaust air element	82
	Exhaust air element, fire protection	84

D

DAS	Axial fan	204
DF	Roof outlet	306
DHP	Electrical air heater	266, 324
DP	Roofing tile	309
DPK EC	Channel fan	258
DR	Spacing frame	64
DRD EC	Centrifugal roof fan	282
DRH	Electrical air heater	253, 323
DRH R	Electrical air heater with controller	254, 323
DS 3N	3-step switch	77, 342
DS 10	Rotary switch	334
DS 45 RC	Radio switch	171
DS 500	Differential pressure transmitter	349
DSK EC	Sound-insulated channel fan	260
DS RC	Radio switch	40, 77, 98, 149
DSS	5-step switch for TRE...S -2/ TR...S-2 5-step transformer	341
DTL	Power board	254, 267, 346
	Temperature control system	253, 267, 346
DW	Differential pressure controller	252, 266, 350
DZD	Axial roof fan	272
DZD Ex e	Axial roof fan	276
DZF	Axial wall-mounted fan	190
DZQ	Axial wall fan	194
DZQ Ex e	Axial wall fan	200
DZR	Axial duct fan	210

DZR Ex e	Axial duct fan	216
DZS	Axial wall fan	194
DZS Ex e	Axial wall fan	200

E

EAQ	Air quality controller	149, 150, 349
EAT	Temperature control system	345
EAT EC	Pressure and temperature control system	345
EBR / EBR-D	Mounting frame for TFA/TFZ	318
EC	Axial fan	184
ECA 11 E / 15 E	Duct-mounted fan	34
ECA15-EMA16	Spacing frame	39
ECA 100 ipro	Small room fan	16, 92
ECA 120	Small room fan	27
ECA 150 ipro	Small room fan	30, 96
ECA-DR	Spacing frame	39
ECA piano	Small room fan	24
ECO	Wall fan	184
ECR F7	Air filter, replacement	333
ECR G4	Air filter, replacement	333
EDR	Diagonal fan	244
EFR	Centrifugal flat box	236
EHD	Centrifugal roof fan	284
EK	Installation box	315
EKR-2	Sound-insulated ventilation box	246
EL	Flexible cuff	219, 248, 291
ELA	Flexible coupling	220, 292
ELA Ex	Flexible coupling	220, 292
EL Ex	Flexible cuff	219, 291
ELM	Flexible cuff	230
ELM Ex	Flexible cuff	230
ELP	Flexible coupling	262
ELR	Fixing cuff	248
EN	Axial wall-mounted fan	178
ENR	Axial wall-mounted fan	178
ER	Fan insert	66, 94
ER-A	Cover	54
ER-AB	Cover	54
ER-AH	Cover	54
ER-AK	Cover	54
ER-AP	Surface-mounted fan	71
ER-APB	Surface-mounted fan, fire protection	74
ER-AR	Masking frame	64
ER-AS	Air extraction socket	56, 65
ER EC	Fan insert	52
ER GH	Recessed-mounted housing	50
ERH	Electrical air heater	253, 323
ERH R	Electrical air heater with controller	254, 323
ERK	Diagonal fan	242
ERM	Semi-centrifugal duct fan	226
ERM Ex e	Semi-centrifugal duct fan	228
ER-MO	Sponge rubber set	56, 65
ER-MR	Wall frame	64
ER-MS	Installation kit	57
ERR	Centrifugal duct fan	232
ER-UPB	Recessed-mounted housing	62
ER-UPD	Recessed-mounted housing	60
ER-UP/G	Recessed-mounted housing	58
ER-ZR	Second room extraction system	65
ESG	Internal grille	38, 311
E-SM	Enocean plug-in module	151
ESR-2 EC	Sound-insulated ventilation box	238

ESS	5-step switch for TRE...S -2/ TR...S-2 5-step transformer	341
ETL	Temperature control system	253, 346
EV	Axial window fan	182
EVH	Axial window fan	182
EVN	Axial window fan	180
EVR	Axial window fan	182
EW	Brine-air heat exchanger	156
EZD	Axial roof fan	272
EZF	Axial wall-mounted fan	190
EZG	Axial greenhouse fan	186
EZQ	Axial wall fan	194
EZQ Ex e	Axial wall fan	200
EZR	Axial duct fan	210
EZS	Axial wall fan	194
EZS Ex E	Axial wall fan	200

F

FE	Window installation kit	23
	Air filter, replacement	251
FF	Air filter, replacement	207, 327, 330, 331, 332
FFE	Grease filter element for exhaust air	318
FFS	MAICO FFS ventilation duct system, flat	164
FFT	Humidity and temperature sensor	347
FG	Fly screen	296, 303
Fire protection system		46
FL	Channel sensor	254, 267, 346
FR	Room sensor	254, 267, 346
Frame APM HY 230	Surface-mounted frame	348
FS	Step switch, reversing switch	335
FU	Mounting foot	219
FUM	Mounting foot	230
FUR	Mounting foot	248

G

GF	Counter flange	222, 290
GP	Vibration damper	219
GRD	Centrifugal roof fan	80, 280
GS	Counter socket	222, 291

H

HDR / HDR EC	Diagonal fan	240
HS	Main switch, service switch	334
HY	Hygrostat	348

I

IG	Internal grille	312
-----------	-----------------	------------

J

JRE	Control shutter	223, 293, 300
------------	-----------------	----------------------

K

KF	Air filter, replacement	265, 330
KFF	Air filter, replacement	333
KSD-D	Sound insulation set	239
K-SM	KNX plug-in module	151
KSP	Channel sound absorber	264, 322
KW-AL	Outside air wall connection	154, 307
KW-FL	Outgoing air wall connection	155, 307
KWH	Combi-wall connection	155, 308

L

LGA	Internal grille	315
LGR	Internal grille	314
LGZ	Internal grille	315
LH-V2A	Stainless steel cowl	304
LW	Air flow monitor	252, 268, 347
LZP	External grille	264, 305

M

MAICOsmart	Wireless exhaust air system	90
MF	MAICOFlex ventilation duct system, round	158
MFU	Frequency converter	339
MGE	External grille	304
MGR	External grille	304
MK	Shutter, electric	298
MLA	External grille	305
MLK	Door ventilation grille	40, 105, 312
MLZ	External grille	305
MS	Servomotor	223, 263, 293, 300, 302
MT	MAICOTherm ventilation duct system, thermally insulated	152
MV	Motor protection switch	336
MVE	Motor protection switch	336
MVEx	Motor protection switch	337
MVS	PTC thermistor triggering device	336

N

NRS	Follow-up relay	343
NTC	Temperature sensor	126

P

P	Pole-changing switch	335
PF	Air filter, replacement	329, 332
PP 45	Single-room ventilation unit	168

Q

QW	Square wall plate	206
-----------	-------------------	------------

R

REM	Reducer	231
REM Ex	Reducer	231
RF	Air filter, replacement	251, 252, 328
RG	Roof cowls	306
RKP	Channel shutter	263, 302
RLS	Room air control	77, 98, 103, 148, 149, 170, 171, 174, 255, 350
Rod	Fastening rod	185
RS	Shutter, manual	299
RSOF	Flat oval duct sound absorber	321
RSR	Tubular sound absorber	250, 320

S

SB	Sound absorber box	320
SD	Socket sound absorber	288, 322
SDE	Slide-in sound absorber	321
SDS	Roof socket for pitched roofs	287
SF	Air filter, replacement	38, 331, 333
SFR	Flexible steel duct	49
SG	External grille	37, 38, 303
	Protective grille, metal	221, 289, 313

SGK	Protective grille, synthetic material	221, 290, 313
SGM	Protective grille	231, 312
SGM Ex	Protective grille	231, 312
SGR	Protective grille	249, 314
SK	Summer cassette	111
SKD	CO ₂ sensor	349
SO	Roof socket for flat roofs	286
SOK	Roof socket for flat roofs, tiltable	286
SOWT	Roof socket for corrugated and trapezoidal roofs	287
ST	Speed controller	41, 338
ST EC	Potentiometer	337
STS	Speed controller, distribution board	339
STU	Speed controller	41, 338
STW	Speed controller, reversing switch	339
SVR	Plug connector for duct	111, 117, 126, 143
SZ	Intermediate socket	288

T

TB	Disk valve, fire protection	317
TFA	Disk valve, metal	317
TFE	Air filter	250, 251, 327, 328
TFP	Air filter	265, 329
TFZ	Disk valve, metal	317
TH	Thermostat	344
THD	Thermostat	344
THR	Thermostat	343
TK	Disk valve, synthetic material	316
TM	Disk valve, metal	316
TMS	Machine protection relay thermistor	336
TM-V2A	Disk valve, stainless steel	316
TR-2	5-step transformer	340
TRE-2	5-step transformer	340
TRE S-2	5-step transformer, control cabinet	341
TR S-2	5-step transformer, control cabinet	341
TS	Fire protection ceiling barrier	49

U

UPM	Mounting support	56, 64
US	Contactors	252, 268, 337
UWK	Reversing switch	338

V

VH	Extension sleeves	179, 206
VSB	Airstream limiter	310
VZ	Time delay switch	342
VZI	Interval switch	342

W

W	Reversing switch	334
WBV	Disk valve, fire protection	317
WD	Blower nozzle	318, 319
WH	Wall sleeve	39, 179
WHP	Water air heater	269, 326
WP	Reversing switch, pole-changing switch	335
WR	Centralised ventilation unit	128, 145
WRF	Air filter, replacement	332, 333
WRF 20	Replacement heat exchanger ring	333
WRG 35	Single-room ventilation unit	173
WRH	Water air heater	255, 325

WRSK	Summer cassette	147
WS	Centralised ventilation unit	108, 112, 120, 133, 138
WS-BP	Bypass for heat exchanger	118, 144
WS-BWD	Ceiling fixing bracket	118
WS-BWU	Universal fixing bracket	117
WSD	Weather protection roof	247
WSF	Air filter, replacement	119, 127, 144, 147, 332
WS-FVA	Filter locking cover	118
WSG	Air filter, replacement	111, 119, 144, 147, 332
WSG-EG	Replacement filter mat	144, 332
WSG-ES	Push-in frame for air filter	119, 127, 144, 332
WSK	Wall bracket	111
WS-MF	Assembly feet	143
WS-SI	Siphon	144
WS-VH	Preheating register	118, 143
WU	Reversing switch	334

X

XE	Radio receiver	350
XS	Radio switch	350

Z

ZDK	Dark room attachment	179
ZEF	Air filter, replacement	331
ZEG	Centralised exhaust air unit	99, 101
ZF	Air filter, replacement	77, 331, 332, 333
ZF EC	Air filter, replacement	57
ZFF	Air filter	207, 330
ZM	Mounting plate	39
ZP	Additional circuit board	151
ZRF	Air filter, replacement	38, 65, 331
ZS	Timer	343
ZVR	Connection frame	297, 299
ZWVQ	Supply air valve	319

Delivery conditions and terms of the guarantee

- Our general Sales and Delivery Terms are valid.

Special versions

- We cannot accept the return of any equipment which was manufactured to a particular customer specification.

Notes regarding the catalogue

- We cannot be held responsible for mistakes or printing errors and retain the right to make technical modifications without giving prior notice.
- The publication of this catalogue invalidates all previous catalogues.
- All texts, photos and graphic designs used in this catalogue are intellectual property of MAICO, Villingen-Schwenningen, Germany.
- Due to the copyright and the competition law every illegal usage of intellectual property is not allowed.
- All technical details are valid as the time of printing. We reserve the right to make modifications in line with our policies of continuous improvement.

Important notes

- MAICO fans and associated control units comply with DIN VDE regulations within the framework of the Equipment and Product Safety Act.
- Pressure / volumetric flow characteristic curves and electrical data: The measurements are made using test stands that comply with DIN 24163 or ISO 5801.

CE marking

- MAICO fans meet the basic requirements laid down in the EU 2014/35/EU Low Voltage Guidelines, the EU 2014/30/EU Electromagnetic Compatibility Guidelines and the EU Directive VO 327/11.

Electrical connection

- Only qualified electricians are permitted to make the electrical connections.
- The fans must be connected to a permanent electrical installation. This must be equipped with a mains isolation device with contact openings of at least 3 mm at each pole.

Motor protection

- Most fans have an integrated thermal protection switch, which protects the motor against overheating better than would be the case with an overcurrent protection relay. This is particularly significant if the fan is controlled by voltage reduction as in this case, it is not possible to determine the exact level of over current.
- The thermal contacts are located in the motor winding. They open and interrupt the current feed to the fan as soon as the critical temperature is reached.
- Fans with fitted thermal contacts (two cable cores that are connected to the integrated thermal contact, identified in the wiring diagram by TK) must be connected to a motor protection switch in all cases.

Heat recovery

- Heat recovery rate: The relationship between supply and exhaust air enthalpy volumes according to DIN 45635-38:1986-0.
- Degree of heat provision: The relationship between the recovered heat, including the heat that enters the room through electrical equipment with the supply air flow, and the enthalpy difference.

Sound power level

- The sound power levels are measured at the rated voltage.
- L_{WA2} = Housing sound power level of duct fans in dB.
- L_{WA5} = Free inlet sound power level of duct fans in dB.
- L_{WA6} = Free outlet sound power level of duct fans in dB.
- L_{WA7} = Housing and free inlet sound power level of wall-mounted fans in dB.
- L_{WA8} = Housing and free outlet sound power level of wall-mounted fans in dB.

Air volume

- Unless noted elsewhere, all details regarding air volumes relate to the free suction/free blowing status.

Speed controller

- MAICO fans are suitable as standard for speed controllers using variable voltage with a constant frequency, i.e. for operations on transformers or with phase angles. Speed control via frequency converter can be made on request for fans in special version.
- One benefit of the speed control is the clearly perceptible reduction in noise. This makes it particularly well suited for the night-time operation of ventilation and air conditioning systems. The level reduction can be up to:
 - $\Delta L \approx 50 L_g (n/n_0)$ dB.
(n_0 : Nominal speed)
- Example: Halving the speed reduces the noise level by up to 15 dB.
- There can be a **physically induced humming noise** at lower speeds, through the use of phase angle technology. TRE 5-step transformers are therefore used for speed control in rooms requiring quiet fan operations.
- The I_{Max} value is quoted with the fans in the MAICO Main catalogue and on the internet pages for the configuration of speed controllers and transformers.
- Frequency converters can also be used for speed control with the EZ/DZ and DPK EC ranges with the following limit values:
 - 1) $U_{peak} < 1000$ V
 - 2) $du/dt < 500$ V/ μ s
 The frequency converter must be fitted with additional sinus filters if these values are not complied with.
- If controlling speed with frequency converters, the factory must be consulted.

Speed control devices

- One or more fans can be operated with the offered speed control devices, up to the maximum nominal current.

Transformers

Level	1	2	3	4	5
Voltage, single-phase [V]	85 V	115 V	150 V	180 V	230 V
Voltage, three-phase [V]	105 V	150 V	190 V	250 V	400 V

Sound power level of centralised ventilation units with heat recovery

- L_{WA2} = Housing sound power level in dB.
- L_{WA5} = Free inlet sound power level in dB. Sound power level emitted to the free surroundings. Measured at an operating point on the sockets facing the room (exhaust air).
- L_{WA6} = Free outlet sound power level in dB. Sound power level emitted to the free surroundings. Measured at an operating point on the sockets facing the room (supply air).

Sound measurements

- All measurements are made in an anechoic room using free-field conditions. The test equipment complies with DIN EN 60651 class 1.
- The sound power level L_{WA} is the acoustic power rating generated by a given sound source (fan). It is independent of the measuring distance or the room influences.
- The sound power level L_P varies relative to the sound source (fan) and the sound-absorbent properties of the environment.
- A-rated sound pressure level: The sound pressure levels indicated in the technical data apply to free inlet and free outlet wall fans, measured on the suction side. The values refer to free-field conditions with a distance of 1 m and a direction factor $Q = 2$.
- Sound power level L_{WA7} = Housing and free inlet sound power level in dB. For wall-mounted fans, free inlet and free outlet.

Conversion example

- Below you can see how sound power level L_{WA} converts to sound pressure level L_P using the EZQ 30/2 B fan as an example.
- The sound pressure level L_P should be determined for a distance of 5 m, an equivalent room absorption area of 200 m and a directional factor of $Q = 2$.
- Technical data for EZQ 30/2 B:
 - Housing and free outlet sound power level $L_{WA8} = 88$ dB (A).
 - Sound power level difference in accordance with the diagram = 16 dB (A).
 - $L_P = 88$ dB (A) - 16 dB (A) = 72 dB (A).

Determination of sound level difference

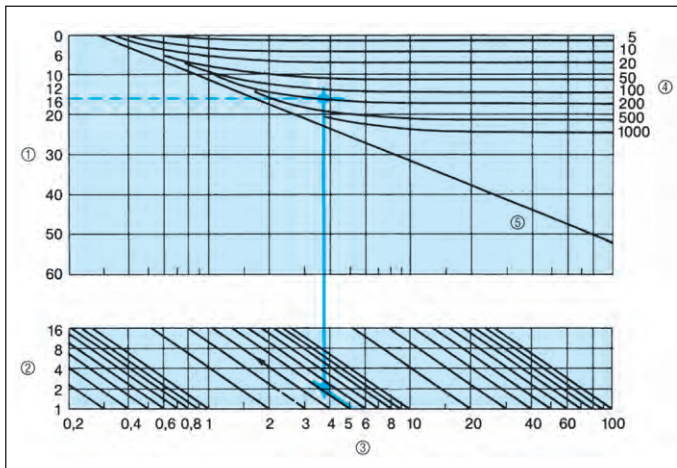

- Sound level difference in dB
- Directional factor Q for sound radiation, dependent on the ventilation installation position.
 $Q=1$: Favourable, e.g. for installing a ceiling fan in the centre of the room. Optional spherical sound propagation on all sides.
 $Q=4$: Less suitable, e.g. for ceiling-mounted fans. See VDI 2081 for the precise determination of Q .
- Distance from the sound source in meters
- Equivalent room absorption area in m^2
- Free field

Sound level at the workplace

- As laid down by the workplace directive, the following levels should not be exceeded over the long-term.

Task	db (A)
Principally mental work	55
Mechanical office work	70
All others (Max. permissible over-level 5 dB (A))	85
Break, sanitary, on-call and rest rooms	55

Difference from sound power level to sound pressure level over distance

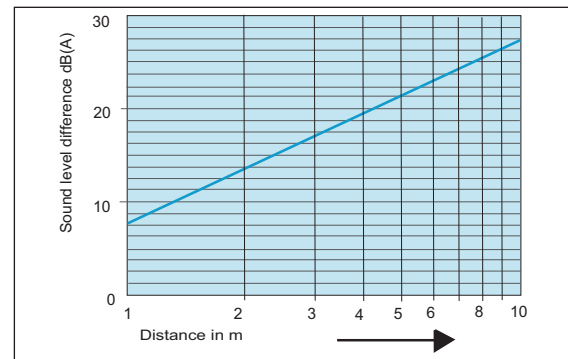

- Example: Fan sound power level = 70 dB (A)
 Sound pressure level at 1 m distance (without obstructions) = 70 dB (A) minus 8 = 62 dB (A)

Addition of several sound sources with the same sound levels

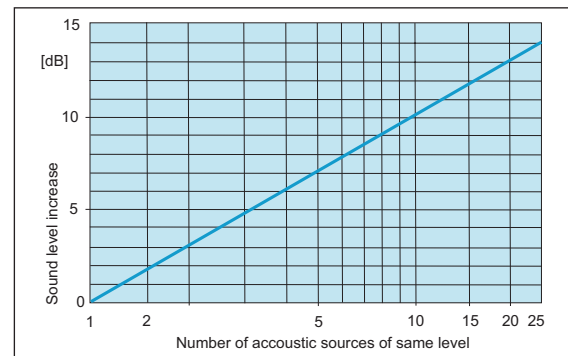

- Example: 10 sound sources at 60 dB (A)
 total volume: 60 dB(A) + 10 dB(A) = 70 dB(A)

Addition of several sound sources with different sound levels

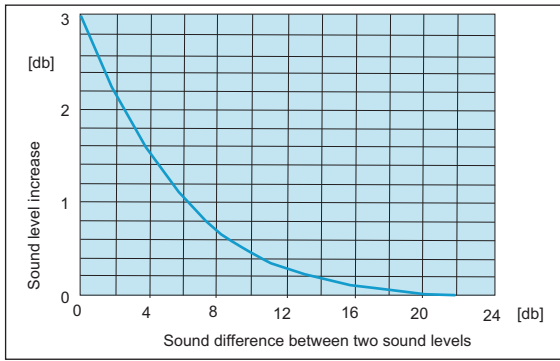

- Example: 2 sound sources at 60 dB (A) and 64 dB (A)
total volume: 64 dB(A) + 1.5 dB(A) = 65.5 dB(A)

Ventilation of apartments in accordance with DIN 1946-6
Information about the following table

- The indicated values serve as a guideline for calculating the ventilation systems. The values that depend on local conditions vary in the case of modified external influences.
- The following tables are derived from DIN 1946-6:2009.
- Indicated air exchange values are just empirical values. They are intended solely to check the volumetric flows calculated from air flow rates or balances.
- The stated standards and guidelines must be taken into account during the planning and execution stages.
- The definitions between the customer and the planner must be taken into account before sizing a ventilation system in accordance with DIN EN 13779 or DIN EN 13779/DIN EN 15251.
- Ventilation measures are necessary in residential units if the volumetric flow for humidity protection $q_{v,ges,NE,FL}$ is bigger than the volumetric flow through infiltration $q_{v,Inf,wirk}$.
- Volumetric flow for humidity protection:
 $q_{v,ges,NE,FL} = f_{WS} \cdot (-0,001 \cdot A_{NE}^2 + 1,15 \cdot A_{NE} + 20)$
- Volumetric flow through infiltration:
 $q_{v,Inf,wirk} = f_{wirk,Komp} \cdot A_{NE} \cdot H_R \cdot n_{50} \cdot (f_{wirk,Lage} \cdot \Delta p / 50)^n$
- Within which:
 - $f_{WS} = 0.3$ for thermal protection high (building with heat insulation at least according to WSchV 95) or 0.4 for thermal protection low
 - $f_{wirk,Komp} = 0.5$ (simplified for the definition of ventilation measures)
 - $f_{wirk,Lage} = 1.0$ (simplified for the definition of ventilation measures)
 - $H_R =$ Room height
 - $n_{50} =$ Measured value or standard value, see table on next page.
 - $\Delta p =$ Configuration differential pressure for single-storey NE (residential units):
areas with low winds = 2 Pa,
areas with high winds = 4 Pa
for multi-storey NE:
areas with low winds = 5 Pa,
areas with high winds = 7 Pa
 - $n =$ Standard value 2/3 or measured value

Emission guide values for sound transfer

- Emission guide values = Guide values for sound pressure level L_p in dB (A).
- External measurement (in accordance with DIN VDI 2058, sheet 1) 0.5 m on the outside, just before the centre of an open window.

External guide values	Time of day	L_p dB(A)
For areas with commercial premises only	-	70
For mixed areas with commercial facilities and residential premises	during the day	60
	at night	45
For areas with exclusively residential premises	during the day	50
	at night	35
For health farms, hospitals, nursing homes	during the day	45
	at night	35

Minimum total outside air volume flows for residential units including infiltration

	Area of the residential unit A_{NE} (in m ²)									
	<=30	50	70	90	110	130	150	170	190	210
Ventilation for humidity protection thermal insulation high $q_{v,ges,NE,FL,H}$ (m ³ /h)	15	25	30	35	40	45	50	55	60	65
Ventilation for humidity protection thermal insulation low $q_{v,ges,NE,FL,G}$ (m ³ /h)	20	30	40	45	55	60	70	75	80	85
Reduced ventilation $q_{v,ges,NE,RL}$ (m ³ /h)	40	55	65	80	95	105	120	130	140	150
Nominal ventilation $q_{v,ges,NE,NL}$ (m ³ /h)	55	75	95	115	135	155	170	185	200	215
Intensive ventilation $q_{v,ges,NE,IL}$ (m ³ /h)	70	100	125	150	175	200	220	245	265	285

Total exhaust air volumetric flows $q_{v,ges,R,ab}$ with fan-assisted ventilation for individual rooms, with or without windows. Including effective infiltration

	Nominal ventilation	Ventilation for humidity protection LF	Reduced ventilation RL	Intensive ventilation IL
Housework room	25	$q_{v,ges,FL}$ $(q_{v,ges,NL} / q_{v,ges,NE,NL})$	$q_{v,ges,RL}$ $(q_{v,ges,NL} / q_{v,ges,NE,NL})$	$q_{v,ges,IL}$ $(q_{v,ges,NL} / q_{v,ges,NE,NL})$
Cellar (hobby)				
corridor (optional)				
WC				
Kitchen, kitchenette	45	$q_{v,ges,NE,FL}$	$q_{v,ges,NE,RL}$	$q_{v,ges,NE,IL}$
Bathroom with or without WC				
Shower				
Sauna / Fitness room	100			

Determination of the exhaust air flow through infiltration

$q_{v,Inf,wirk} = f_{wirk,Komp} \cdot V_{NE} \cdot n_{50} \cdot (\Delta p \cdot f_{wirk,Lage} / 50)^n$

Standard values for the configuration of air exchange at 50 Pa differential pressure

Air exchange configuration $n_{50,conf}$, new construction and renovations in 1/h Category ¹⁾		
A	B	C
1,0 ²⁾	1,5 ^{3), 5), 6)}	2,0 ^{4), 5), 6)}

- 1) The mid-range building stock is described with an $n_{50,conf}$ of 4.5 1/h.
- 2) Fan-assisted ventilation in single and multi-storey residential units
- 3) Free ventilation with new construction in single and multistorey residential units and by renovation in single-storey residential units (e.g. typical in multiple-family units)
- 4) Free ventilation with renovation in multi-storey residential units, e.g. in single family houses (SFH)
- 5) The renovation measure envisages at least a permanently airtight building envelope in line with the recognised rules of technology.
- 6) In the case of a partial renovation of the building envelope, e.g. when exchanging some of the windows, it is recommended that the ventilation measures are laid out in line with the quoted n_{50} values for a complete renovation of the building envelope.

Total outside air volumetric flow

$$q_{v,ges} = q_{v,LIM} + q_{v,Inf,wirk} + q_{v,FE,wirk}$$

Outside air volumetric flow per residential unit, humidity protection Thermal protection high (new building after 1995, complete renovation)

$$q_{v,ges,NE,FL} = 0,3 \cdot q_{v,ges,NE,NL}$$

Thermal protection low (non-renovated old building pre-dating 1995)

$$q_{v,ges,NE,FL} = 0,4 \cdot q_{v,ges,NE,NL}$$

Outside air volumetric flow per residential unit, reduced ventilation

$$q_{v,ges,NE,RL} = 0,7 \cdot q_{v,ges,NE,NL}$$

Outside air volumetric flow per residential unit, nominal ventilation

$$q_{v,ges,NE,NL} = -0,001 \cdot A_{NE}^2 + 1,15 \cdot A_{NE} + 20$$

Outside air volumetric flow per residential unit, intensive ventilation

- $q_{v,ges,NE,IL} = 1,3 \cdot q_{v,ges,NE,NL}$
- $q_{v,ges}$ = Effective total outside air volumetric flow
- $q_{v,LIM}$ = Air volumetric flow through ventilation measures (free or fan-assisted)
- $q_{v,Inf,wirk}$ = Effective air volumetric flow through infiltration
- $q_{v,FE,wirk}$ = Effective air volumetric flow through active window opening (is not used for the specification of ventilation measures in accordance with DIN 1946.6:2009)

Correction factor for the effective infiltration air proportion $f_{wirk,Komp}$

Ventilation system	Free ventilation		Fan-assisted ventilation			
	Cross ventilation	Cross vention and ventilation shaft	Supply / exhaust air system (balanced)	Exhaust air or supply air system		
Apartment type	All residential units			single-storey residential units (MFU)		Multistorey building units (SFH)
				with installation shaft	without	
Outside air openings	0,5	0,6	-	0,65	0,7	0,8
Overcurrent air openings	0,15		0,45	0,15		
Shaft	-	0,35	-			
Fan	-	-	0,45	0,15	0,2	

- $q_{v,ges,FL}$ = Ventilation for humidity protection
- $q_{v,ges,NE,FL}$ = Outside air volumetric flow per residential unit, for ventilation for humidity protection
- $q_{v,ges,RL}$ = Total outside air volumetric flow reduced ventilation
- $q_{v,ges,NE,RL}$ = Outside air volumetric flow per residential unit at reduced ventilation
- $q_{v,ges,NL}$ = Total outside air volumetric flow nominal ventilation
- $q_{v,ges,NE,NL}$ = Outside air volumetric flow per residential unit, for nominal ventilation
- $q_{v,ges,IL}$ = Total outside air volumetric flow intensive ventilation
- $q_{v,ges,NE,IL}$ = Outside air volumetric flow per residential unit, for intensive ventilation
- $q_{v,Inf,wirk}$ = Effective air volumetric flow through infiltration in m^3/h
- $f_{wirk,Komp}$ = Correction factor for the effective infiltration air proportion with one ventilation component in m^3/h , value according the table
- $f_{wirk,Lage}$ = Correction factor for the effective infiltration air proportion dependant on the building location in m^3/h , standard value = 1
- V_{NE} = Residential unit air volume in m^3
- n_{50} = Air exchange in 1/h, standard value $n_{50,conf}$ from table or measured value of the air exchange at 50 Pa
- n = Pressure exponent (value is 0.67 if there is no data from air tightness tests)
- Δ_p = Configuration differential pressure in Pa
 - Single-storey residential unit: low wind = 2 Pa, high wind = 4 Pa; single-storey residential units are typically apartments in multiple-family units
 - Multi-storey residential unit: low wind = 5 Pa high wind = 7 Pa; multi-storey residential units are for example a single-family unit or maisonette apartments.

Ventilation of non-residential buildings in accordance with DIN EN 13779, DIN EN 15251 and workplace guidelines

Volumetric flow calculation through the air exchange value

- Air exchange values (see table below) are empirical values without any particular load caused by harmful substances or contamination.

$$V = V_R \cdot LW/h \text{ [m}^3/\text{h]}$$

VR: Room volumes m³

LW: Air exchange 1/h from the table below

Volumetric flow calculation through the person headcount

$$V = P \cdot A_{RP} \text{ [m}^3/\text{h]}$$

P: Person headcount

A_{RP}: outside air flow per person from the table below

Volumetric flow calculation for heat dissipation

$$V = (Q \cdot 3600) / (p \cdot c_p \cdot \Delta\vartheta) \text{ [m}^3/\text{h]}$$

Q: Heat output to be dissipated kW

c_p: specific air heat kJ/(kg * K)

(Air 20 °C: c_p approx. 1)

Δϑ: Temperature difference between fresh air and heated air K

p: Air density kg/m³ (Air 20 °C, 1013 mbar = 1,2 kg/m³)

(1 kWh = 3600 kJ)

Calculation of the heat power rating for heating the outside air

$$QL = (V \cdot p \cdot c_p \cdot \Delta\vartheta) / 3600 \text{ [m}^3/\text{h]}$$

Ventilation heat / heat power rating kW

V: Volumetric flow m³/h

p: Air density 1,2 kg/m³ (20 °C)

c_p: specific heat kJ/(kg * K)

Δϑ: Temperature difference (K) between ϑ_i room temperature and ϑ_a outside temperature

$$\Delta\vartheta = \vartheta_i - \vartheta_a \text{ [K]}$$

Notes regarding the following table

- The indicated values serve as a guideline for calculating the ventilation systems. The values that depend on local conditions vary in the case of modified external influences.
- Indicated air exchange values are just empirical values. They are intended solely to check the volumetric flows calculated from air flow rates or balances.
- The stated standards and guidelines must be taken into account during the planning and execution stages.
- The definitions between the customer and the planner must be taken into account before sizing a ventilation system in accordance with DIN EN 13779.

Guide values for non-residential buildings and workplaces

	Minimum outside air volumetric flow in accordance with DIN EN 15251 / DN EN 13779 Guidelines for working places		Hourly air exchange	Permissible sound pressure level in accordance with DIN EN 13779	Standards and guidelines	Notes for special requirements
	per person m ³ / h ¹)	per m ² m ³ / (h x m ²) ²⁾				
Garages: Low levels of entering/exiting traffic Other garages	–	6 12	approx. 5	70	VDI 2053 and state garage regulations	Reduction of the pollutant concentration (CO)
Sport and multi-purpose halls: per sportsman per spectator Exhibition halls	60 20 20	–	2 - 3	45 - 50	DIN 18032-1	–
Indoor swimming pools	–	–	3 - 4	45 - 50	VDI 2089	Dehumidification
Waiting rooms	–	–	4 - 7	40 - 45	–	–
Toilets	–	–	5	45	–	–
per urinal	25	–	–	–	–	–
per WC	25	–	–	–	–	–
Changing room	–	–	4 - 8	35	–	Air extraction
Laboratories	–	25	6 - 15	52	VDI 2051 DIN 1946-7	Air extraction Explosion protection Corrosion protection
Dying factories	–	–	5 - 15	55 - 65	–	Explosion protection
Foundries	–	–	8 - 15	55 - 65	VDI 3802	Heat balance Maximum workplace concentration values
Hardening shops	–	–	60 - 100	80	VDI 3802	Maximum workplace concentration values
Welding plants	–	–	20 - 50	70 - 80	VDI 2084	Local air extraction Maximum workplace concentration values
Assembly halls	20 - 50	–	5 - 7	60 - 70	ASR (guidelines for workplaces)	Depending on usage conditions
Workshops	–	–	4 - 8	–	ASR (guidelines for workplaces)	–
Measurement and test rooms	–	–	8 - 10	50 - 65	ASR (guidelines for workplaces)	–
Compressor rooms Computer rooms Transformer rooms	–	–	300 m ³ / h per kWh heat loss	–	–	–
Cafeteria, restaurant	40	–	–	40 - 45	–	–
Non-smoking zone	45	30	–	–	–	–
Smoking zone	90	60	–	–	–	–
Shop, department store	45	11,3	–	40 - 55	–	–
Conference room	45	15	6 - 8	30 - 40	–	–
Classroom	45	18	5 - 7	35	–	–
Open-plan office	45	3,8	–	40	–	–

1) DIN EN 13779, Table A11

2) DIN EN 15251, Standard values for the net floor space per person in acc. with Table B2

Product information as part of EU Regulation VO 327/11 (ErP)

- Product information as part of VO 327/11 is provided on the relevant web pages, main catalogue pages and on the product rating plates.
- Explanations for the terms used are provided below:
- The **best efficiency point (BEP)** is the highest possible efficiency of a fan. The calculation is based on the ratio of electric power consumers to ventilation performance.

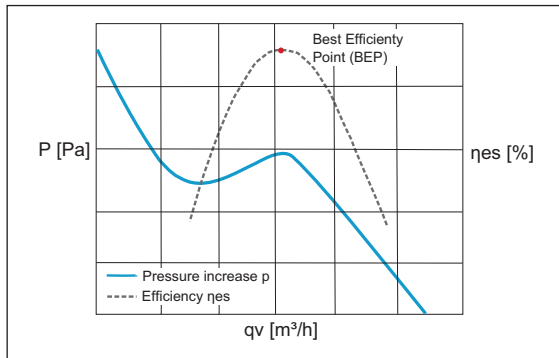

- The following data is collected and published in the best efficiency point: Air volume q_{BEP} , pressure p_{BEP} , speed n_{BEP} , power consumption P_{BEP} , current consumption I_{BEP} and the sound power level L_{WA} .

- The calculated parameter N is used for comparison with the efficiency level specified by the EU. The calculated **efficiency level N** must be greater than or equal to the specified efficiency level.
- The **overall efficiency η** is the fan's calculated static or total efficiency level depending on efficiency category.
- The **measurement category** states how and with what tools the fan's efficiency was measured:
 - A: free inlet and outlet conditions
 - B: free inlet condition and with duct fitted to the outlet
 - C: duct fitted to inlet and free outlet conditions
 - D: ducts fitted to inlet and outlet
- The **efficiency category** describes the measurement process used to determine the energy efficiency. Depending on measurement category the static or total fan pressure is used.
- The **specific ratio** for all ErP-relevant MAICO products is ≈ 1 . It defines the ratio between the back pressure measured at the fan outlet and the back pressure at the fan's best efficiency point (BEP).
- The energy efficiency of all ErP-relevant MAICO products was measured without additional speed regulators. For this reason, an additional VSD (Variable Speed Drive) for reaching the BEP values is not needed with MAICO fans.
- Information about the disassembly and disposal of the fan can be found in the assembly instructions.
- Information about the installation, operation and servicing of the fan can also be found in the assembly instructions.
- When measuring the energy efficiency, only those objects described by the corresponding measurement category were used. Deviations are noted directly next to the affected product.

Explosion protection according to Directive 2014/34/EU (ATEX).

- MAICO EX fans for deployment in areas subject to explosion hazards or for the transporting of gas, vapour and air mixtures at risk of explosion comply with the requirements of the 2014/34/EU (ATEX) Directive.
- The fans have an identifier (see table on the right) and have undergone the CE type-examination.
- MAICO Ex fans are suitable for:
 - Operation in areas subject to explosion hazards.
 - Transporting gas, vapour and air mixtures at risk of explosion.
- The Declaration of Conformity according to the 2014/34/EU Directive confirms the conformity of the product as well as the requirements and the evaluation process as defined in the European Directive.
- The MAICO quality control system is certified in accordance with the 2014/34/EU Directive, Appendix VII.
- The Ex fans fulfil the ignition protection type "e", increased safety, for deployment in Zones 1 and 2, Device group II, Category 2G.
- The mechanical part is produced in accordance with DIN EN 14986.
- Make the connections in line with the relevant regulations.
- All binding specifications can be taken from the motor rating plate. So can the t_E -time for the motor protection switch and the t_A -time for the PTC thermistors in accordance with DIN EN 60079-0 / VDE 0170 / 0171 and DIN EN 60079-10 / VDE 0165-101.
- Speed control is only available with the specially designed types, in conjunction with the MVS 6 or TMS triggering device.

Device groups

- Device group I: Deployment in mining operations and mining equipment that can be at risk from mine gas and combustible dust.
- Device group II: Deployment in all other areas that can be at risk from explosive atmospheres.

Device categories

- 1 - Very high degree of safety
- 2 - High degree of safety
- 3 - Normal degree of safety
- Device group II categories have an additional letter appended - G for gases, D for dust.
- The Ex fans correspond to Device group II, Category 2G (see product-specific information) for operation in Zones 1 and 2 and if installed correctly, fulfil the essential health and safety requirements.

Ignition protection type

- Resource type:
 - „e“ - Increased safety
- As a rule, ignition protection type "e" is added as a sub-group with fan motors with a terminal box.
- Ignition protection type "e" corresponds to Explosion group II.

Zone classification, device groups and categories

Combustible materials	Zone in accordance with DIN EN 60079-10	Explanations	Device groups	Device categories
Gases, vapours, mist	Zone 0	Areas where dangerous, explosive atmospheres are present all the time or for long periods of time.	II	1G
	Zone 1	Areas where it can be assumed that dangerous, explosive atmospheres will occur from time to time.	II	1G or 2G
	Zone 2	Areas where it can be assumed that dangerous, explosive atmospheres occur only infrequently and then only for short periods of time.	II	3G, 2G or 1G

Temperature class, surfaces and ignition temperatures

Temperature class	Highest permitted surface temperature of the equipment	Ignition temperature of the combustible material
T1	450 °C	> 450 °C
T2	300 °C	> 300 °C
T3	200 °C	> 200 °C
T4	135 °C	> 135 °C
T5	100 °C	> 100 °C
T6	85 °C	> 85 °C

Labelling

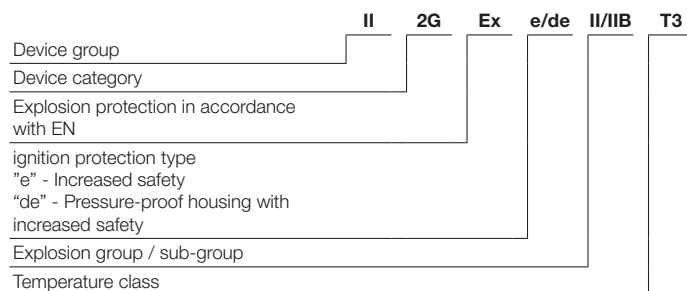

Safety values of combustible gases and vapours

Material designation	Ignition temperature °C	Temperature class			Explosion groups		
Acetaldehyde	155			T4	II A		
Aceton	535	T1			II A		
Acetylene	305		T2				II C
Ethane	545	T1			II A		
Ethylacetane	470	T1			II A		
Ethyl ether	175			T4		II B	
Ethyl aldohol	400		T2			II B	
Ethyl chloride	510	T1			II A		
Ethylene	440		T2			II B	
Ethylene oxide	435 self-disintegration		T2			II B	
Ethyl alcohol	235			T3		II B	
Ammonia	630	T1			II A		
I-Amylacetate	380		T2		II A		
Benzine, gasoline, initial boiling point < 135°	220 to 300			T3	II A		
Special benzine, initial boiling point > 135°C	220 to 300			T3	II A		
Benzol (pure)	555	T1			II A		
N-butane	365		T2		II A		
N-butyl alcohol	325		T2			II B	
Cyclohexanone	430		T2		II A		
1.2 Dichlorethane	440		T2		II A		
Diesel DIN 516010/04.78	220 to 300			T3	II A		
Jet fuel	220 to 300			T3	II A		
Acetic acid	485	T1			II A		
Acetic anhydride	330		T2		II A		
Heating oil EL DIN 51603 Part 1/12.81	220 to 300			T3	II A		
Heating oil L DIN 51603 Part 2/10.76	220 to 300			T3	II A		
Heating oil M and S DIN 51603 Part 2/10.76	220 to 300			T3	II A		
n-Hexane	230			T3	II A		
Carbon monoxide	605	T1			II A		
Methane	595	T1			II A		
Methanol	440		T2		II A		
Methyl chlorid	625	T1			II A		
Naphthalin	540	T1			II A		
Oleic acid	250 self-disintegration			T3		- *	
Phenol	595	T1			II A		
Propane	470	T1			II A		
n-Propyl alcohol	385		T2			II B	
Carbon disulphide	95			T6			II C
Hydrogen sulphide	270			T3		II B	
Town gas (illuminating gas)	560	T1				II B	
Tetralin (Tetrahydronaphtaline)	390		T2		- *		
Toluol	535	T1			II A		
Hydrogen	560	T1					

* Excerpt from the tables "Safety-based parameters", Volume 1 Combustible liquids and gases, Physikalisch-Technische Bundesanstalt (PTB), Braunschweig, from E. Brandes/W. Möller. ISBN 3-89701-745-8

-* The explosion group has not yet been determined for this material.

Small room fans

ECA Fans – Made-to-measure ventilation



Flexible all-rounders for maximum comfort

Whether for domestic bathrooms, hotel rooms, WCs, fitness or utility rooms - there is almost always a suitable ventilation solution with the ECA series from MAICO.

ECA 100 ipro



ECA models

Numerous controller versions – from the standard version through time delay switches up to radio switches

Barrier-free

Barrier-free ventilation with humidity control, light control and motion detector

Simple and individual

The start delay and the overrun time can be set individually with the ECA 100, depending on the model

Super quiet

Meets even the highest demands when it comes to quiet operation

ECA 100 ipro
Design award



Application	Examples from bathroom, WC and cellar		Page 14	
AWB C small room fan	In 3 versions with backflow preventer		Page 14/1	
ECA 100 ipro small room fan	Quiet and economic fan, intelligently programmed with 4 selectable ventilation programmes		Page 16	
AKE 100 small room fan	Automatic cellar dehumidification, intelligently programmed	NEW!		Page 20
FE 100/1 window installation kit for ECA 100 ipro	For installation in windows and thin walls, either with external shutter or protection grille	NEW!		Page 23
ECA piano small room fan	Very quiet and economic fan		Page 24	
ECA 120 small room fan	Proven and powerful fan		Page 27	
ECA 150 ipro small room fan	Intelligently programmed fan combines large air volumes with high pressure		Page 30	
ECA 11 E / ECA 15 E duct-mounted fan	Simple installation on ducts, for numerous application areas		Page 34	
Accessories	From external grilles, through installation material and up to wall sleeves		Page 37	
Planning instructions	Protection areas to be maintained, wall and ceiling installation of small room fans		Page 42	

Application



ECA 100 ipro operating programs

Depending on model, the ECA 100 ipro small room fan has 4 operating programs.

Model	Operating programs
Standard	without operating program: can be operated at two levels with standard double switch
VZC - Model with adjustable start delay and overrun time	All 4 operating programs available
F - Model with light control	All 4 operating programs available
H - Model with two-step humidity control	All 4 operating programs available, when using an optional switch, e.g. light switch
B - Model with motion detector	All 4 operating programs available

ECA 100 ipro - comfort program

In its comfort program, the ECA 100 ipro initially starts up in the low level after an individually adjustable start delay. Only when the room has been left does the fan switch to the high level to

remove all dampness and odours from the bathroom. This overrun time can also be set individually.

Benefits of the comfort program:

When there is someone in the bathroom, there is virtually no operating noise as during this time the ECA 100 ipro is not yet running or is only running in the low level.

The ECA 100 ipro is supplied in the comfort program ex factory.

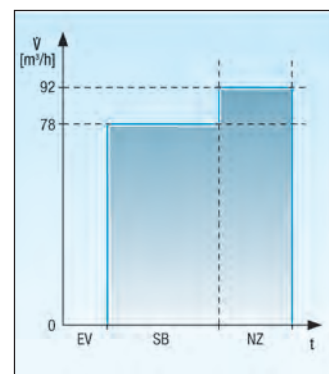

EV - Start delay
SB - Switch operation
NZ - Overrun time

- ① DN 125 roof cowl, reducer to DN 100 provided by the customer
- ② AFR 100 flexible aluminium duct
- ③ Condensate collector, provided by the customer
- ④ ECA 100 ipro small room fan
- ⑤ MLK 45 door ventilation grille

ECA 100 ipro - night program

In its night program, the ECA 100 ipro starts up in the high level after an individually adjustable start delay. This is maintained until the person leaves the room.

Then the fan switches back to the low level. The overrun time in the low level can also be set individually.

Benefits of the night program:

This program is suited to night-time quiet or people with problems sleeping. Since after the

bathroom has been used, virtually no operating noise can be heard outside the room.

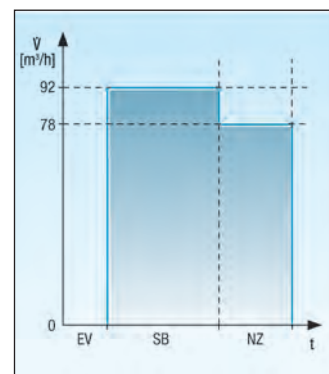

EV - Start delay
SB - Switch operation
NZ - Overrun time

- ① Shutter for air extraction, AP 100
- ② WH 100 wall sleeve
- ③ ECA 100 ipro small room fan
- ④ MLK 45 door ventilation grille

ECA 100 ipro - economy program

- In its economy program, the ECA 100 ipro starts up in the low level after an individually adjustable start delay. This ventilation level is maintained both while the person is present and once the person has left the room. The fan

switches off automatically only once the individually adjustable overrun time has passed.

Benefits of the economy program:

- This program offers permanent comfort coupled with great economy.
- The pleasant ventilation ensures a continuous exchange of air and produces virtually no operating noise.

- The economy program is suited to all rooms only used occasionally, e.g. in a cellar or hobby rooms.

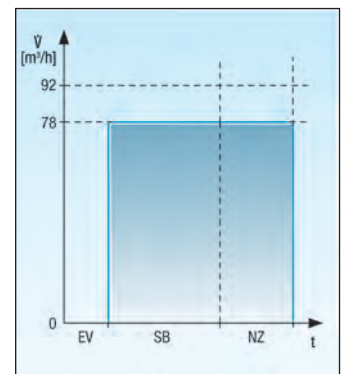
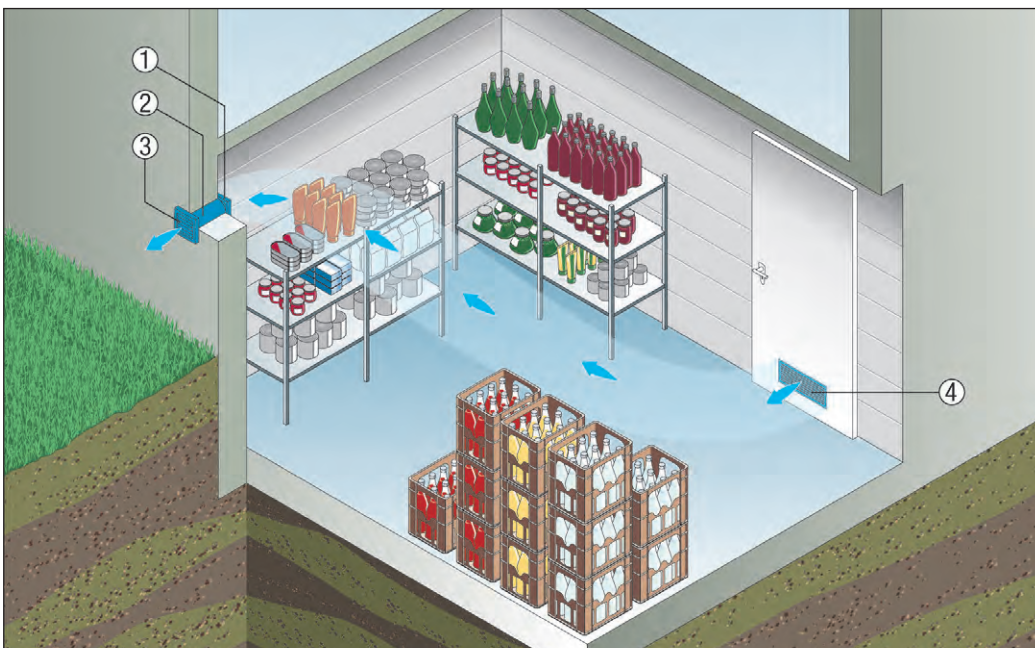

EV - Start delay
SB - Switch operation
NZ - Overrun time

- ① ECA 100 ipro small room fan
- ② WH 100 wall sleeve
- ③ AP 100 shutter
- ④ MLK 45 door ventilation grille

ECA 100 ipro - power program

- The power program is the opposite of the economy program. The ECA 100 ipro starts up in the high level after an individually adjustable start delay. This intensive

ventilation is maintained until the user leaves the room. Yet the fan then continues to run in the high level. As always the overrun time can be set individually.

Benefits of the power program:

- This program ensures a continuous exchange of large volumes of air.
- Unusually high humidity levels and odours are reliably extracted.

- The power program can be used wherever large amounts of air are to be quickly extracted, e.g. in vestibules to saunas.

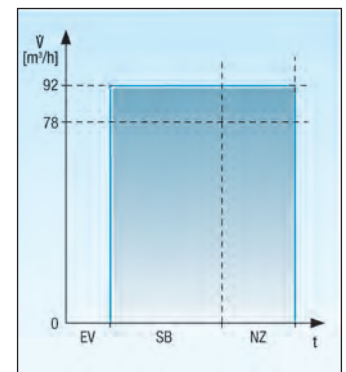

EV - Start delay
SB - Switch operation
NZ - Overrun time

- ① ECA 100 ipro small room fan
- ② WH 100 wall sleeve
- ③ AP 100 shutter
- ④ MLK 45 door ventilation grille



Models

- AWB C: Standard model.
- AWB TC: With overrun time control.
- AWB HC: With humidity control.

Features

- Protection class II.
- Slim design.
- With integrated backflow preventer.
- Speed control optional for standard version.
- Condensation protection for ceiling installation as standard feature.
- Colour: traffic white, similar to RAL 9016.
- Housing made of impact resistant synthetic material.

Motor

- Motor with ball bearings, maintenance-free.
- Suitable for continuous operation.

Mounting information

- Easy and quick cover dismantling.

Electrical connection

- Electrical connection can be either surface- or recessed-mounted.

Condensation drain

- Integrated as standard.

The following models are available:

Standard Standard model

- On/off with light switch or separate switch.
- Speed controllable.
- There can be a physically induced humming noise at lower speeds, through the use of phase angle technology.

TC Model with overrun time control

- On/off with light switch or separate switch.
- The overrun time can be adjusted from approx 3 min. to 25 min.
- Not speed-controllable.

HC Model with humidity control

- Barrier-free product as the fan switches itself on and off automatically.
- Switch-on humidity adjustable from approx. 40 % to approx 90 % relative humidity.

- With an additional switch it is possible to switch manually. The fan then runs on for the set overrun time.
- The overrun time can be adjusted from approx 3 min to 25 min.
- Humidity control has precedence.
- Not speed-controllable.

Technical data

Article	Art. No.	Model	U _{nom} V	f _{nom} Hz	Air flow volume m ³ /h	Power consumption W	I _{max} A	T _{max} at I _{max} °C	Sound pressure level dB(A)	Degree of protection IP	Mains cable mm ²
DN 100											
AWB 100 C	0084.0300	Standard model	230	50/60	70/90 ¹⁾	13	0.09	40	35/36 ²⁾	X4	3 x 1.5
AWB 100 TC	0084.0301	Overrun time control	230	50/60	70/90 ¹⁾	13	0.09	40	35/36 ²⁾	X4	5 x 1.5
AWB 100 HC	0084.0302	Humidity control	230	50/60	70/90 ¹⁾	13	0.09	40	35/36 ²⁾	X4	5 x 1.5
DN 120											
AWB 120 C	0084.0303	Standard model	230	50	145/155 ¹⁾	16	0.1	40	41/42 ²⁾	X4	3 x 1.5
AWB 120 TC	0084.0304	Overrun time control	230	50	145/155 ¹⁾	16	0.1	40	41/42 ²⁾	X4	5 x 1.5
AWB 120 HC	0084.0305	Humidity control	230	50	145/155 ¹⁾	16	0.1	40	41/42 ²⁾	X4	5 x 1.5
DN 150											
AWB 150 C	0084.0306	Standard model	230	50	270/280 ¹⁾	23	0.16	40	45/47 ²⁾	X4	3 x 1.5
AWB 150 TC	0084.0307	Overrun time control	230	50	270/280 ¹⁾	23	0.16	40	45/47 ²⁾	X4	5 x 1.5
AWB 150 HC	0084.0308	Humidity control	230	50	270/280 ¹⁾	23	0.16	40	45/47 ²⁾	X4	5 x 1.5

¹⁾ First value with backflow preventer, second value without backflow preventer

²⁾ Distance 3 m, free-field conditions. First value with backflow preventer, second value without backflow preventer

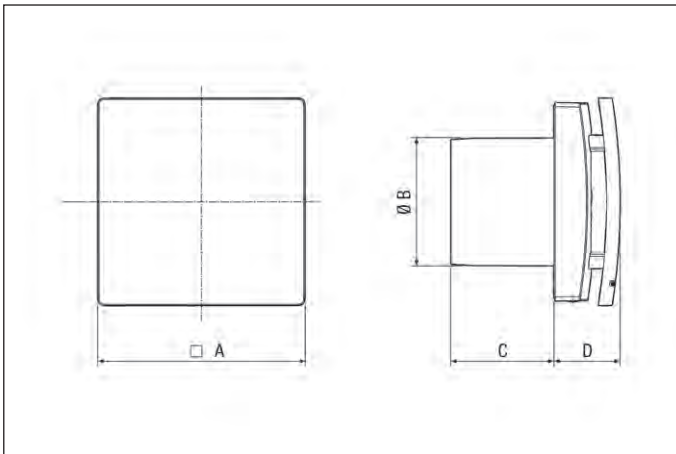
Dimensions [mm]

Nominal size	A	B	C	D
DN 100	160	98	80	38
DN 120	180	119	91	44
DN 150	200	149	105	56

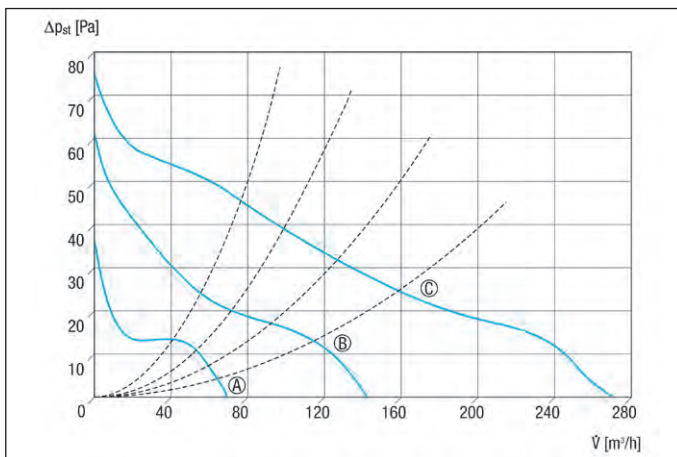
Characteristic curves AWB C with backflow preventer

- Ⓐ AWB C DN 100
- Ⓑ AWB C DN 120
- Ⓒ AWB C DN 150

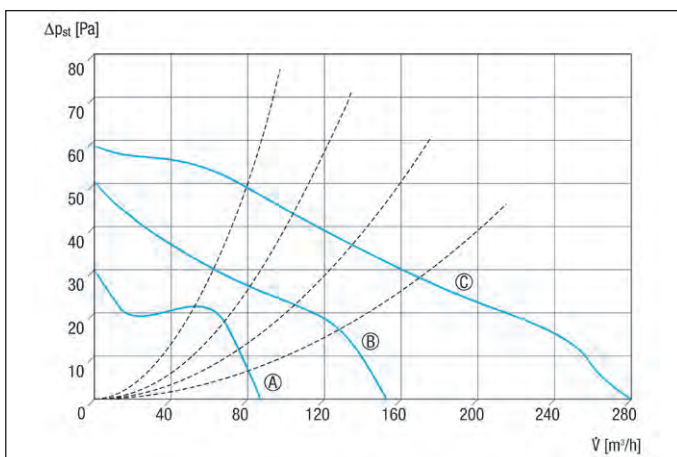
Characteristic curves AWB C without backflow preventer

- Ⓐ AWB C DN 100
- Ⓑ AWB C DN 120
- Ⓒ AWB C DN 150

Important accessories
Shutters

P. 37

Airstream-operated shutters for air extraction, DN 100 and DN 125

AP 100	0059.1058
AP 100 B	0059.0957
AP 120	0059.0950

Dimensions [mm]

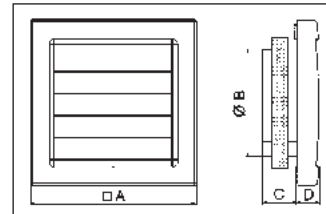

Article	A	B	C	D
AP 100	150	98	29	21
AP 100 B	150	98	29	21
AP 120	172	113	30	23

Shutter

P. 37

Airstream-operated shutter for air extraction, DN 150

AP 150	0059.0952
--------	-----------

Dimensions [mm]

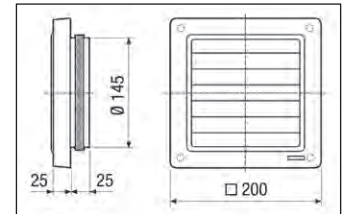

External grilles

P. 37

External grille for ventilation and air extraction, DN 100 and DN 125

SG 100	0059.1054
SG 100 B	0059.0958
SG 120	0059.0951

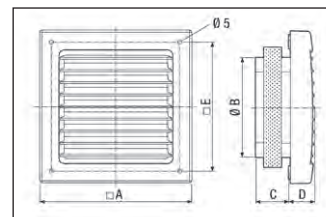
Dimensions [mm]



Article	A	B	C	D	E
SG 100	150	98	29	22.5	130
SG 100 B	150	98	29	22.5	130
SG 120	172	118	30	23	152

External grille

P. 38

External grille for ventilation and air extraction, DN 150

SG 15	0059.0904
-------	-----------

Dimensions [mm]

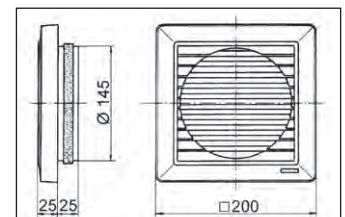

Important accessories

Wall sleeves



P. 39

Synthetic material wall sleeves, for nominal sizes 100 to 150, extendible

WH 100	0059.1030
WH 120	0059.1031
WH 150	0059.1050

Dimensions [mm]

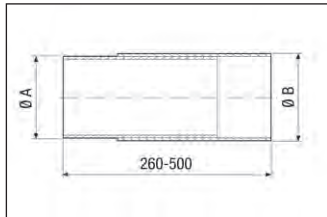

Article	A	B
WH 100	110	114
WH 120	130	135
WH 150	160	168

Mounting plate



P. 39

Mounting plate for installing AWB 100 .. small room fans in square shaft openings

ZM 11	0059.0696
-------	-----------

Dimensions [mm]

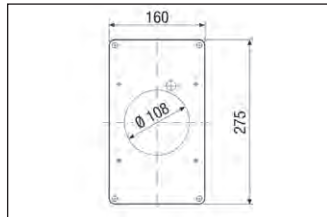

Material thickness 3 mm

Spacing frame



P. 39

Spacer for installing AWB 150 .. small room fans in square wall sleeves

ECA15-EMA16	0092.0251
-------------	-----------

Door ventilation grilles



P. 40

Door ventilation grille for bathroom, WC or kitchen

MLK 30 white	0151.0123
MLK 45 white	0151.0126

Accessories selection table

	AWB 100 C	AWB 100 TC	AWB 100 HC	AWB 120 C	AWB 120 TC	AWB 120 HC	AWB 150 C	AWB 150 TC	AWB 150 HC	see
Mounting plate	ZM 11	ZM 11	ZM 11	–	–	–	–	–	–	P. 39
Spacing frame	–	–	–	–	–	–	ECA15-EMA16	ECA15-EMA16	ECA15-EMA16	P. 39
Shutter	AP 100 AP 100 B	AP 100 AP 100 B	AP 100 AP 100 B	AP 120	AP 120	AP 120	AP 150	AP 150	AP 150	P. 37
External grille	SG 100 SG 100 B	SG 100 SG 100 B	SG 100 SG 100 B	SG 120	SG 120	SG 120	SG 15	SG 15	SG 15	P. 37, P. 38
Wall sleeve	WH 100	WH 100	WH 100	WH 120	WH 120	WH 120	WH 150	WH 150	WH 150	P. 39
Outside air opening	ALD 10 ALD 125 ALD 125 VA ALD 160 ALD 160 VA	ALD 10 ALD 125 ALD 125 VA ALD 160 ALD 160 VA	ALD 10 ALD 125 ALD 125 VA ALD 160 ALD 160 VA	ALD 10 ALD 125 ALD 125 VA ALD 160 ALD 160 VA	ALD 10 ALD 125 ALD 125 VA ALD 160 ALD 160 VA	ALD 10 ALD 125 ALD 125 VA ALD 160 ALD 160 VA	ALD 10 ALD 125 ALD 125 VA ALD 160 ALD 160 VA	ALD 10 ALD 125 ALD 125 VA ALD 160 ALD 160 VA	ALD 10 ALD 125 ALD 125 VA ALD 160 ALD 160 VA	P. 308
Roof outlet	DF 125..*	DF 125..*	DF 125..*	DF 125..**	DF 125..**	DF 125..**	DF 160..**	DF 160..**	DF 160..**	P. 306
Roofing tile	DP 125..*	DP 125..*	DP 125..*	DP 125..**	DP 125..**	DP 125..**	DP 160..**	DP 160..**	DP 160..**	P. 306
Mounting clamp	BS 125*	BS 125*	BS 125*	BS125**	BS125**	BS125**	BS160**	BS160**	BS160**	P. 306
Rain protection grille	RG 125*	RG 125*	RG 125*	RG125**	RG125**	RG125**	RG160**	RG160**	RG160**	P. 306
Door ventilation grille	MLK 30 white MLK 45 white	MLK 30 white MLK 45 white	MLK 30 white MLK 45 white	MLK 30 white MLK 45 white	MLK 30 white MLK 45 white	MLK 30 white MLK 45 white	MLK 30 white MLK 45 white	MLK 30 white MLK 45 white	MLK 30 white MLK 45 white	P. 40
Flexible aluminium duct	AFR 100	AFR 100	AFR 100	AFR 125	AFR 125	AFR 125	AFR 150	AFR 150	AFR 150	P. 319
Step switch	FS 4	–	–	FS 4	–	–	FS 4	–	–	P. 335
Radio switch	XS 1	XS 1	XS 1	XS 1	XS 1	XS 1	XS 1	XS 1	XS 1	P. 350
Radio receiver	XE 1	XE 1	XE 1	XE 1	XE 1	XE 1	XE 1	XE 1	XE 1	P. 350
Speed controller	ST 1 STU 1	–	–	ST 1 STU 1	–	–	ST 1 STU 1	–	–	P. 41
Speed controller, distribution board	STS 2,5	–	–	STS 2,5	–	–	STS 2,5	–	–	P. 339
Time delay switch	VZ 6 VZ 12 VZ 24 C	–	–	VZ 6 VZ 12 VZ 24 C	–	–	VZ 6 VZ 12 VZ 24 C	–	–	P. 342
Interval switch	VZI 10	–	–	VZI 10	–	–	VZI 10	–	–	P. 342
Follow-up relay	NRS 10	–	–	NRS 10	–	–	NRS 10	–	–	P. 343
Hygrostat	HY 230 HY 230 I	–	–	HY 230 HY 230 I	–	–	HY 230 HY 230 I	–	–	P. 348

*Customer must purchase reducer
**Adaptation by the customer needed



Models

- Either as fixed internal grille or K version (ECA 100 ipro K...) with electrically operated internal shutter.

- The following models are available
 - Standard model
 - Adjustable start delay and overrun time
 - Light control
 - Humidity control
 - Motion detector
 - Radio receiver
 - Radio receiver and humidity control
- For more details, see page 18.

Features

- Intelligently programmed small room fan for very demanding requirements.
- 2 performance levels.
- Designer cover conceals the inlet.
- For air extraction.
- VDE-GS symbol, exception: ECA 100 ipro RC / RCH
- VDE mark: ECA 100 RC/RCH.
- IP X5 degree of protection for safety in the bathroom.
- Protection class II.
- Suitable for continuous operation.
- Thermal overload protection.
- Colour: traffic white, similar to RAL 9016.
- Housing made of impact resistant plastic material.

Operating programs

- Can be adjusted using jumper in unit.
 - Comfort program (preset)
 - User present: Level 1
 - Overrun time: Level 2
 - Night program
 - User present: Level 2
 - Overrun time: Level 1
 - Economy program
 - User present: Level 1
 - Overrun time: Level 1
 - Power program
 - User present: Level 2
 - Overrun time: Level 2

- Exception, no operating programs:
 - ECA 100 ipro
 - ECA 100 ipro RC
 - ECA 100 ipro RCH
 - ECA 100 ipro K
- For more details, see page 18.

Motor

- Energy-saving robust motor with ball bearings, maintenance-free.
- Suitable for continuous operation.

Mounting information

- Simplest installation as the cover can be removed with tools.
- Wall and ceiling installation is possible.
- Compatible with ECA predecessor models DN100, because screw holes and cable entry are in the same place.

Electrical connection

- Recessed mounted electrical connection.

Safety instructions

- All ECA 100 ipro units can be used in protection area 1 in accordance with DIN VDE 0100-701.
- For details, please refer to the planning instructions.

Technical data

Article	Art. No.	Model	U _{nom} V	f _{nom} Hz	Air flow volume m ³ /h	Rotating speed 1/min	Power consumption W	I _{max} A	T _{max} at I _{max} °C	Sound pressure level dB(A)	Degree of protection IP	Mains cable mm ²
ECA 100 ipro	0084.0200	Standard model	230	50	78/92	2,100/2,500	6/8	0.06	40	27/32 ¹⁾	X5	3/5 x 1.5
ECA 100 ipro VZC	0084.0201	Adjustable start delay and overrun time	230	50	78/92	2,100/2,500	6/8	0.06	40	27/32 ¹⁾	X5	5 x 1.5
ECA 100 ipro F	0084.0202	Light control	230	50	78/92	2,100/2,500	6/8	0.06	40	27/32 ¹⁾	X5	3/5 x 1.5
ECA 100 ipro H	0084.0203	Humidity control	230	50	78/92	2,100/2,500	6/8	0.06	40	27/32 ¹⁾	X5	3/5 x 1.5
ECA 100 ipro B	0084.0204	Motion detector	230	50	78/92	2,100/2,500	6/8	0.06	40	27/32 ¹⁾	X5	3/5 x 1.5
ECA 100 ipro RC	0084.0210	Radio receiver	230	50	78/92	2,100/2,500	6/8	0.06	40	27/32 ¹⁾	X5	3 x 1.5
ECA 100 ipro RCH	0084.0211	Radio receiver and humidity control	230	50	78/92	2,100/2,500	6/8	0.06	40	27/32 ¹⁾	X5	3 x 1.5
ECA 100 ipro K	0084.0205	Standard model	230	50	78/92	2,100/2,500	10/13	0.08	40	27/32 ¹⁾	X5	3/5 x 1.5
ECA 100 ipro KVZC	0084.0206	Adjustable start delay and overrun time	230	50	78/92	2,100/2,500	10/13	0.08	40	27/32 ¹⁾	X5	5 x 1.5
ECA 100 ipro KF	0084.0207	Light control	230	50	78/92	2,100/2,500	10/13	0.08	40	27/32 ¹⁾	X5	3/5 x 1.5
ECA 100 ipro KH	0084.0208	Humidity control	230	50	78/92	2,100/2,500	10/13	0.08	40	27/32 ¹⁾	X5	3/5 x 1.5
ECA 100 ipro KB	0084.0209	Motion detector	230	50	78/92	2,100/2,500	10/13	0.08	40	27/32 ¹⁾	X5	3/5 x 1.5

¹⁾ Distance 3 m, Free-field conditions



VDE-GS:
ECA 100 pro ...,
exception:
ECA 100 ipro RC/RCH

VDE:
ECA 100 ipro RC/RCH

Dimensions [mm]

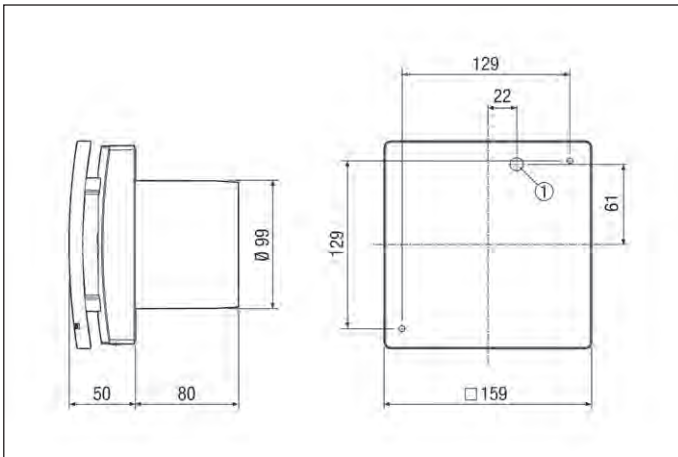

① Cable entry

Characteristic curve

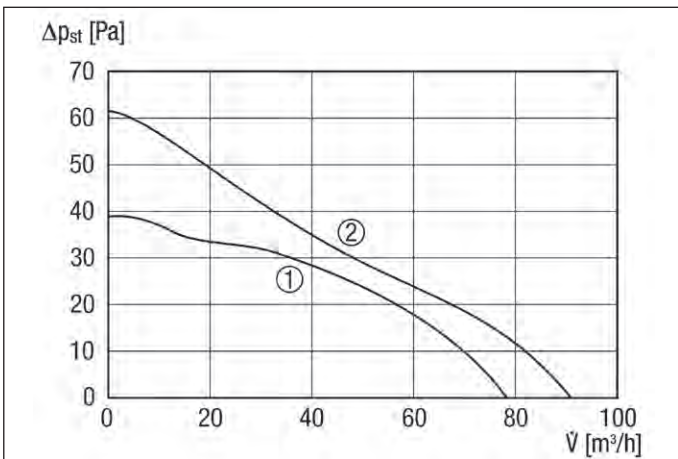

① Performance level 1
② Performance level 2

Important accessories

Shutters



P. 37

Airstream-operated shutters for air extraction, DN 100

AP 100	0059.1058
AP 100 B	0059.0957

Dimensions [mm]

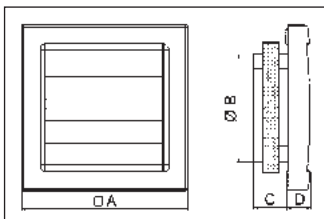

Article	A	B	C	D
AP 100	150	98	29	21
AP 100 B	150	98	29	21

External grilles



P. 37

External grille for ventilation and air extraction, DN 100

SG 100	0059.1054
SG 100 B	0059.0958

Dimensions [mm]

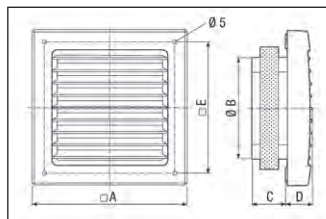

Article	A	B	C	D	E
SG 100	150	98	29	22.5	130
SG 100 B	150	98	29	22.5	130

Important accessories

Wall sleeve



P. 39

Extendable synthetic material wall sleeves, for fans with the nominal size 100

WH 100	0059.1030
--------	-----------

Dimensions [mm]

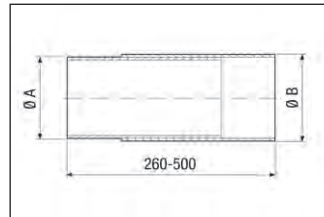

Window installation kits



P. 23

Window installation kit for small room fans ECA 100 ipro. For installation in windows or thin walls. With automatic shutter (AP) or fixed external grille (SG).
FE 100/1 AP 0093.0499
FE 100/1 SG 0093.0500

Dimensions [mm]

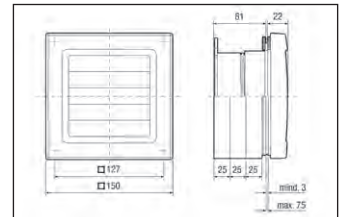

FE 100/1 AP
Window cut-out diameter of 115 up to 120 mm

Article	A	B
WH 100	110	114

Spacing frame



P. 39

Spacing frame for ECA 100 ipro small room fans

ECA-DR	0092.0550
--------	-----------

Dimensions [mm]

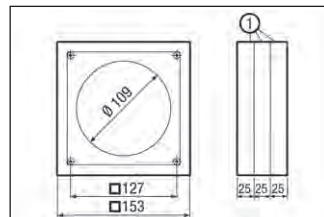

① Spacer elements, detachable

Mounting plate



P. 39

Mounting plate for installing ECA 100 .. small room fans in square shaft openings

ZM 11	0059.0696
-------	-----------

Dimensions [mm]

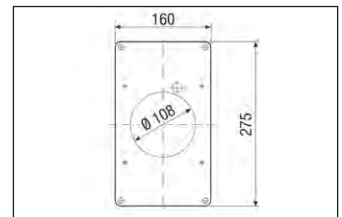

Material thickness 3 mm

Radio switch



P. 40

Radio switch for wirelessly switching ECA ... ipro RC/RCH and ER 100 RC fans

DS RC	0157.0832
-------	-----------

Door ventilation grilles



P. 40

Door ventilation grille for bathroom, WC or kitchen

MLK 30 white	0151.0123
MLK 45 white	0151.0126

The following models are available:

Either as fixed internal grille or K version (ECA 100 ipro K...) with electrically operated internal shutter.

Standard Standard model

- On/off with light switch or separate switch.
- Operation either at level 1 or 2.
- Can be operated at two levels with standard double reversing switch.
- Speed controllable.

- Can only be operated in dark rooms.
- The light control switches on the fan when the minimum light intensity in the room is exceeded, e.g. when a light is switched on.
- Min. 30 lux switch-on intensity (on unit).
- Max. 1.7 lux switch-off intensity (on unit).
- No need to install a switch.
- Start delay can be set to different levels using easily accessible switches: 0/50/90/120 sec.
- Overrun time can be set to different levels using easily accessible switches: 0/8/17/25 min.
- The time set is displayed using LEDs during the setting.
- Not speed-controllable.

VZC Model with adjustable start delay and overrun time

- On/off with light switch or separate switch.
- All 4 operating programs available.
- The sequence of the performance levels depends on which operating program is selected.
- Start delay can be set to different levels using easily accessible switches: 0/50/90/120 sec.
- Overrun time can be set to different levels using easily accessible switches: 0/8/17/25 min.
- The time set is displayed using LEDs during the setting.
- Not speed-controllable.

H Model with automatic humidity control

- Barrier-free product as the fan switches itself on and off via the humidity sensor.
- Switch-on humidity does not have to be set. Fan monitors the room humidity.
- Automatic air extraction depending on room humidity, at level 1 and 2.
- Can be operated without a switch, can also be switched using a separate switch as option.
- Start delay can be set to different levels using easily accessible switches (only if controlled using switch): 0/50/90/120 sec.

F Model with light control

- Barrier-free product as the fan switches itself on and off via the light sensor.
- All 4 operating programs available.
- The sequence of the performance levels depends on which operating program is selected.

- Overrun time can be set to different levels using easily accessible switches: 8/17/25 min. An overrun time of 0 min can only be set for the control using a separate switch.
- The time set is displayed using LEDs during the setting.
- Not speed-controllable.

B Model with motion detector

- Barrier-free product as the fan switches itself on and off via the motion sensor.
- All 4 operating programs available.
- The sequence of the performance levels depends on which operating program is selected.
- Can be operated without a switch, can also be switched using a separate switch as option.
- No start delay.
- Overrun time can be set to different levels using easily accessible switches: 0/8/17/25 min.
- The time set is displayed using LEDs during the setting.
- Effective range of the motion detector: 5 m.
- Horizontal monitoring range of the motion detector: 100°.
- Vertical monitoring range of the motion detector: 82°.
- Not speed-controllable.

RC Model with radio receiver

- With integrated 868 MHz radio receiver.
- On/off via DS RC radio switch or separate RLS RC control.
- The two speeds can be selected either on the radio switch or control.
- Not speed-controllable.
- Can be combined with Wibus smart home system.

RCH Model with radio receiver and humidity control

- With integrated 868 MHz radio receiver and humidity control.
- Switch-on humidity does not have to be set. Fan monitors humidity curve. Automatic air extraction depending on room humidity, at level 1 or 2.
- Can be switched with separate DS RC radio switch or separate RLS RC control.
- The two speeds can be selected either on the radio switch or control.
- Not speed-controllable.
- Can be combined with Wibus smart home system.

Selection help

Article	Article no.	electrically operated internal shutter	On/Off via integrated sensor	On/Off via (light) switch	adjustable start delay (sec.)	adjustable overrun time (min.)	available Steps	step switching via
ECA 100 ipro	0084.0200			X			1 or 2 1 and 2	without step switching; Terminal assignment selects step 1 or 2 Reversing switch (supplied by the customer)
ECA 100 ipro VZC	0084.0201			X	0/50/90/120	0/8/17/25	1 and 2	4 operating programs
ECA 100 ipro F	0084.0202		Light		0/50/90/120	0/8/17/25	1 and 2	4 operating programs
ECA 100 ipro H	0084.0203		Humidity	X	0/50/90/120*	8/17/25**	1 and 2	Humidity curve / 4 operating programs ***
ECA 100 ipro B	0084.0204		Movement	X		0/8/17/25	1 and 2	4 operating programs
ECA 100 ipro RC	0084.0210						1 and 2	Radio switch, room air control
ECA 100 ipro RCH	0084.0211		Humidity				1 and 2	Humidity curve / radio switch, room air control
ECA 100 ipro K	0084.0205	X		X			1 or 2 1 and 2	without step switching; Terminal assignment selects step 1 or 2 Reversing switch (supplied by the customer)
ECA 100 ipro KVZC	0084.0206	X		X	0/50/90/120	0/8/17/25	1 and 2	4 operating programs
ECA 100 ipro KF	0084.0207	X	Light		0/50/90/120	0/8/17/25	1 and 2	4 operating programs
ECA 100 ipro KH	0084.0208	X	Humidity	X	0/50/90/120*	8/17/25**	1 and 2	Humidity curve / 4 operating programs ***
ECA 100 ipro KB	0084.0209	X	Movement	X		0/8/17/25	1 and 2	4 operating programs

* Start delay available when using an optional switch (e.g. light switch)

** Overrun time of 0 min available when using an optional switch (e.g. light switch)

*** 4 operating programs available when using an optional switch (e.g. light switch)

Accessories selection table

	ECA 100 ipro ECA 100 ipro K	ECA 100 ipro VZC ECA 100 ipro KVZC	ECA 100 ipro F ECA 100 ipro KF	ECA 100 ipro H ECA 100 ipro KH	ECA 100 ipro B ECA 100 ipro KB	ECA 100 ipro RC ECA 100 ipro RCH	see
Window installation kit	FE 100/1 AP FE 100/1 SG	FE 100/1 AP FE 100/1 SG	FE 100/1 AP FE 100/1 SG	FE 100/1 AP FE 100/1 SG	FE 100/1 AP FE 100/1 SG	FE 100/1 AP FE 100/1 SG	P. 23
Mounting plate	ZM 11	ZM 11	ZM 11	ZM 11	ZM 11	ZM 11	P. 39
Spacing frame	ECA-DR	ECA-DR	ECA-DR	ECA-DR	ECA-DR	ECA-DR	P. 39
Room air control	-	-	-	-	-	RLS RC	P. 98
Radio switch	-	-	-	-	-	DS RC	P. 40
Shutter	AP 100 AP 100 B	AP 100 AP 100 B	AP 100 AP 100 B	AP 100 AP 100 B	AP 100 AP 100 B	AP 100 AP 100 B	P. 37
External grille	SG 100 SG 100 B	SG 100 SG 100 B	SG 100 SG 100 B	SG 100 SG 100 B	SG 100 SG 100 B	SG 100 SG 100 B	P. 37
Wall sleeve	WH 100	WH 100	WH 100	WH 100	WH 100	WH 100	P. 39
Outside air opening	ALD 10 ALD 125 ALD 125 VA ALD 160 ALD 160 VA	ALD 10 ALD 125 ALD 125 VA ALD 160 ALD 160 VA	ALD 10 ALD 125 ALD 125 VA ALD 160 ALD 160 VA	ALD 10 ALD 125 ALD 125 VA ALD 160 ALD 160 VA	ALD 10 ALD 125 ALD 125 VA ALD 160 ALD 160 VA	ALD 10 ALD 125 ALD 125 VA ALD 160 ALD 160 VA	P. 308
Roof outlet	DF 125..*	DF 125..*	DF 125..*	DF 125..*	DF 125..*	DF 125..*	P. 306
Roofing tile	DP 125..*	DP 125..*	DP 125..*	DP 125..*	DP 125..*	DP 125..*	P. 306
Mounting clamp	BS 125*	BS 125*	BS 125*	BS 125*	BS 125*	BS 125*	P. 306
Rain protection grille	RG 125*	RG 125*	RG 125*	RG 125*	RG 125*	RG 125*	P. 306
Door ventilation grille	MLK 30 white MLK 45 white	MLK 30 white MLK 45 white	MLK 30 white MLK 45 white	MLK 30 white MLK 45 white	MLK 30 white MLK 45 white	MLK 30 white MLK 45 white	P. 40
Flexible aluminium duct	AFR 100	AFR 100	AFR 100	AFR 100	AFR 100	AFR 100	P. 319
Radio switch	XS 1	XS 1	XS 1	XS 1	XS 1	-	P. 350
Radio receiver	XE 1	XE 1	XE 1	XE 1	XE 1	-	P. 350
Speed controller	ST 1 STU 1	-	-	-	-	-	P. 41
Speed controller, distribution board	STS 2,5	-	-	-	-	-	P. 339
Time delay switch	VZ 6 VZ 12 VZ 24 C	-	-	-	-	-	P. 342
Interval switch	VZI 10	-	-	-	-	-	P. 342
Follow-up relay	NRS 10	-	-	-	-	-	P. 343
Hygrostat	HY 230 HY 230 I	HY 230 HY 230 I	HY 230 HY 230 I	-	HY 230 HY 230 I	-	P. 348

*Customer must purchase reducer



Features

- Intelligently programmed automatic cellar dehumidification for the highest demands.
- Integrated automatic humidity control.
- Designer cover conceals the inlet.
- Barrier-free product as the fan switches itself on and off automatically without additional switches.
- Fan monitors the room humidity.
- Frost protection function: Switching off the system at temperatures below 3 °C.
- Can be operated without a switch, can be switched using a separate button as option.
- Status and function displayed using LEDs.
- Not speed-controllable.
- For dehumidification.
- IP X4 degree of protection.
- Protection class II.
- Colour: traffic white, similar to RAL 9016.
- Housing made of impact resistant plastic material.
- Thermal overload protection.

Motor

- Energy-saving robust motor with ball bearings, maintenance-free.
- Suitable for continuous operation.

Mounting instructions

- Simple installation, core drill hole 105 mm / 120 mm when installing with WH 100 wall sleeve accessory.
- Wall and ceiling installation is possible

Electrical connection

- Electrical connection can be either surface- or recessed-mounted.
- Surface installation with ECA-DR spacing frame accessory.

Frost protection

- To prevent the room from cooling down, the AKE 100 has a frost protection function. This means that the fan automatically switches off at outside temperatures of less than 3 °C.

Technical data

Article	Art. No.	U _{nom} V	f _{nom} Hz	Air flow volume m ³ /h	Rotating speed 1/min	Power consumption W	I _{max} A	T _{max} at I _{max} °C	Sound pressure level dB(A)	Degree of protection IP	Mains cable mm ²
AKE 100	0084.0220	230	50	92	2,500	8	0.06	40	32 ¹⁾	X4	5 x 1.5

¹⁾ Distance 3 m, Free-field conditions

Dimensions [mm]

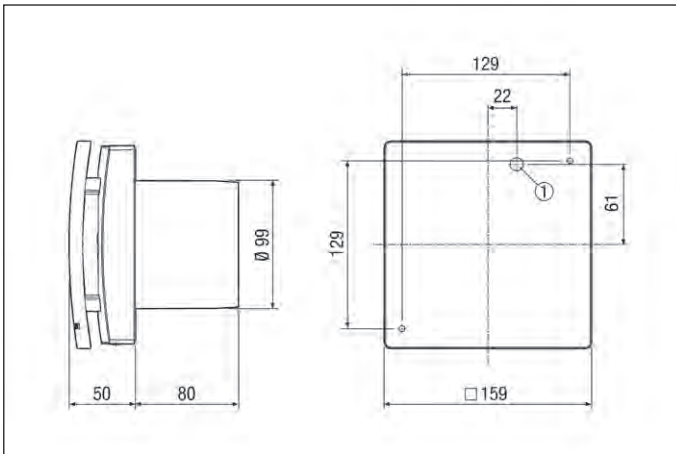

① Cable entry

Dimensions [mm]

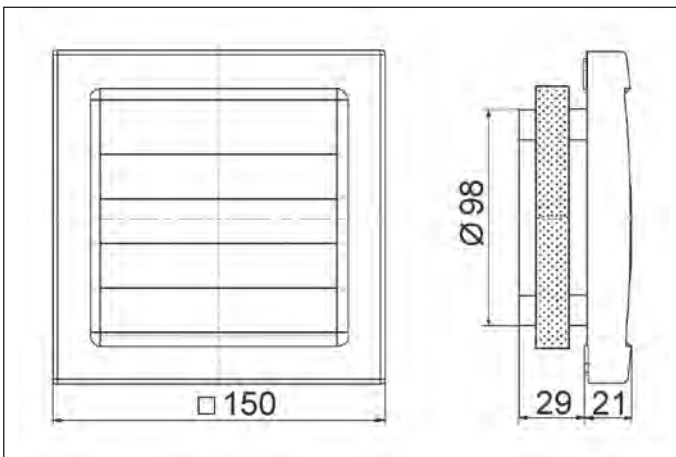

Characteristic curve

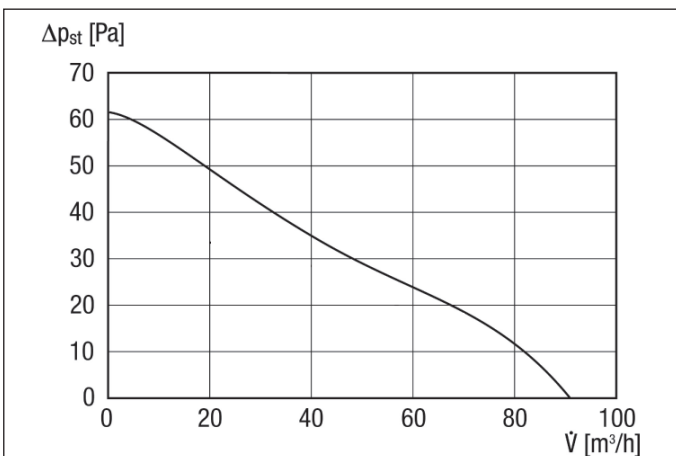

Important accessories

Wall sleeve



P. 39

Extendable synthetic material wall sleeves, for fans with the nominal size 100

WH 100 0059.1030

Dimensions [mm]

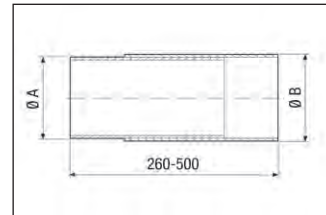

Window installation kit



P. 23

FE 100/1 SG window installation kit with fixed external grille for the fan series ECA 100 ipro. Fan not included in scope of delivery.

FE 100/1 SG 0093.0500

Dimensions [mm]

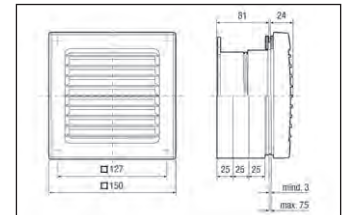

Window cut-out diameter of 115 up to 120 mm

Article	A	B
WH 100	110	114

Duct-mounted fan



P. 34

Duct-mounted fan for installation in folded spiral-seams ducts, DN 100

ECA 11 E 0080.0460

Dimensions [mm]

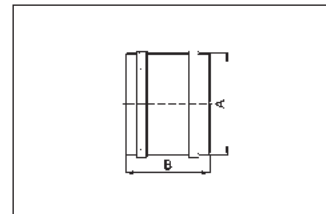

Article	A	B
ECA 11 E	98	109

External grille



P. 37

External grille for ventilation and air extraction, DN 100, white

SG 100 0059.1054

Dimensions [mm]

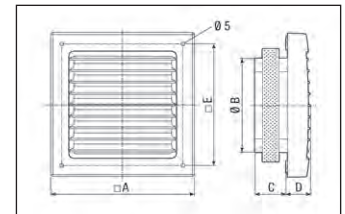

Article	A	B	C	D	E
SG 100	150	98	29	22.5	130

Internal grille



P. 38

Internal grille for ECA duct-mounted fans, nominal size 100

ESG 10/2 0059.0947

Dimensions [mm]

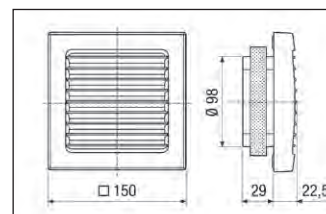

Outside air opening



P. 308

Outside air openings for decentralised domestic ventilation, continuously variable, manual shutters, pure white, DN 100

ALD 10 0152.0054

Dimensions [mm]

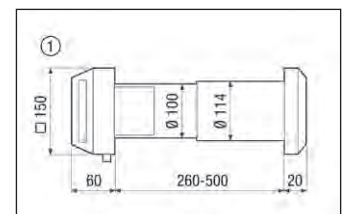

① Inside

Important accessories

Outside air openings



P. 309

Outside air openings for draught-free fresh air supply using outside air

ALD 125 0152.0067
ALD 125 VA 0152.0068

Dimensions [mm]

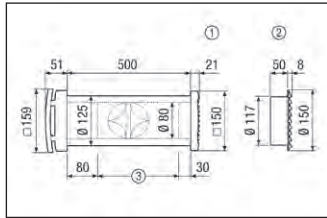

- ① Rectangular plastic external grille
ALD 125
- ② Round stainless steel external grille
ALD 125 VA
- ③ Shorten to wall thickness if required

Spacing frame



P. 39

Spacing frame for ECA 100 ipro small room fans

ECA-DR 0092.0550

Dimensions [mm]

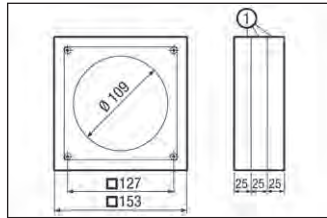

- ① Spacer elements, detachable

Sensor cable for AKE 100



P. 40

Optional sensor connection cable for small room fan AKE 100, if the standard cable (1 m) is too short
cable 6 m 0157.0588

Accessories selection table

	AKE 100	see
Small room fan	ECA 100 ipro	P. 16
Duct-mounted fan	ECA 11 E	P. 34
Window installation kit	FE 100/1 SG	P. 23
Spacing frame	ECA-DR	P. 39
Sensor cable for AKE 100	cable 6 m	P. 40
External grille	SG 100	P. 37
Wall sleeve	WH 100	P. 39
Outside air opening	ALD 10 ALD 125 ALD 125 VA	P. 308
Roof outlet	DF 125..*	P. 306
Roofing tile	DP 125..*	P. 306
Mounting clamp	BS 125*	P. 306
Rain protection grille	RG 125*	P. 306
Internal shutter, electric	AE 10	P. 311
Internal grille	ESG 10/2	P. 38

*Customer must purchase reducer

FE 100/1 window installation kit for ECA 100 ipro

Fan not included in scope of delivery.

Models

- FE 100/1 AP: consisting of AP external shutter, threaded connector, 3 spacing frames, 2 sealing rings.
- FE 100/1 SG: consisting of SG protective grille, threaded connector, 3 spacing frames, 2 sealing rings.

Features

- For installation in windows and thin walls.
- Colour: traffic white, similar to RAL 9016.
- Housing made of impact resistant plastic material.
- Scope of delivery: AP shutter and/or SG external grille, 3 x spacing frames, 2 x sealing rings, threaded connector, 3 x screws for fastening fan, tension relief bar with 2 x screws, cable grommet, operating instructions.

Mounting information

- Easy assembly in window cut-out by adaptor which can be screwed into the threaded connector.
- Pane thickness at least 3 mm, pane spacing up to 75 mm.
- Window cut-out of 115 up to 120 mm.
- Not suited for installation in double-glazed windows that can be swung open.

Electrical connection

- On terminal block in housing of ECA 100 ipro...

Article	Art. No.
FE 100/1 AP	0093.0499
FE 100/1 SG	0093.0500

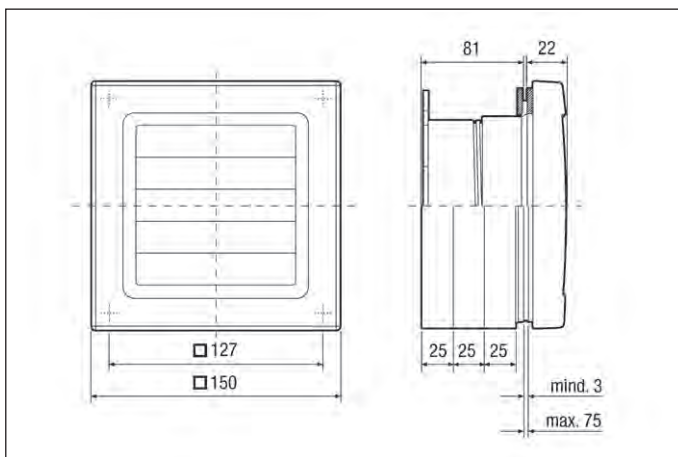
Dimensions [mm] FE 100/1 AP

Window cut-out diameter of 115 up to 120 mm

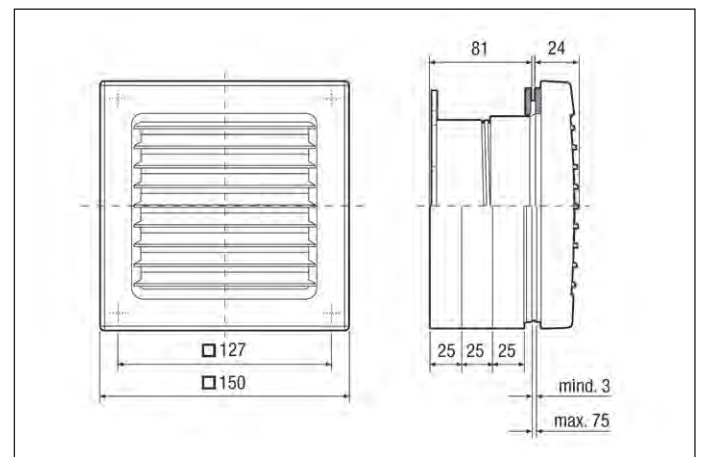
Dimensions [mm] FE 100/1 SG

Window cut-out diameter of 115 up to 120 mm



Features

- Particularly quiet, thanks to the innovative piano impeller.
- Cover can be removed without tools for cleaning.
- Compatible with ECA 100 ipro and ECA predecessor models DN 100, same position for screw holes and cable entry.
- IP X4 degree of protection for safety in the bathroom.
- Protection class II.
- Integrated springless backflow preventer, durable and robust.
- Colour: traffic white, similar to RAL 9016.
- Suitable for DN 100 duct.
- Housing made of impact resistant plastic material.
- Thermal overload protection.

Motor

- Robust motor with ball bearings, maintenance-free.
- Suitable for continuous operation.

Mounting information

- Simplest installation as the cover can be removed without tools.
- Wall and ceiling installation is possible, hole needed in cover for ceiling installation.

Electrical connection

- Recessed mounted electrical connection.

Safety instructions

- All ECA piano units can be used in protection area 2 in accordance with DIN VDE 0100-701.
- For details, please refer to the planning instructions.

The following models are available:

Standard Standard model

- On/off with light switch or separate switch.
- With VDE-GS symbol.
- Speed controllable.
- There can be a physically induced humming noise at lower speeds, through the use of phase angle technology.

TC Model with adjustable overrun time

- On/off with light switch or separate switch.
- With VDE symbol.
- The overrun time can be adjusted from approx 3 min to 25 min.
- Single speed only.

H Humidity control model with adjustable overrun

- Barrier-free product as the fan switches itself on and off automatically.
- With VDE symbol.
- Switch-on humidity adjustable from approx. 50 % to approx 90 % relative humidity.

- With an additional switch it is possible to switch manually. The fan then runs on for the set overrun time.
- The overrun time can be adjusted from approx 0.5 min to 18 min.
- Humidity control has precedence.
- Not speed-controllable.

Technical data

Article	Art. No.	Model	U _{nom} V	f _{nom} Hz	Air flow volume m ³ /h	Rotating speed 1/min	Power consumption W	I _{max} A	T _{max} at I _{max} °C	Sound pressure level dB(A)	Degree of protection IP	Mains cable mm ²
ECA piano Standard	0084.0080	Standard model	230	50/60	80	2,400	8	0.06	40	26 ¹⁾	X4	3 x 1.5
ECA piano TC	0084.0081	Adjustable overrun	230	50/60	80	2,400	8	0.06	40	26 ¹⁾	X4	5 x 1.5
ECA piano H	0084.0082	Humidity control with adjustable overrun	230	50/60	80	2,400	8	0.06	40	26 ¹⁾	X4	3/5 x 1.5

¹⁾ Distance 3 m, Free-field conditions



VDE-GS:
Standard model



VDE:
TC and H model

Dimensions [mm]

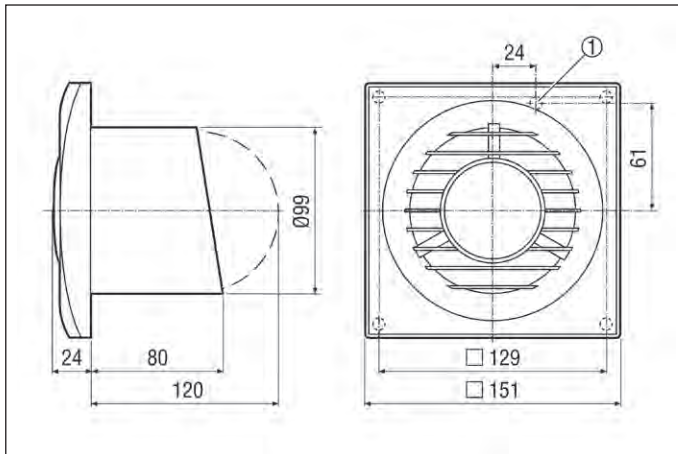

① Cable entry

Characteristic curve

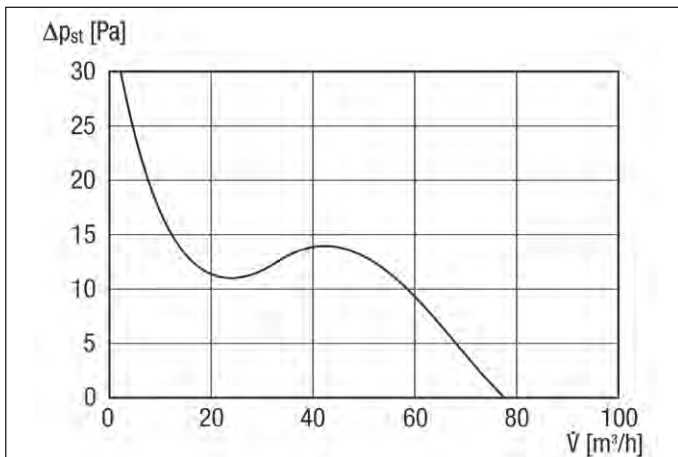

Important accessories

Shutters



P. 37

Airstream-operated shutters for air extraction, DN 100

AP 100	0059.1058
AP 100 B	0059.0957

Dimensions [mm]

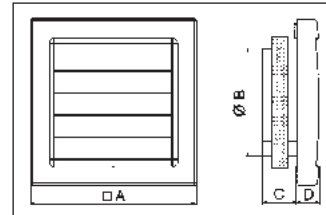

External grilles



P. 37

External grille for ventilation and air extraction, DN 100

SG 100	0059.1054
SG 100 B	0059.0958

Dimensions [mm]

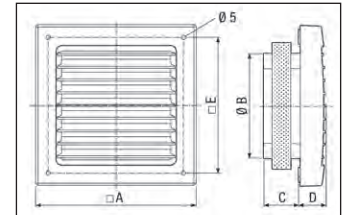

Article	A	B	C	D
AP 100	150	98	29	21
AP 100 B	150	98	29	21

Article	A	B	C	D	E
SG 100	150	98	29	22.5	130
SG 100 B	150	98	29	22.5	130

Wall sleeve



P. 39

Extendable synthetic material wall sleeves, for fans with the nominal size 100

WH 100	0059.1030
--------	-----------

Dimensions [mm]

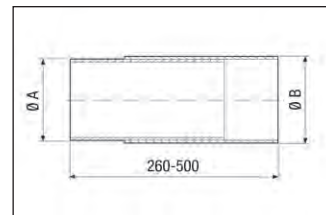

Article	A	B
WH 100	110	114

Mounting plate



P. 39

Mounting plate for installing ECA 100 .. small room fans in square shaft openings

ZM 11	0059.0696
-------	-----------

Dimensions [mm]

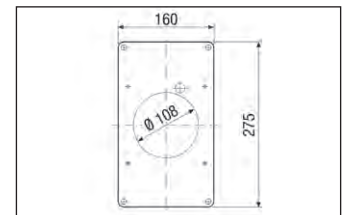

Material thickness 3 mm

Door ventilation grilles



P. 40

Door ventilation grille for bathroom, WC or kitchen

MLK 30 white	0151.0123
MLK 45 white	0151.0126

Accessories selection table

	ECA piano Standard	ECA piano TC	ECA piano H	see
Mounting plate	ZM 11	ZM 11	ZM 11	P. 39
Shutter	AP 100 AP 100 B	AP 100 AP 100 B	AP 100 AP 100 B	P. 37
External grille	SG 100 SG 100 B	SG 100 SG 100 B	SG 100 SG 100 B	P. 37
Wall sleeve	WH 100	WH 100	WH 100	P. 39
Outside air opening	ALD 10 ALD 125 ALD 125 VA ALD 160 ALD 160 VA	ALD 10 ALD 125 ALD 125 VA ALD 160 ALD 160 VA	ALD 10 ALD 125 ALD 125 VA ALD 160 ALD 160 VA	P. 308
Roof outlet	DF 125.*	DF 125.*	DF 125.*	P. 306
Roofing tile	DP 125.*	DP 125.*	DP 125.*	P. 306
Mounting clamp	BS 125*	BS 125*	BS 125*	P. 306
Rain protection grille	RG 125*	RG 125*	RG 125*	P. 306
Door ventilation grille	MLK 30 white MLK 45 white	MLK 30 white MLK 45 white	MLK 30 white MLK 45 white	P. 40
Flexible aluminium duct	AFR 100	AFR 100	AFR 100	P. 319
Radio switch	XS 1	XS 1	XS 1	P. 350
Radio receiver	XE 1	XE 1	XE 1	P. 350
Speed controller	ST 1 STU 1	–	–	P. 41
Speed controller, distribution board	STS 2,5	–	–	P. 339
Time delay switch	VZ 6 VZ 12 VZ 24 C	–	–	P. 342
Interval switch	VZI 10	–	–	P. 342
Follow-up relay	NRS 10	–	–	P. 343
Hygostat	HY 230 HY 230 I	HY 230 HY 230 I	–	P. 348

*Customer must purchase reducer

Models

- Either as fixed internal grille or K-Version (ECA 120 K.) with electrically operated internal shutter.

Features

- High air volume in spite of compact size.
- Combines large air volumes with pressure intensity.
- Thermal overload protection.
- Housing made of impact resistant plastic material.
- Protection class II.
- With VDE-GS symbol, exception: ECA 120 24 V.
- With protective seals to stop ingress of condensation for ceiling installations.
- Optional speed control for standard ECA fan models.
- Colour: traffic white, similar to RAL 9016.

Motor

- Robust motor with ball bearings, maintenance-free.
- Suitable for continuous operation.

Mounting instructions

- Easy and quick cover dismantling.
- The fan can be fastened quickly in the duct by the two spring-clamps.

Electrical connection

- Electrical connection can be either surface- or recessed-mounted.

Safety instructions

- ECA 120 units with IP 45 degree of protection can be used in protection area 1 in accordance with DIN VDE 0100-701.
- For details, please refer to the planning instructions.

The following models are available:
Standard model

- Speed controllable.
- There can be a physically induced humming noise at lower speeds, through the use of phase angle technology.

VZ Model with time delay switch

- Start delay approx. 50 sec.
- Overrun time approx. 6 min.
- Not speed-controllable.

F Model with light control

- Barrier-free product as the fan switches itself on and off automatically.
- The light control switches on the fan when the minimum light intensity in the room is exceeded, e.g. when a light is switched on.
- Min. 30 lux switch-on intensity (on unit).
- Max. 0.3 lux switch-off intensity (on unit).
- No need to install a switch.
- Start delay approx. 50 sec.
- Overrun time approx. 6 min.
- Not speed-controllable.

P Model with pull-cord switch.

- With pull-cord switch and pull cord.
- Not speed-controllable.

24 V Model with safety extra-low voltage (SELV)

- Rated voltage 24 V, 50 Hz.
- Only use with permitted safety isolating transformer (provided by the customer, 230 V/24 V).
- Can be combined with time delay switch VZ 6, VZ 12 or VZ 24 C (see accessories). Install the time delay switch between switch (230 V) and input side of safety transformer.
- Not speed-controllable.

Technical data

Article	Art. No.	Model	U_{nom}	f_{nom}	Air flow volume m^3/h	Rotating speed $1/min$	Power consumption W	I_{max} A	T_{max} at I_{max} $^{\circ}C$	Sound pressure level $dB(A)$	Degree of protection IP	Mains cable mm^2
			V	Hz								
ECA 120	0084.0006	Standard model	230	50/60	170	2,600	19	0.14	40	42 ¹⁾	45	3 x 1.5
ECA 120 VZ	0084.0007	Time delay switch	230	50/60	170	2,600	19	0.14	40	42 ¹⁾	45	5 x 1.5
ECA 120 F	0084.0008	Light control	230	50/60	170	2,600	19	0.14	40	42 ¹⁾	45	3 x 1.5
ECA 120 P	0084.0034	Pull-cord switch	230	50/60	170	2,600	19	0.14	40	42 ¹⁾	23	3 x 1.5
ECA 120 24 V	0084.0019	Safety extra-low voltage (SELV)	24	50/60	170	2,600	19	1.2	40	42 ¹⁾	45	3 x 1.5
ECA 120 K	0084.0009	Standard model	230	50/60	180	2,600	19	0.14	40	36 ¹⁾	34	3 x 1.5
ECA 120 KVZ	0084.0010	Time delay switch	230	50/60	180	2,600	19	0.14	40	36 ¹⁾	34	5 x 1.5
ECA 120 KF	0084.0011	Light control	230	50/60	180	2,600	19	0.14	40	36 ¹⁾	34	3 x 1.5
ECA 120 KP	0084.0035	Pull-cord switch	230	50/60	180	2,600	19	0.14	40	36 ¹⁾	23	3 x 1.5

¹⁾ Distance 3 m, Free-field conditions



VDE-GS: ECA 120 ...,
exception:
ECA 120 24 V

Dimensions [mm]

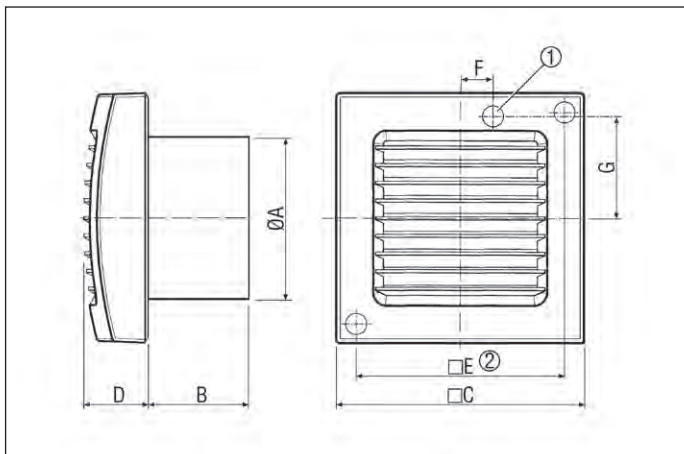

① Cable entry

Article	A	B	C	D	E	F	G
ECA 120	118.5	75	171	39	152	40	71
ECA 120 K	118.5	75	171	36	152	40	71

Characteristic curve

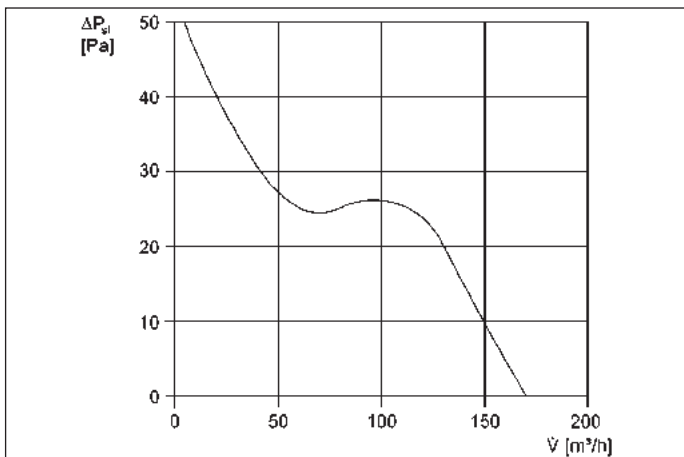

V = 230 or 24 V
 f = 50 Hz
 n = 2600 min⁻¹

Important accessories

Shutter



P. 37

Airstream-operated shutter for air extraction, DN 120

AP 120 0059.0950

Dimensions [mm]

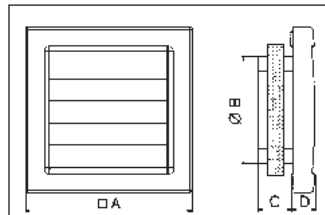

Article	A	B	C	D
AP 120	172	113	30	23

External grille



P. 37

External grille for ventilation and air extraction, DN 120

SG 120 0059.0951

Dimensions [mm]

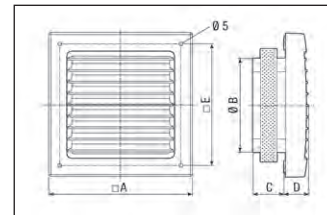

Article	A	B	C	D	E
SG 120	172	118	30	23	152

Wall sleeve



P. 39

Extendable synthetic material wall sleeves, for fans with the nominal size 120

WH 120 0059.1031

Dimensions [mm]

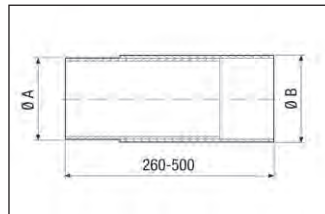

Article	A	B
WH 120	130	135

Door ventilation grilles



P. 40

Door ventilation grille for bathroom, WC or kitchen

MLK 30 white 0151.0123
 MLK 45 white 0151.0126

Accessories selection table

	ECA 120	ECA 120 VZ	ECA 120 F	ECA 120 P	ECA 120 24 V	ECA 120 K	ECA 120 KVZ	ECA 120 KF	ECA 120 KP	see
Shutter	AP 120	AP 120	AP 120	AP 120	AP 120	AP 120	AP 120	AP 120	AP 120	P. 37
External grille	SG 120	SG 120	SG 120	SG 120	SG 120	SG 120	SG 120	SG 120	SG 120	P. 37
Wall sleeve	WH 120	WH 120	WH 120	WH 120	WH 120	WH 120	WH 120	WH 120	WH 120	P. 39
Outside air opening	ALD 10 ALD 125 ALD 125 VA ALD 160 ALD 160 VA	ALD 10 ALD 125 ALD 125 VA ALD 160 ALD 160 VA	ALD 10 ALD 125 ALD 125 VA ALD 160 ALD 160 VA	ALD 10 ALD 125 ALD 125 VA ALD 160 ALD 160 VA	ALD 10 ALD 125 ALD 125 VA ALD 160 ALD 160 VA	ALD 10 ALD 125 ALD 125 VA ALD 160 ALD 160 VA	ALD 10 ALD 125 ALD 125 VA ALD 160 ALD 160 VA	ALD 10 ALD 125 ALD 125 VA ALD 160 ALD 160 VA	ALD 10 ALD 125 ALD 125 VA ALD 160 ALD 160 VA	P. 308
Roof outlet	DF 125..*	DF 125..*	DF 125..*	DF 125..*	DF 125..*	DF 125..*	DF 125..*	DF 125..*	DF 125..*	P. 306
Roofing tile	DP 125..*	DP 125..*	DP 125..*	DP 125..*	DP 125..*	DP 125..*	DP 125..*	DP 125..*	DP 125..*	P. 306
Mounting clamp	BS 125*	BS 125*	BS 125*	BS 125*	BS 125*	BS 125*	BS 125*	BS 125*	BS 125*	P. 306
Rain protection grille	RG 125*	RG 125*	RG 125*	RG 125*	RG 125*	RG 125*	RG 125*	RG 125*	RG 125*	P. 306
Door ventilation grille	MLK 30 white MLK 45 white	MLK 30 white MLK 45 white	MLK 30 white MLK 45 white	MLK 30 white MLK 45 white	MLK 30 white MLK 45 white	MLK 30 white MLK 45 white	MLK 30 white MLK 45 white	MLK 30 white MLK 45 white	MLK 30 white MLK 45 white	P. 40
Flexible aluminium duct	AFR 125	AFR 125	AFR 125	AFR 125	AFR 125	AFR 125	AFR 125	AFR 125	AFR 125	P. 319
Step switch	FS 4	-	-	-	-	FS 4	-	-	-	P. 335
Radio switch	XS 1	XS 1	XS 1	-	XS 1	XS 1	XS 1	XS 1	-	P. 350
Radio receiver	XE 1	XE 1	XE 1	-	XE 1	XE 1	XE 1	XE 1	-	P. 350
Speed controller	ST 1 STU 1	-	-	-	-	ST 1 STU 1	-	-	-	P. 41
Speed controller, distribution board	STS 2,5	-	-	-	-	STS 2,5	-	-	-	P. 339
Time delay switch	VZ 6 VZ 12 VZ 24 C	-	-	-	-	VZ 6 VZ 12 VZ 24 C	-	-	-	P. 342
Interval switch	VZI 10	-	-	-	-	VZI 10	-	-	-	P. 342
Follow-up relay	NRS 10	-	-	-	-	NRS 10	-	-	-	P. 343
Hygrostat	HY 230 HY 230 I	HY 230 HY 230 I	-	-	HY 230 HY 230 I	HY 230 HY 230 I	HY 230 HY 230 I	-	-	P. 348

*Adaptation by the customer needed



Features

- Intelligently programmed small room fan for very demanding requirements.
- 2 performance levels.
- Designer cover conceals the inlet.
- For air extraction.
- Combines large air volumes with high pressure.
- With VDE GS symbol.
- IP X5 degree of protection for safety in the bathroom.
- Protection class II.
- Thermal overload protection.
- Suitable for continuous operation.
- Colour: traffic white, similar to RAL 9016.
- Housing made of impact resistant plastic material.

Operating programs

- Can be adjusted using jumper in unit.
- Comfort program (preset)
 - User present: Level 1
 - Overrun time: Level 2
- Demand program
 - User present: Level 2
 - Overrun time: Level 1
- Economy program
 - User present: Level 1
 - Overrun time: Level 1
- Power program
 - User present: Level 2
 - Overrun time: Level 2

- Exception, no operating programs:
 - ECA 150 ipro
 - ECA 150 ipro RC
 - ECA 150 ipro RCH
 - ECA 150 ipro K
 - ECA 150 ipro KRC
 - ECA 150 ipro KRCH.
- For more details, see page 32.

Motor

- Energy-saving robust motor with ball bearings, maintenance-free.
- Suitable for continuous operation.

Mounting information

- Compatible with ECA predecessor models DN150, because recessed screw holes and cable entry are in the same place.
- Wall and ceiling installation is possible

Electrical connection

- Electrical connection can be either surface- or recessed-mounted.

Safety instructions

- All ECA 150 ipro units can be used in protection area 1 in accordance with DIN VDE 0100-701.
- For details see planning instructions.

Models

- Either as fixed internal grille or K version (ECA 150 ipro K...) with electrically operated internal shutter.
- The following models are available
 - Standard model
 - Adjustable start delay and overrun time
 - Humidity control
 - Motion detector
 - Radio receiver
 - Radio receiver and humidity control
- For more details, see page 32.

Technical data

Article	Art. No.	Model	U _{nom}	f _{nom}	Air flow volume	Rotating speed	Power consumption	I _{max}	T _{max} at I _{max}	Sound pressure level	Degree of protection	Mains cable
			V	Hz	m ³ /h	1/min	W	A	°C	dB(A)	IP	mm ²
ECA 150 ipro	0084.0085	Standard model	230	50	200/250	1,672/2,189	15/19	0.09	40	33/40 ¹⁾	X5	5 x 1.5
ECA 150 ipro VZC	0084.0086	Adjustable start delay and overrun time	230	50	200/250	1,672/2,189	15/19	0.09	40	33/40 ¹⁾	X5	5 x 1.5
ECA 150 ipro H	0084.0089	Humidity control	230	50	200/250	1,672/2,189	15/19	0.09	40	33/40 ¹⁾	X5	3 x 1.5
ECA 150 ipro B	0084.0090	Motion detector	230	50	200/250	1,672/2,189	15/19	0.09	40	33/40 ¹⁾	X5	3 x 1.5
ECA 150 ipro RC	0084.0087	Radio receiver	230	50	200/250	1,672/2,189	15/19	0.09	40	33/40 ¹⁾	X5	5 x 1.5
ECA 150 ipro RCH	0084.0088	Radio receiver and humidity control	230	50	200/250	1,672/2,189	15/19	0.09	40	33/40 ¹⁾	X5	5 x 1.5
ECA 150 ipro K	0084.0091	Standard model	230	50	200/250	1,672/2,189	18/22	0.11	40	33/40 ¹⁾	X5	5 x 1.5
ECA 150 ipro KVZC	0084.0092	Adjustable start delay and overrun time	230	50	200/250	1,672/2,189	18/22	0.11	40	33/40 ¹⁾	X5	5 x 1.5
ECA 150 ipro KH	0084.0095	Humidity control	230	50	200/250	1,672/2,189	18/22	0.11	40	33/40 ¹⁾	X5	3 x 1.5
ECA 150 ipro KB	0084.0096	Motion detector	230	50	200/250	1,672/2,189	18/22	0.11	40	33/40 ¹⁾	X5	3 x 1.5
ECA 150 ipro KRC	0084.0093	Radio receiver	230	50	200/250	1,672/2,189	18/22	0.11	40	33/40 ¹⁾	X5	3 x 1.5
ECA 150 ipro KRCH	0084.0094	Radio receiver and humidity control	230	50	200/250	1,672/2,189	18/22	0.11	40	33/40 ¹⁾	X5	3 x 1.5

¹⁾ Distance 3 m, Free-field conditions



Dimensions [mm]

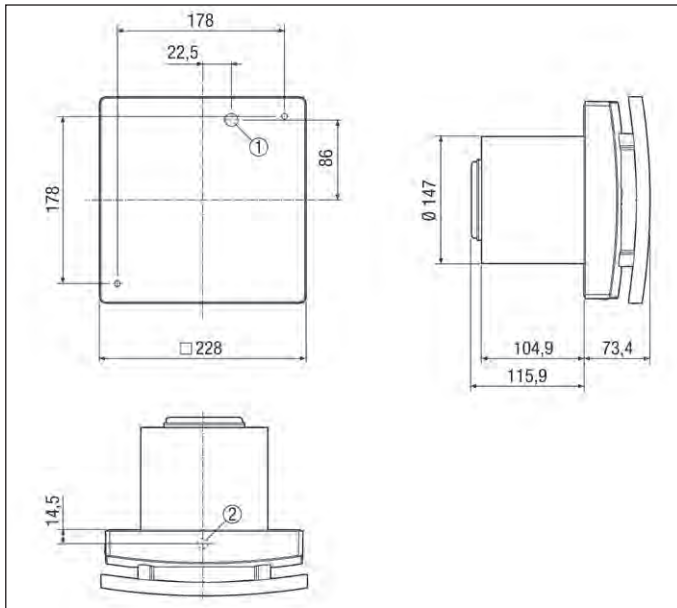

- ① Cable entry for recessed-mounted connection
- ② Cable bushing for surface-mounted connection

Characteristic curve

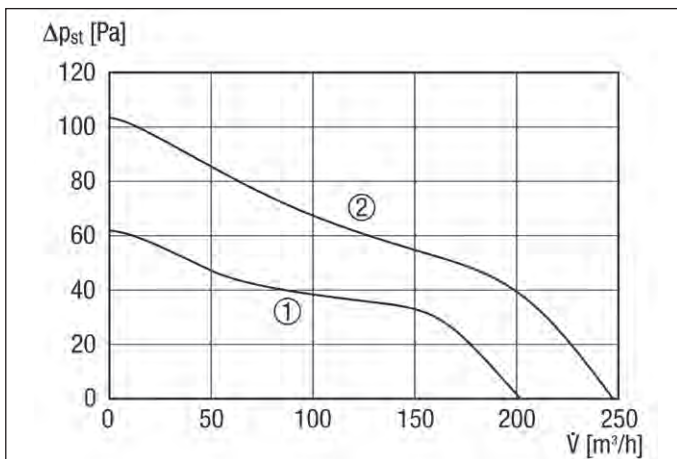

- ① Performance level 1
- ② Performance level 2

Important accessories

Shutter



P. 37

Airstream-operated shutter for air extraction, DN 150

AP 150 0059.0952

Dimensions [mm]

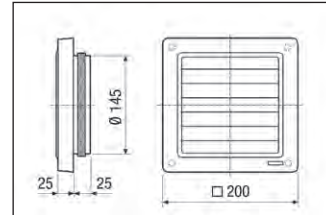

External grille



P. 38

External grille for ventilation and air extraction, DN 150

SG 15 0059.0904

Dimensions [mm]

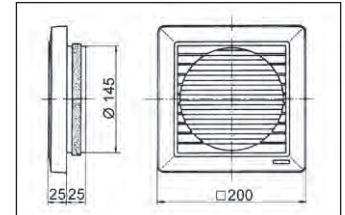

Wall sleeve



P. 39

Extendable synthetic material wall sleeves, for fans with the nominal size 150

WH 150 0059.1050

Dimensions [mm]

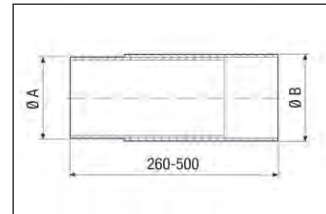

Spacing frame



P. 39

Spacer for installing ECA 150 .. small room fans in square wall sleeves

ECA15-EMA16 0092.0251

Radio switch



P. 40

Radio switch for wirelessly switching ECA ... ipro RC/RCH and ER 100 RC fans

DS RC 0157.0832

Article	A	B
WH 150	160	168

Door ventilation grilles



P. 40

Door ventilation grille for bathroom, WC or kitchen

MLK 30 white 0151.0123
MLK 45 white 0151.0126

The following models are available:

Either as fixed internal grille or K version (ECA 150 ipro K...) with electrically operated internal shutter.

Standard Standard model

- On/off with light switch or separate switch.
- Operation either at level 1 or 2.
- Can be operated at two levels with standard double reversing switch.
- Speed controllable.

VZC Model with adjustable start delay and overrun time

- On/off with light switch or separate switch.
- All 4 operating programs available.
- The sequence of the performance levels depends on which operating program is selected.
- Start delay can be set to different levels using easily accessible switches: 0/50/90/120 sec.
- Overrun time can be set to different levels using easily accessible switches: 0/8/17/25 min.
- The time set is displayed using LEDs during the setting.
- Not speed-controllable.

H Model with automatic humidity control

- Barrier-free product as the fan switches itself on and off via the humidity sensor.
- Switch-on humidity does not have to be set. Fan monitors the room humidity.
- Automatic air extraction depending on room humidity, at level 1 and 2.
- Can be operated without a switch, can also be switched using a separate switch as option.
- Start delay can be set to different levels using easily accessible switches (only if controlled using switch): 0/50/90/120 sec.
- Overrun time can be set to different levels using easily accessible switches: 8/17/25 min. An overrun time of 0 min can only be set for the control using a separate switch.
- The time set is displayed using LEDs during the setting.
- Not speed-controllable.

B Model with motion detector

- Barrier-free product as the fan switches itself on and off via the motion sensor.
- All 4 operating programs available.
- The sequence of the performance levels depends on which operating program is selected.
- Can be operated without a switch, can also be switched using a separate switch as option.
- No start delay.
- Overrun time can be set to different levels using easily accessible switches: 0/8/17/25 min.
- The time set is displayed using LEDs during the setting.
- Effective range of the motion detector: 5 m.
- Horizontal monitoring range of the motion detector: 100°.
- Vertical monitoring range of the motion detector: 82°.
- Not speed-controllable.

RC Model with radio receiver

- With integrated 868 MHz radio receiver.
- On/off via DS RC radio switch or separate RLS RC control.
- The two speeds can be selected either on the radio switch or control.
- Not speed-controllable.

RCH Model with radio receiver and humidity control

- With integrated 868 MHz radio receiver and humidity control.
- Switch-on humidity does not have to be set. Fan monitors humidity curve. Automatic air extraction depending on room humidity, at level 1 or 2.
- Can be switched with separate DS RC radio switch or separate RLS RC control.
- The two speeds can be selected either on the radio switch or control.
- Not speed-controllable.

Selection help

Article	Article no.	electrically operated internal shutter	On/Off via integrated sensor	On/Off via (light) switch	adjustable start delay (sec.)	adjustable overrun time (min.)	Available levels	step switching via
ECA 150 ipro	0084.0085			X			1 or 2	without step switching; Terminal assignment selects step 1 or 2
ECA 150 ipro VZC	0084.0086			X	0/50/90/120	0/8/17/25	1 and 2	Reversing switch (supplied by the customer) 4 operating programs
ECA 150 ipro H	0084.0089		Humidity	X	0/50/90/120*	8/17/25**	1 and 2	Humidity curve / 4 operating programs***
ECA 150 ipro B	0084.0090		Movement	X		0/8/17/25	1 and 2	4 operating programs
ECA 150 ipro RC	0084.0087						1 and 2	Radio switch, room air control
ECA 150 ipro RCH	0084.0088		Humidity				1 and 2	Humidity curve / radio switch, room air control
ECA 150 ipro K	0084.0091	X		X			1 or 2	without step switching; Terminal assignment selects step 1 or 2
ECA 150 ipro KVZC	0084.0092	X		X	0/50/90/120	0/8/17/25	1 and 2	Reversing switch (supplied by the customer) 4 operating programs
ECA 150 ipro KH	0084.0095	X	Humidity	X	0/50/90/120*	8/17/25**	1 and 2	Humidity curve / 4 operating programs***
ECA 150 ipro KB	0084.0096	X	Movement	X		0/8/17/25	1 and 2	4 operating programs
ECA 150 ipro KRC	0084.0093	X					1 and 2	Radio switch, room air control
ECA 150 ipro KRCH	0084.0094	X	Humidity				1 and 2	Humidity curve / radio switch, room air control

* Start delay available when using an optional switch (e.g. light switch)
 ** Overrun time of 0 min available when using an optional switch (e.g. light switch)
 *** 4 operating programs available when using an optional switch (e.g. light switch)

Accessories selection table

	ECA 150 ipro ECA 150 ipro K	ECA 150 ipro VZC ECA 150 ipro KVZC	ECA 150 ipro H ECA 150 ipro KH	ECA 150 ipro B ECA 150 ipro KB	ECA 150 ipro RC ECA 150 ipro KRC	ECA 150 ipro RCH ECA 150 ipro KRCH	see
Spacing frame	ECA15-EMA16	ECA15-EMA16	ECA15-EMA16	ECA15-EMA16	ECA15-EMA16	ECA15-EMA16	P. 39
Room air control	-	-	-	-	RLS RC	RLS RC	P. 98
Radio switch	-	-	-	-	DS RC	DS RC	P. 40
Shutter	AP 150	AP 150	AP 150	AP 150	AP 150	AP 150	P. 37
External grille	SG 15	SG 15	SG 15	SG 15	SG 15	SG 15	P. 38
Wall sleeve	WH 150	WH 150	WH 150	WH 150	WH 150	WH 150	P. 39
Outside air opening	ALD 10 ALD 125 ALD 125 VA ALD 160 ALD 160 VA	ALD 10 ALD 125 ALD 125 VA ALD 160 ALD 160 VA	ALD 10 ALD 125 ALD 125 VA ALD 160 ALD 160 VA	ALD 10 ALD 125 ALD 125 VA ALD 160 ALD 160 VA	ALD 10 ALD 125 ALD 125 VA ALD 160 ALD 160 VA	ALD 10 ALD 125 ALD 125 VA ALD 160 ALD 160 VA	P. 308
Roof outlet	DF 160..*	DF 160..*	DF 160..*	DF 160..*	DF 160..*	DF 160..*	P. 306
Roofing tile	DP 160..*	DP 160..*	DP 160..*	DP 160..*	DP 160..*	DP 160..*	P. 306
Mounting clamp	BS 160*	BS 160*	BS 160*	BS 160*	BS 160*	BS 160*	P. 306
Rain protection grille	RG 160*	RG 160*	RG 160*	RG 160*	RG 160*	RG 160*	P. 306
Door ventilation grille	MLK 30 white MLK 45 white	MLK 30 white MLK 45 white	MLK 30 white MLK 45 white	MLK 30 white MLK 45 white	MLK 30 white MLK 45 white	MLK 30 white MLK 45 white	P. 40
Flexible aluminium duct	AFR 150	AFR 150	AFR 150	AFR 150	AFR 150	AFR 150	P. 319
Radio switch	XS 1	XS 1	XS 1	XS 1	-	-	P. 350
Radio receiver	XE 1	XE 1	XE 1	XE 1	-	-	P. 350
Speed controller	ST 1 STU 1	-	-	-	-	-	P. 41
Speed controller, distribution board	STS 2,5	-	-	-	-	-	P. 339
Time delay switch	VZ 6 VZ 12 VZ 24 C	-	-	-	-	-	P. 342
Interval switch	VZI 10	-	-	-	-	-	P. 342
Follow-up relay	NRS 10	-	-	-	-	-	P. 343
Hygrostat	HY 230 HY 230 I	HY 230 HY 230 I	-	HY 230 HY 230 I	-	-	P. 348

*Adaptation by the customer needed



Models

- ECA 11 E:
 - Suitable for DN 100 ducts.
 - With VDE-GS symbol.
- ECA 15/4 E and ECA 15/2 E:
 - Suitable for DN 150 ducts.

Features

- Duct-mounted fan for installation in folded spiral-seams ducts.
- For ventilation or air extraction, depending on the installation position in the duct.
- Housing made of impact resistant plastic material.
- Protection class II.
- Colour: traffic white, similar to RAL 9016.
- Protection against accidental contact according to DIN EN 13857 is required, e.g. by SG protective grille and AP shutter.
- Protective grille and airstream-operated shutter as accessories.
- Speed controllable, exception: ECA 15/2 E.

Motor

- Robust motor with ball bearings, maintenance-free.
- Suitable for continuous operation.
- Thermal overload protection.
- There can be a physically induced humming noise at lower speeds, through the use of phase angle technology.

Mounting instructions

- Suitable for any installation position in dry rooms.

Technical data

Article	Art. No.	U _{nom} V	f _{nom} Hz	Air flow volume m ³ /h	Rotating speed 1/min	Power consumption W	I _{max} A	T _{max} at I _{max} °C	Sound pressure level dB(A)	Degree of protection IP	Mains cable mm ²
DN 100											
ECA 11 E	0080.0460	230	50/60	105	2,550	13	0.1	40	37 ¹⁾	45	3 x 1.5
DN 150											
ECA 15/2 E	0080.0990	230	50/60	320	2,700	38	0.25	40	43 ¹⁾	44	3 x 1.5
ECA 15/4 E	0080.0991	230	50/60	170	1,420	18	0.12	40	29 ¹⁾	44	3 x 1.5

¹⁾ Distance 3 m, Free-field conditions

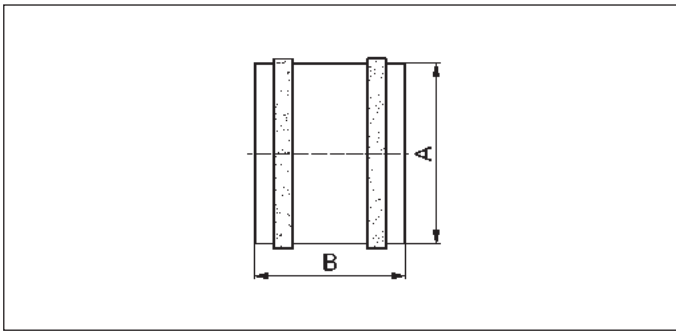

ECA 11 E

Dimensions [mm]

Article	A	B
ECA 11 E	98	109
ECA 15/2 E	146	120
ECA 15/4 E	146	120

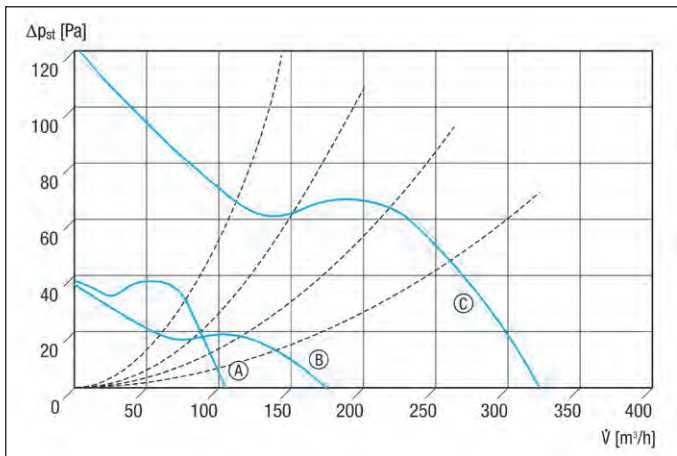
Characteristic curves for ECA 11 E, ECA 15/4 E and ECA 15/2 E

- Ⓐ ECA 11 E - U = 230 V, f = 50 Hz, n = 2500 rpm
- Ⓑ ECA 15/4 E - U = 230 V, f = 50 Hz, n = 1375 rpm
- Ⓒ ECA 15/2 E - U = 230 V, f = 50 Hz, n = 2600 rpm

Important accessories
Shutters

P. 37

Airstream-operated shutters for air extraction, DN 100

 AP 100 0059.1058
 AP 100 B 0059.0957

Dimensions [mm]

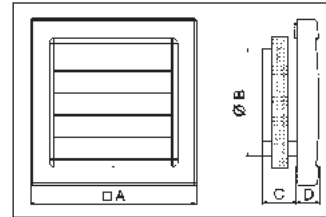

Article	A	B	C	D
AP 100	150	98	29	21
AP 100 B	150	98	29	21

Shutter

P. 37

Airstream-operated shutter for air extraction, DN 150

AP 150 0059.0952

Dimensions [mm]

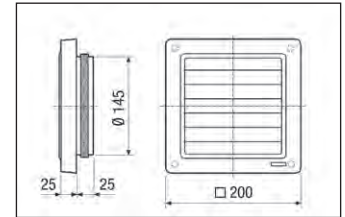

External grilles

P. 37

External grille for ventilation and air extraction, DN 100

 SG 100 0059.1054
 SG 100 B 0059.0958

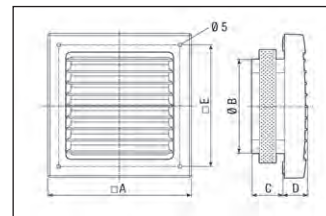
Dimensions [mm]



Article	A	B	C	D	E
SG 100	150	98	29	22.5	130
SG 100 B	150	98	29	22.5	130

External grille

P. 38

External grille for ventilation and air extraction, DN 150

SG 15 0059.0904

Dimensions [mm]

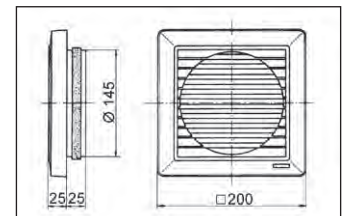

Wall sleeves

P. 39

Synthetic material wall sleeves, for nominal sizes 100 and 150, extendible

 WH 100 0059.1030
 WH 150 0059.1050

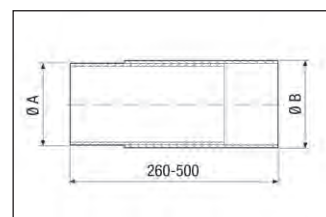
Dimensions [mm]



Article	A	B
WH 100	110	114
WH 150	160	168

Door ventilation grilles

P. 40

Door ventilation grille for bathroom, WC or kitchen

 MLK 30 white 0151.0123
 MLK 45 white 0151.0126

Accessories selection table

	ECA 11 E	ECA 15/2 E	ECA 15/4 E	see
Shutter	AP 100 AP 100 B	AP 150	AP 150	P. 37
External grille	SG 100 SG 100 B	SG 15	SG 15	P. 38
Wall sleeve	WH 100	WH 150	WH 150	P. 39
Outside air opening	ALD 10 ALD 125 ALD 125 VA ALD 160 ALD 160 VA	ALD 10 ALD 125 ALD 125 VA ALD 160 ALD 160 VA	ALD 10 ALD 125 ALD 125 VA ALD 160 ALD 160 VA	P. 308
Roof outlet	DF 125..*	DF 125..*	DF 160..**	P. 306
Roofing tile	DP 125..*	DP 125..*	DP 160..**	P. 306
Mounting clamp	BS 125*	BS 125*	BS 160**	P. 306
Rain protection grille	RG 125*	RG 125*	RG 160**	P. 306
Internal grille	ESG 10/2	–	–	P. 38
Door ventilation grille	MLK 30 white MLK 45 white	MLK 30 white MLK 45 white	MLK 30 white MLK 45 white	P. 40
Flexible aluminium duct	AFR 100	AFR 150	AFR 150	P. 319
Step switch	FS 4	FS 4	FS 4	P. 335
Radio switch	XS 1	XS 1	XS 1	P. 350
Radio receiver	XE 1	XE 1	XE 1	P. 350
Speed controller	ST 1 STU 1	–	ST 1 STU 1	P. 41
Speed controller, distribution board	STS 2,5	–	STS 2,5	P. 339
Time delay switch	VZ 6 VZ 12 VZ 24 C	VZ 6 VZ 12 VZ 24 C	VZ 6 VZ 12 VZ 24 C	P. 342
Interval switch	VZI 10	VZI 10	VZI 10	P. 342
Hygrostat	HY 230 HY 230 I	HY 230 HY 230 I	HY 230 HY 230 I	P. 348

*Customer must purchase reducer

**Adaptation by the customer needed

**Shutters
AP 100/120**



- Airstream-operated shutters for air extraction.
- Exterior wall connection when using wall sleeve WH 100 or WH 120.
- AP 100 B: Shutter in brown.
- With covered screw holes.
- Sealing tape included in the scope of delivery.

Dimensions [mm]

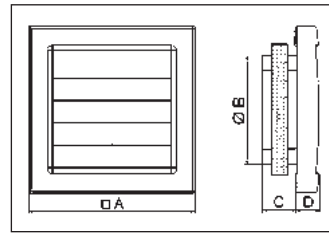

Article	A mm	B mm	C mm	D mm
AP 100	150	98	29	21
AP 100 B	150	98	29	21
AP 120	172	113	30	23

Common features

Loss of pressure	10 Pa
Material	Synthetic material, weather and UV resistant
Installation site	Wall
Max. ambient temperature	60 °C
Air direction	Air extraction
Type of shutter	Airstream-operated opening/closing

Article	Art. No.	Nominal size mm	Colour
AP 100	0059.1058	100	Traffic white, similar to RAL 9016
AP 100 B	0059.0957	100	Brown
AP 120	0059.0950	125	Traffic white, similar to RAL 9016

**Shutter
AP 150**



- Shutter for air extraction.
- Exterior wall connection when using WH 150 wall sleeve.
- Sealing tape included in the scope of delivery.

Dimensions [mm]

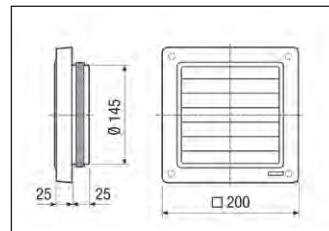

Article	Art. No.
AP 150	0059.0952

Features

Nominal size	150 mm
Loss of pressure	10 Pa
Material	Synthetic material, weather and UV resistant
Colour	Traffic white, similar to RAL 9016
Installation site	Wall
Max. ambient temperature	60 °C
Air direction	Air extraction
Type of shutter	Airstream-operated opening/closing

**External grilles
SG 100/120**



- External grille for air extraction and ventilation.
- Exterior wall connection when using wall sleeve WH 100 or WH 120.
- SG 100 B: External grille in brown.
- With covered screw holes.
- Sealing tape included in the scope of delivery.
- Replacement air filter for SG 120: SF 120.

Dimensions [mm]

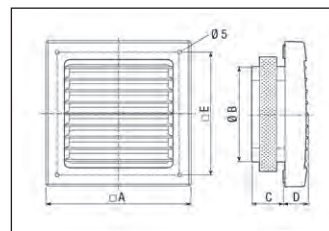

Article	A mm	B mm	C mm	D mm	E mm
SG 100	150	98	29	22.5	130
SG 100 B	150	98	29	22.5	130
SG 120	172	118	30	23	152

Common features

Material	Synthetic material, weather and UV resistant
Installation site	Wall
Max. ambient temperature	60 °C
Air direction	Ventilation and air extraction

Article	Art. No.	Nominal size mm	Colour
SG 100	0059.1054	100	Traffic white, similar to RAL 9016
SG 100 B	0059.0958	100	Brown
SG 120	0059.0951	125	Traffic white, similar to RAL 9016

**Air filter, replacement
SF 120**

- Replacement filter for SG 120 external grille.

Article	Art. No.
SF 120	0093.0925

Features

Nominal size	120 mm
Filter class	G2
Width	140 mm
Height	140 mm
Depth	7 mm
Packing unit	5 pieces

**External grille
SG 15**



- External grille for air extraction and ventilation.
- Exterior wall connection when using WH 150 wall sleeve.
- With galvanised protective grille.
- Sealing tape included in the scope of delivery.

Dimensions [mm]

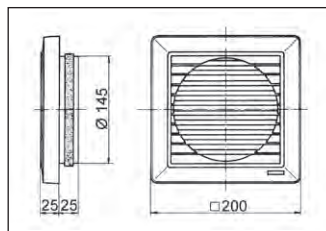

Features

Nominal size	150 mm
Material	Synthetic material, weather and UV resistant
Colour	Traffic white, similar to RAL 9016
Installation site	Wall
Max. ambient temperature	60 °C
Air direction	Ventilation and air extraction

Article	Art. No.
SG 15	0059.0904

**Internal grille
ESG 10/2**



- Internal grille for ventilation and air extraction.
- With air filter.
- With covered screw holes.
- Cover can be removed without tools for cleaning.
- Sealing tape included in the scope of delivery.
- Accessories: ZRF.. spare air filter.

Dimensions [mm]

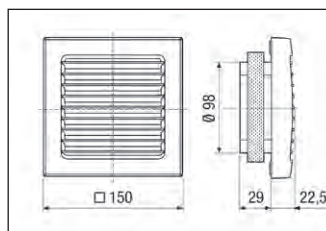

Features

Nominal size	100 mm
Filter class	G2
Material	Synthetic material
Colour	Traffic white, similar to RAL 9016
Installation site	Wall
Max. ambient temperature	60 °C
Air direction	Ventilation and air extraction

Article	Art. No.
ESG 10/2	0059.0947

Exhaust air pressure losses

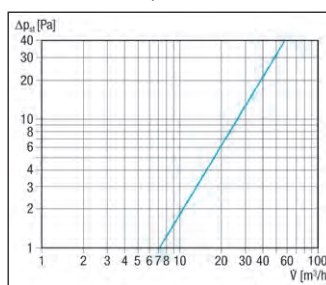

**Air filter, replacement
ZRF**

- Replacement filter for ER-ZR second room connection kit and for ESG 10/2 internal grille.

Article	Art. No.
ZRF	0093.0923

Features

Nominal size	100 mm
Filter class	G2
Width	125 mm
Height	125 mm
Depth	10 mm
Packing unit	5 pieces

**Wall sleeves
WH 100/120/150**



- Wall sleeve for wall and ceiling installations.
- Variable length.

Dimensions [mm]

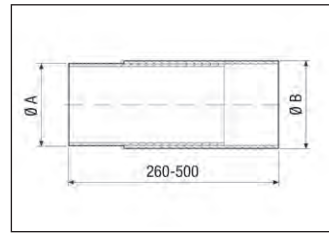

Common features

Material	Synthetic material
Installation site	Wall/Ceiling

Article	Art. No.	Nominal size mm
WH 100	0059.1030	100
WH 120	0059.1031	125
WH 150	0059.1050	150

Article	A mm	B mm	Needed core hole mm
WH 100	110	114	min. 115
WH 120	130	135	min. 136
WH 150	160	168	min. 169

**Mounting plate
ZM 11**



- Mounting plate for installing MAICO small room fans in square shaft openings.
- Can be matched to any wall decorations (e.g. wallpaper).

Dimensions [mm]

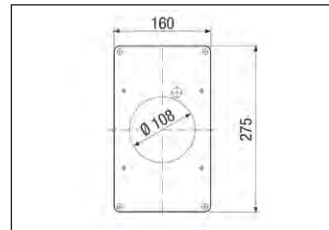

Material thickness 3 mm

Features

Nominal size	100 mm
Material	Synthetic material
Colour	Traffic white, similar to RAL 9016
Installation site	Channel

Article	Art. No.
ZM 11	0059.0696

**Spacing frame
ECA-DR**



- Spacing frame for the connection of small room fans of the ECA 100 ipro group.
- Using a frame makes surface-mounted cable routing possible with ECA 100 ipro... units.
- Through the use of the ECA-DR, the small room fan can be built into flat channel elbows without projection.
- Do not install on windows or laminated glass.
- Scope of delivery: Spacer with 3 spacing frames, 4 x 100 mm wooden screws, 4 dowels, 3 screws for fastening the fan and operating instructions.

Dimensions [mm]

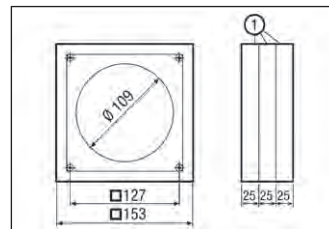

① Spacer elements, detachable

Features

Material	Synthetic material
Colour	White
Installation site	Wall/Ceiling

Article	Art. No.
ECA-DR	0092.0550

**Spacing frame
ECA15-EMA16**



- Spacer for mounting ECA 150 ipro fans in WH 16 square wall sleeves used for previously fitted EMA 16, EMA 17 and EMA 18 fans.

Features

Material	Solid foam
Colour	Black
Installation site	Wall/Ceiling
Width	185 mm
Height	185 mm
Depth	60 mm

Article	Art. No.
ECA15-EMA16	0092.0251

Sensor cable for AKE 100 cable 6 m

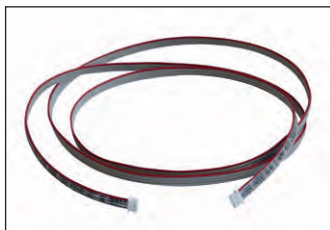

- Optional sensor connection cable for small room fan AKE, if the standard cable (1 m) is too short.

Article	Art. No.
sensor cable 6 m	0157.0588

Features

Length	6 m
--------	-----

Door ventilation grilles MLK



- Door ventilation grille for bathroom, WC or kitchen.
- Free cross section in accordance with FeuVo 80 (German Heating Directives) and TRGI 86 (German Directives for Gas Installation).
- MLK 30:
Door cut-out:
275 x 105 mm,
external dimension:
295 x 120 mm.
- MLK 45:
Door cut-out:
436 x 76 mm,
external dimension:
457 x 92 mm.

Article	Art. No.
MLK 30 white	0151.0123
MLK 45 white	0151.0126

Common features

Material	Synthetic material
Synthetic material definition	PVC-free polystyrene
Colour	White
Installation site	Door
Open cross section	154 cm ²
Air direction	Ventilation and air extraction
Minimum door leaf thickness	30 mm

Radio switch DS RC



- EnOcean radio switch.
- The radio switch can be used individually with the ECA ... ipro RC/RCH, ER 100 RC fans or the MAICOsmart system.
- The radio switch can also be used in combination with the EnOcean plug-in module E-SM in order to control the WS 160 Flat, WS 170 KBR.../WS 170 KBL..., WS 320/470 and WR 310/410 centralised ventilation units using EnOcean.
- For redevelopments and retrofit installations – no painting or wallpapering.
- Tiles don't need to be removed or renewed.
- Application wherever no control cable can be installed.
- Radio switch can be used on the move.
- Radio switch requires no batteries.
- Radio switch can be screwed on or attached to a glass surface.
- Simple transmitter teaching-in saves on time-consuming programming.

Article	Art. No.
DS RC	0157.0832



Features

Battery	not required
Degree of protection	IP 20
Material	Synthetic material
Colour	Pure white, similar to RAL 9010
Type of installation	Surface-mounted
Installation site	Wall
Mains cable	not required
Minimum ambient temperature	-25 °C
Max. ambient temperature	65 °C
Width	83 mm
Height	83 mm
Depth	16 mm
Transmission range in the building	30 m
Radio frequency	868.3 MHz

**Speed controllers
ST**

Article	Art. No.	Maximum load A	Minimum load A
ST 1	0157.0810	1	0.1
ST 2,5	0157.0811	2.5	0.1
ST 5	0157.0812	4.3	0.2

- Speed controller for linear control of the fans.
 - Minimum speed adjustable.
 - Function principle: Phase angle control.
 - Recommended distance from radios and televisions: 3 m.
 - Switch on the fans at maximum speed by turning the knob. Turning further reduces the speed.
 - Splash water protected.
 - With operating indicator light.
 - VDE-tested.
 - Additional switching contact (230 V) e.g. for controlling a shutter.
- There can be a physically induced humming noise at lower speeds, through the use of phase angle technology. TRE... 5-step transformers are therefore used for speed control in rooms requiring quiet fan operations.
 - Assembly on walls possible; avoid ceiling installation because of temperature build-up.

Article	Width mm	Height mm	Depth mm
ST 1	81	81	63
ST 2,5	81	81	63
ST 5	85	170	63

Common features

U _{nom}	230 V
Degree of protection	IP 44
Colour	Pure white, similar to RAL 9010
Type of installation	Surface-mounted

**Speed controllers
STU**

Article	Art. No.	Maximum load A	Minimum load A
STU 1	0157.0814	1	0.1
STU 2,5	0157.0815	2.5	0.1
STU 5	0157.0816	4.3	0.2

- Speed controller for linear control of the fans.
 - Minimum speed adjustable.
 - Function principle: Phase angle control.
 - Recommended distance from radios and televisions: 3 m.
 - Switch on the fans at maximum speed by turning the knob. Turning further reduces the speed.
 - With operating indicator light.
 - VDE-tested.
 - Additional switching contact (230 V) e.g. for controlling a shutter.
- There can be a physically induced humming noise at lower speeds, through the use of phase angle technology. TRE... 5-step transformers are therefore used for speed control in rooms requiring quiet fan operations.
 - Assembly on walls possible; avoid ceiling installation because of temperature build-up.

Article	Width mm	Height mm	Depth mm
STU 1	81	81	56
STU 2,5	81	81	56
STU 5	81	152	64

Common features

U _{nom}	230 V
Degree of protection	IP 20
Colour	Pure white, similar to RAL 9010
Type of installation	Recessed-mounted

Distances to be maintained - protection areas in bathrooms in accordance with DIN VDE 0100- 701

- Bathrooms are divided into 3 areas, in which different requirements apply to the degree of protection required for the electrical equipment.
- If water jets occur in area 1 and 2, select units with an IP X5 degree of protection.
- Depending on the degree of protection of the ECA product selected (see Technical data product page), the required distances to the shower/bath

area will differ. The following diagram outlines the corresponding distances.

Sector	Permitted voltage	IP-degree of protection for current-using equipment
0	AC 12 V or DC 30 V	IP X7
1	230 V (fans)	IP X5
2	230 V	IP X4, (IP X5 if there is a risk of water jets)

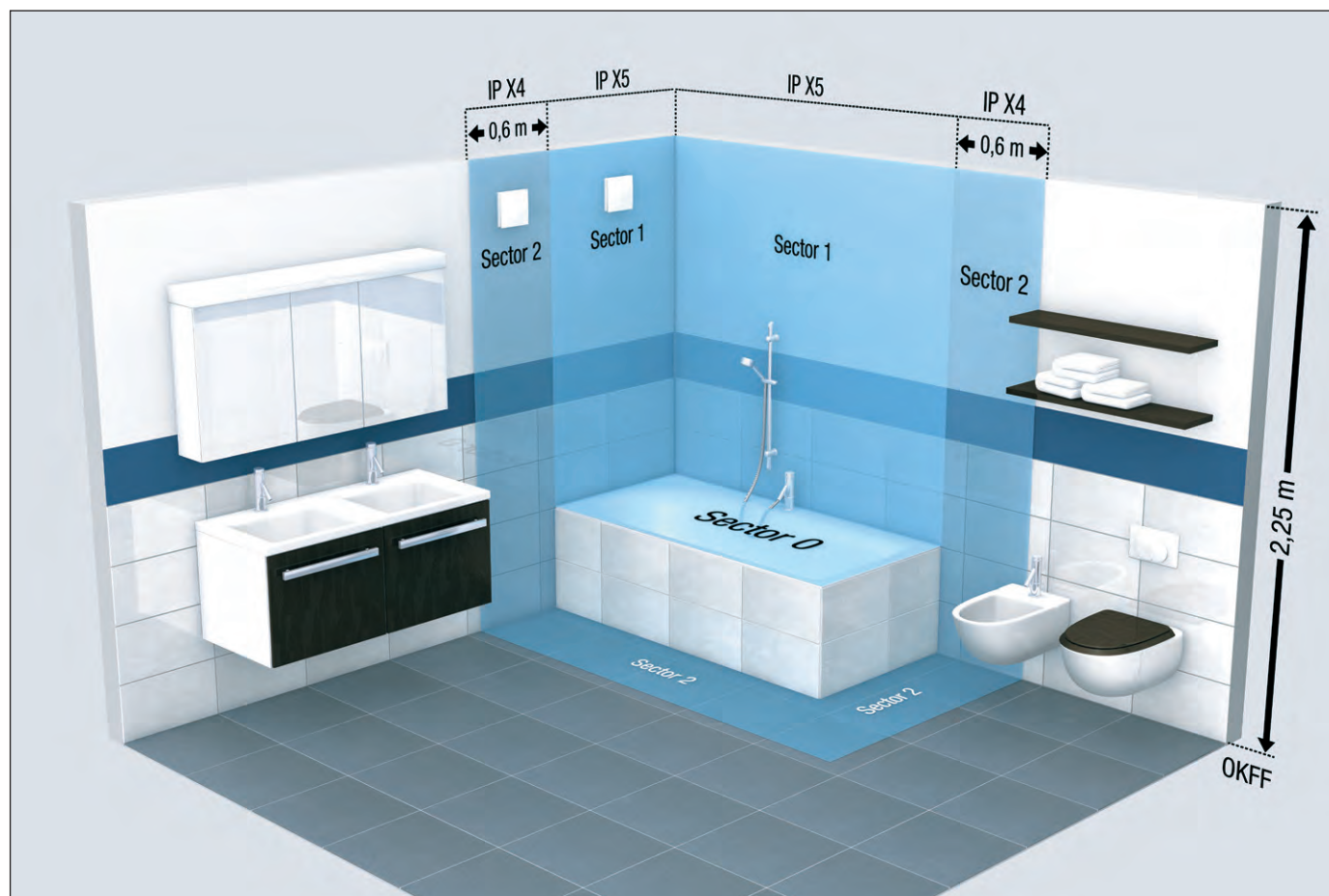

Air intake

- Supply air intake within the living unit: The domestic air supply must be set up so that virtually no air can flow into the living areas from the kitchen, bathroom and WC. A room from which the air has to be extracted must be fitted with a non-closable, free supply air cross section, therefore install, e.g. an MLK door ventilation grille.

- ECA fans in domestic units with air-ventilated fireplaces, e.g. in rooms with open chimneys or stoves: The ECA fans are only allowed to be operated when there is a sufficient inflow of external air into the living area. Please contact the chimney sweep for this.

Condensation

- The duct must be fitted with thermal insulation in order to provide protection against condensation, e.g. ducts in unheated areas.
- In the case of vertically installed ducts, install a condensation connection with a siphon and connect it to the building's drainage system.

Important notes

- Pay attention to DIN VDE 0100, part 701 when installing fans in bathroom or WC areas.
- **ECA fans are not suitable for exhaust air systems that are in accordance with DIN 18017-3.**

Wall mounting of ECA small room fans

Please note the following points when fitting ECA 100 ipro, ECA 150 ipro, ECA piano and ECA 120 series model fans in a wall:

- A minimum distance between the wall and the ceiling must be observed when preparing the wall breakthrough, see diagram.
- Fit a wall sleeve.
- Feed in the connecting cable for surface or recessed mounting.
- ECA 100 ipro and ECA piano only available as recessed-mounted fans.
- Secure the fan using screws during installation.

- The AP shutter prevents cold air from entering when the fan is switched off. Not required with ECA piano and all versions with electrically-operated internal shutter.

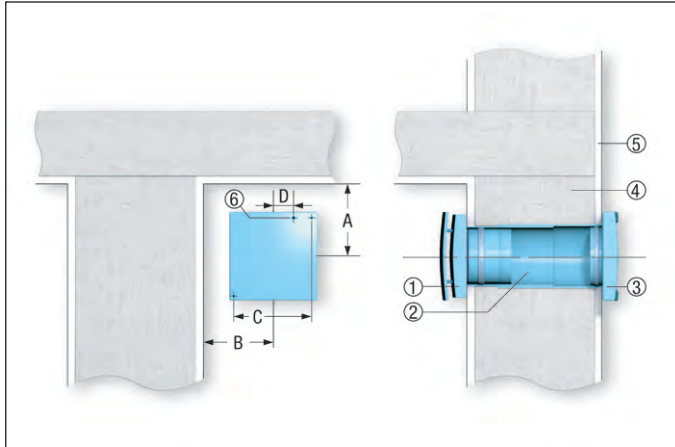

- ① ECA fan
- ② WH wall sleeve
- ③ AP outside shutter
- ④ Masonry
- ⑤ Plaster
- ⑥ Cable entry

	A	B	C	D
ECA 100 ipro	105	85	129	22
ECA piano	90	80	129	24
ECA 120	115	95	152	24
ECA 150 ipro	130	130	178	22.5

Ceiling installation with roof cowl

Please note the following points when fitting ECA 100 ipro, ECA 150 ipro, ECA piano and ECA 120 series model fans in a ceiling in ventilation systems with a roof cowl:

- The minimum distance from the wall must be observed (see wall mounting as well).
- Install the wall sleeve or duct.
- Surface- or recessed-mounted connecting cable guide.
- ECA 100 ipro and ECA piano only available as recessed-mounted fans.
- Drain off any condensation present in the duct using a siphon. Fit a T-piece with siphon in the duct (odour seal) for this purpose.

- Proper duct insulation reduces the build-up of condensation considerably.
- Use a roof cowl with the condensation drain pointing outwards, see recommended accessories.

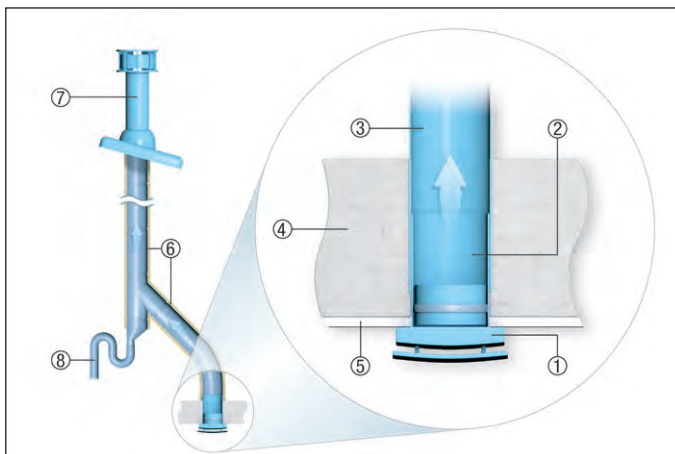

- ① ECA fan
- ② Sleeve WH ...
- ③ Duct, DN 100, DN 125 or DN 150
- ④ Masonry
- ⑤ Plaster
- ⑥ Insulation
- ⑦ DF/DP roof cowl (DN 125/160, possibly adapted by customer)
- ⑧ Condensation drain (siphon), provided by customer

Individual and central ventilation systems

in accordance with DIN 18017-3

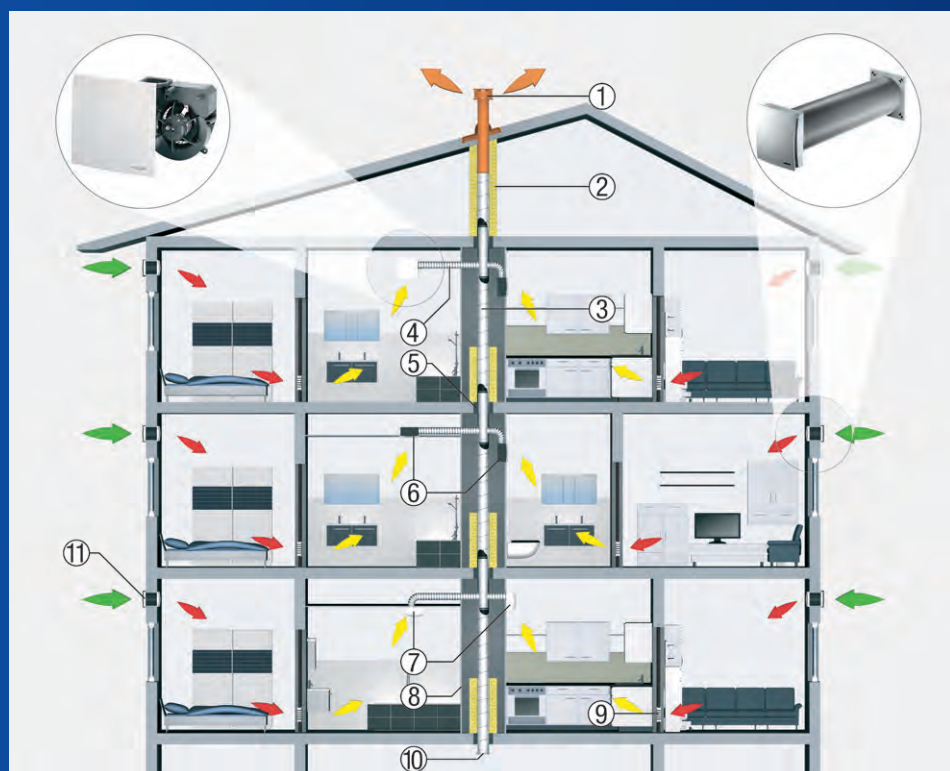

- ① Roof cowl
- ② Insulation (fire protection + preventing the formation of condensation)
- ③ Main duct
- ④ Connecting duct
- ⑤ Ceiling compound
- ⑥ Recessed-mounted housing ER-UP... with ER fan insert
- ⑦ ER-AP surface-mounted fan
- ⑧ Ventilation or installation shaft
- ⑨ MLK door ventilation grille
- ⑩ Cleaning opening, end lid
- ⑪ ALD outside air opening

Decentralised air extraction

- A centralised exhaust air duct runs vertically through the entire building.
- Individual fans in the apartments ensure the necessary exchange of air.
- This allows the ventilation to be controlled individually.
- Models ER ... G/GVZ/GVZC EC can be used to produce continuous ventilation. This results in a hygienic, healthy environment. Even empty apartments can therefore be automatically vented to protect the basic structure of the building.
- This setup can be combined with all the fire protection systems listed below.

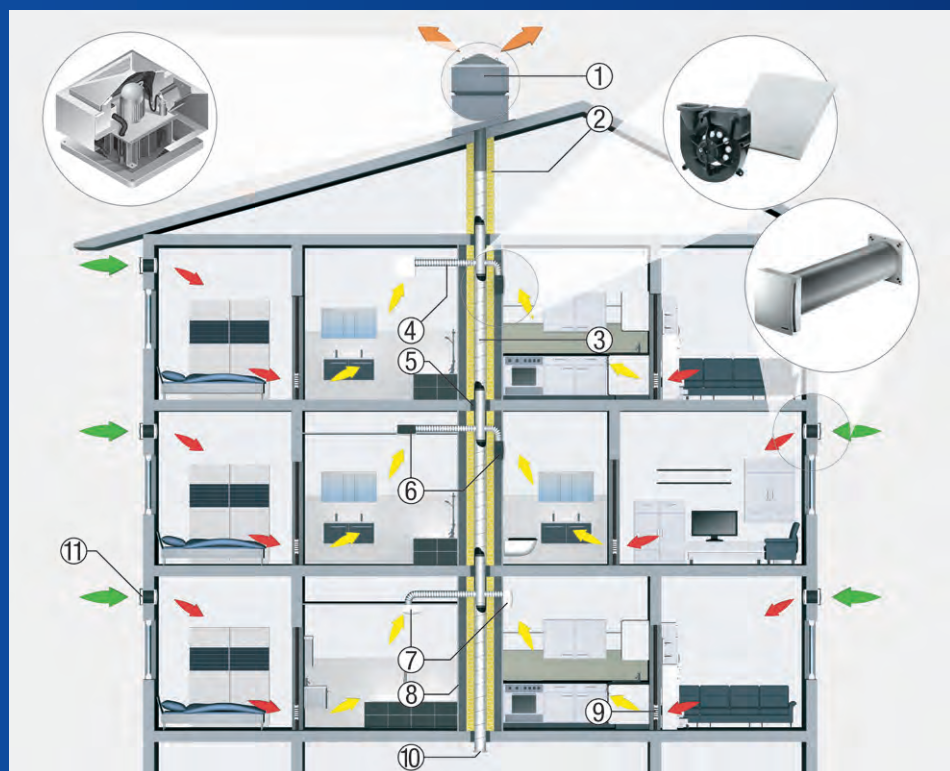

- ① GRD centrifugal roof fan with electric motor
- ② Insulation (fire protection + preventing the formation of condensation)
- ③ Main duct
- ④ Connecting duct
- ⑤ Ceiling compound
- ⑥ ER-UP recessed-mounted housing with recessed-mounted Centro exhaust air element
- ⑦ Centro exhaust air element, surface-mounted
- ⑧ Ventilation or installation shaft
- ⑨ MLK door ventilation grille
- ⑩ Cleaning opening, end lid
- ⑪ ALD outside air opening

Centralised air extraction

- A centralised exhaust air duct runs vertically through the entire building.
- Difference from decentralised air extraction: A centralised fan on the roof or in the main duct conveys the stale air to the outside.
- Centralised air extraction therefore offers benefits such as:
 - Health and hygiene thanks to continuous ventilation
 - Dehumidification and maintenance of basic structure of building
 - Air is automatically extracted from empty apartments
 - Automatic air extraction of neighbouring apartments - user cannot intervene
 - Systems engineering accessible at all times - no need to access neighbouring apartments.
- This setup can be combined with all the fire protection systems listed below.

Fire protection systems		Page 46 Page 47 Page 48
ER EC single air extraction systems	NEW!	Page 50
ER-GH recessed-mounted housing		Page 52
For fan insert ER EC		
ER EC fan insert		Page 54
Decentralised solution for single room air extraction, with EC technology		
Covers		
For fan insert ER EC		
1. ER-A 3. ER-AH		
2. ER-AK 4. ER-AB		
Accessories single air extraction system ER EC		Page 56
ER-UP... recessed-mounted housing		Page 58
For fan inserts ER 60 / ER 100 or Centro-M / Centro-E / Centro-H		
1. ER-UP/G 3. ER-UPB		
2. ER-UPD 4. Recessed-mounted housing accessories		
ER single air extraction systems		
ER 60 / ER 100 fan insert		Page 66
Decentralised solution for one and two room air extraction, with and without fire protection		
ER-AP surface-mounted fan		Page 71
Decentralised solution without fire protection		
ER-APB surface-mounted fan, fire protection		Page 74
Decentralised solution with fire protection		
ER single air extraction system accessories		Page 77
Planning instructions ER /ER EC single air extraction system		Page 78
Protection areas, main duct diameter dependent on the number of floors		
Centro centralised ventilation system		
GRD centrifugal roof fan		Page 80
With EC technology and integrated control for constant pressure or constant volumetric flow, up to 3.600 m ³ /h		
Centro-M / Centro-E / Centro-H exhaust air element	NEW! Centro-H	Page 82
With intelligent control, with and without fire protection		
Centro-M-APB / Centro E-APB / Centro H-APB	NEW! Centro-H-APB	Page 84
Exhaust air element, fire protection		
Exhaust air element with intelligent control and fire protection		
Planning instructions Centro centralised air extraction system		Page 86
Centro-M and Centro-E dimensioning with GRD roof fan		

Fire protection systems / system selection

This is how to find the suitable air extraction system taking into account fire protection

Preventive fire protection has an important role to play in planning building services engineering.

The following description will help you to select the required systems.

MAICO provides 5 exhaust air systems which take fire protection into account:

- aeroduct fire protection system
- PAM-GLOBAL RML cast iron ventilation duct system
- Ceiling barrier system
- System with fire-proof shaft
- Air extraction system without fire protection

First answer the question as to whether fire protection is necessary or stipulated.

In order to clarify this question you need:

- Model building regulations
- Local building regulations from the respective authority with implementing ordinances.
- Special building regulations for special types and utilisation of buildings.
- Technical specifications, e.g. DIN, VDI, VDE, VDS .
- Fire protection specification requirements regarding ventilation systems.

If the answer is no, then you have already found a suitable system:

The air extraction system without fire protection.

If fire protection is necessary, please answer this question: Does the installation shaft have any fire resistance e.g. unfinished wall installation with plaster boards?

If your answer to this question is no, the shaft is fire-proof.

The system with fire-proof shaft is the right one then.

If the shaft is not fire-proof, please answer the next question:

Do you require a space-saving, easy-to-install system with a good price - performance ratio?

If your answer to this question is no, the ceiling barrier system is the right system for you.

If your answer is yes, the next question will be:

Do you require a system with folded spiral seams ducts?

If your answer to this question is no, you can use the PAM-GLOBAL RML cast iron ventilation duct system.

If your answer is yes, the aeroduct fire protection system is the right one for you.

The following flow chart will quickly guide you to a suitable system that meets your requirements.

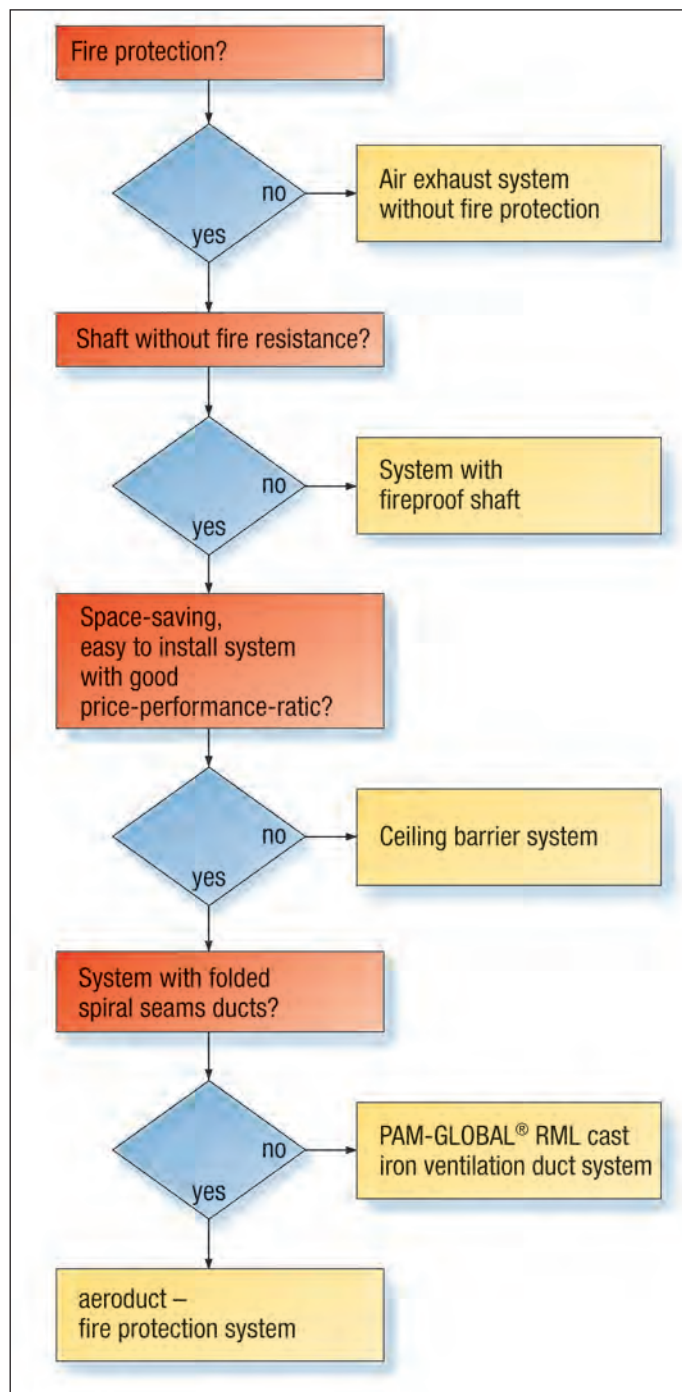

If you have selected a system, select the fan you need. Proceed as follows:

- Define the volumetric flow of exhaust air required. You will find guide values and layout examples in the “Planning instructions” section.
- Select the fan size on the basis of this volumetric flow. MAICO supplies fans with a volumetric flow of 60 m³/h or 100 m³/h.
- Select the type of fan installation according to the building requirements: Surface-mounted or recessed.
- Select one of the possible models for the fan.

aeroduct fire protection system

Application areas

- Bathrooms, WCs and domestic kitchens

Constructional requirements:

- Non-fire-proof installation shaft
- Shaft wall made of plaster board, 12.5 mm thick
- Ceiling compound 100 mm
- Maximum floor height 3.5 m

Approval:

- General official approval
- Approval number Z-41.6-573 (approval only in conjunction with MAICO fans)
- Fire resistance class K90-18017 S

Functional description

The aeroduct fire protection system in case of fire

- The shut-off devices for MAICO fans close automatically in the event of a fire.
- The heat expands the main duct towards the ceiling and this moves the fire protection compensation element upwards.
- Consequently the roof does not come under stress, and cracks are avoided in the ceiling.
- The fire protection insulation shields the combustible materials in the insulation shaft from heat. A separating bridge is then superfluous.

PAM Global RML fire protection system

Application areas

- Bathrooms and WCs

Constructional requirements

- Non-fire-proof installation shaft
- Shaft wall made of plaster board, 12.5 mm thick
- Ceiling compound 150 mm

Approval

- General official approval
- Approval number Z-41.6-693
- Fire resistance class K90-18017 S

Functional description

The PAM-GLOBAL RML cast iron ventilation duct system in case of fire

- The shut-off devices of the MAICO fans close automatically in the event of a fire.
- The cast iron pipe is able to withstand fire.
- The ISOVER ULTIMATE U TFA 34 insulation shields the combustible materials in the installation shaft. A separating bridge is then superfluous.
- The BI fire protection insulation from MAICO cannot be used.

Contact address

For further information on PAM-GLOBAL RML ducts and shaped elements, please visit www.saint-gobain-hes.de or contact:
Saint-Gobain HES GmbH - Ettore-Bugatti-Straße 35 -
51149 Köln/Porz-Gremberghoven - Deutschland
Phone: +49 2203 / 97 84-0 - Fax: +49 2203 / 97 84-200

Ceiling barrier fire protection system

Application areas

- Bathrooms, WC's and domestic kitchens

Constructional requirements

- Non-fire-proof installation shaft
- Ceiling compound 100 mm

Approval

- General official approval
- Approval number Z-41.3-556
- Fire resistance class K90-18017

Functional description

The ceiling barrier system in case of fire

- The TS 18 fire protection ceiling barrier consists of a housing in which several lamella with pressure springs should close off the cross section. A synthetic insert alongside the housing wall prevents the lamella from closing. The housing wall is covered with temperature dependent expanding foam material.
- The synthetic insert becomes soft in case of fire.
- The springs press the lamella together and these mechanically close the main duct.
- The temperature dependent expanding foam material expands and closes the main duct.
- Fire protection devices on the fans are unnecessary here.

Fire protection system with fire-proof shaft

Application areas

- Bathrooms, WC's and apartment kitchens

Constructional requirements

- Fire-proof installation shaft
- Ceiling compound 100 mm

Functional description

System with fire-proof shaft in the case of fire

- The shut-off devices of the MAICO fans close automatically in the event of a fire.
- The fire-proof housings are fitted in the wall of the fire-proof installation shaft. They prevent fire and smoke from spreading.

Air extraction system without fire protection

Application areas

- Bathrooms, WC's and domestic kitchens

Constructional requirements

- No fire protection requirements
- Ceiling compound recommended

Accessories for fire protection systems

Fire protection compensation elements BA



- Can only be used in combination with the aeroduct fire protection system.
- Fire protection compensating element: T-piece and compensator at the same time. Delivering fire protection without extra mounting work.
- In case of fire the fire protection compensation element guarantees that no significant force will be exerted on the ventilation duct.
- BA fire protection compensation element without connection couplings, for use when bridging floors where no fans have to be connected, or when re-routing the main duct.
- Continuous cross section of the main duct for easy duct cleaning.
- General official approval, approval number Z-41.6-573 (approval only in conjunction with MAICO fans).
- Selectable with 0, 1 or 2 connection couplings.
- Fire resistance class K90-18017 S.
- Accessories needed: BI fire protection insulation.

Dimensions [mm]

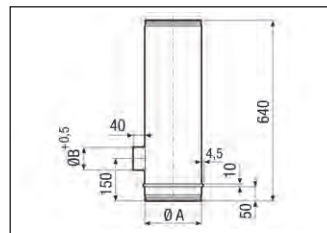

Common features

Material	Sheet steel
Air direction	Air extraction
Fire protection	yes

Article	Art. No.	Nominal size mm	Number of couplings
BA 100-0	0093.1019	100	0
BA 125-0	0093.1020	125	0
BA 160-0	0093.1021	160	0
BA 200-0	0093.1022	200	0
BA 100/80-1	0093.1000	100	1
BA 125/80-1	0093.1001	125	1
BA 160/80-1	0093.1002	160	1
BA 200/80-1	0093.1003	200	1
BA 100/80-2	0093.1004	100	2
BA 125/80-2	0093.1005	125	2
BA 160/80-2	0093.1006	160	2
BA 200/80-2	0093.1007	200	2
BA 125/100-1	0093.1008	125	1
BA 160/100-1	0093.1009	160	1

Article	A mm	B mm
BA 100-0	100	-
BA 125-0	125	-
BA 160-0	160	-
BA 200-0	200	-
BA 100/80-1	100	81
BA 125/80-1	125	81
BA 160/80-1	160	81
BA 200/80-1	200	81
BA 100/80-2	100	81
BA 125/80-2	125	81
BA 160/80-2	160	81
BA 200/80-2	200	81
BA 125/100-1	125	101
BA 160/100-1	160	101

Fire protection insulation BI



- Must be combined with the aeroduct fire protection system.
- With tubular sound absorbers made from rock wool, covered with non-tearing aluminium foil.
- Non-combustible in accordance with DIN 4102 class A2 (building material classification).
- No cancer causing agents, in accordance with EU directive 97/69/EC and Dangerous Materials Ordinance Appendix V, No. 7.1(1).
- Safe processing through high biological capabilities.
- Water-repellent, water absorption < 10 % volume.
- Only complete packing units will be delivered.
- Accessory needed for BA fire protection compensation element.

Common features

Material	Rock wool
Length	1 m
Duct shell thickness	40 mm
Fire protection	yes

Article	Art. No.	Nominal size mm	Packing unit
BI 100	0092.0395	100	3 x 1 m piece
BI 125	0092.0396	125	3 x 1 m piece
BI 160	0092.0397	160	1 x 1 m piece
BI 200	0092.0398	200	1 x 1 m piece

Fire protection ceiling barriers TS 18



- Fire protection ceiling barrier for ER exhaust air systems.
- With continuous open cross-section and smooth inner surfaces.
- General official approval, approval number Z-41.3-556.
- Certificate of approval at www.maico-fans.com.
- Fire resistance class K90-18017.
- Maintenance-free.

Dimensions [mm]

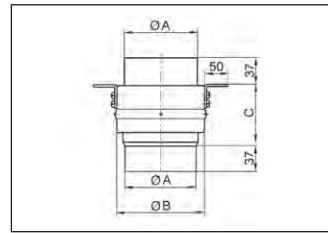

Common features

Material	Sheet steel
Installation site	Ceiling
Air direction	Ventilation and air extraction
Fire protection	yes

Article	Art. No.	Nominal size mm
TS 18 DN 100	0151.0320	100
TS 18 DN 125	0151.0321	125
TS 18 DN 140	0151.0322	140
TS 18 DN 160	0151.0323	160
TS 18 DN 180	0151.0324	180
TS 18 DN 200	0151.0325	200

Article	A mm	B mm	C mm
TS 18 DN 100	99	126	78
TS 18 DN 125	124	156	88
TS 18 DN 140	139	173	93
TS 18 DN 160	159	195	106
TS 18 DN 180	179	220	116
TS 18 DN 200	199	242	128

Flexible aluminium ducts AFR



- Flexible five-layered, grooved aluminium duct to be used as connecting duct to the main duct, in accordance with DIN 18017-3.
- Non-combustible in accordance with DIN 4102 class A1 (building material classification).
- Length details: extended length.

Common features

Material	Aluminium
Max. operating pressure	2,500 Pa
Max. ambient temperature	100 °C

Article	Art. No.	Nominal size mm	Length mm
AFR 75	0055.0088	75	3
AFR 80	0055.0092	80	3
AFR 100	0055.0090	100	10
AFR 125	0055.0091	125	10
AFR 150	0055.0093	150	10

Flexible steel duct SFR 80

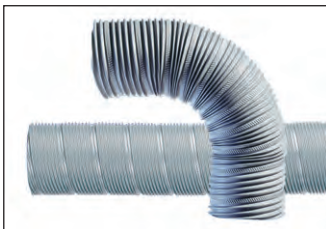

- Flexible single-grooved folded spiral-seams duct made of galvanised sheet steel to be used as connection to the main duct, in accordance with DIN 18017-3.
- Application of flexible steel ducts when using the aeroduct fire protection systems, in accordance with the general official approval Z-41.6-573.
- Non-combustible in accordance with DIN 4102 class A1 (building material classification).
- Length details: extended length.

Features

Nominal size	80 mm
Material	Sheet steel
Length	1.2 m

Article	Art. No.
SFR 80	0055.0072

Single air extraction system ER EC / recessed-mounted housing ER GH



Single room air extraction

- New product, available from 4th quarter of 2017.
- Installation in bathrooms, WC's and domestic kitchens.
- Convertible plastic exhaust socket with airstream-operated plastic backflow preventer.
- For air outlet direction at side and rear.
- Installation inside and outside the wall and ceiling shafts is possible.
- Reduced overall depth of the recessed housing and the cover.
- There are 6 mounting grooves on the side of the housing as mounting aids.
- Electrical connection possible at side or rear.
- For air outlet direction to top, right, left or rear.
- DN 75/80 connection diameter.
- Plastic parts are normally inflammable in accordance with class B 2.
- With plaster protective cover.
- National technical approval.
- Certificates of approval on request or on our website - www.maico-fans.com.
- ER-AS extraction socket for WC seat ventilation.
- A knockout point is provided at the bottom in the ER GH housing for the additional WC connection socket.

Exhaust air system	Installable	Note
aero-duct fire protection system	No	-
PAM-Global RML cast iron ventilation system	No	-
Ceiling barrier system	Yes	within and outside the shaft, connection duct with flexible aluminium duct
System with fire-proof shaft	No	-
Air extraction system without fire protection	Yes	within and outside the shaft, connection duct with flexible aluminium duct

Article	Art. No.
ER GH	0084.0350

Dimensions [mm]

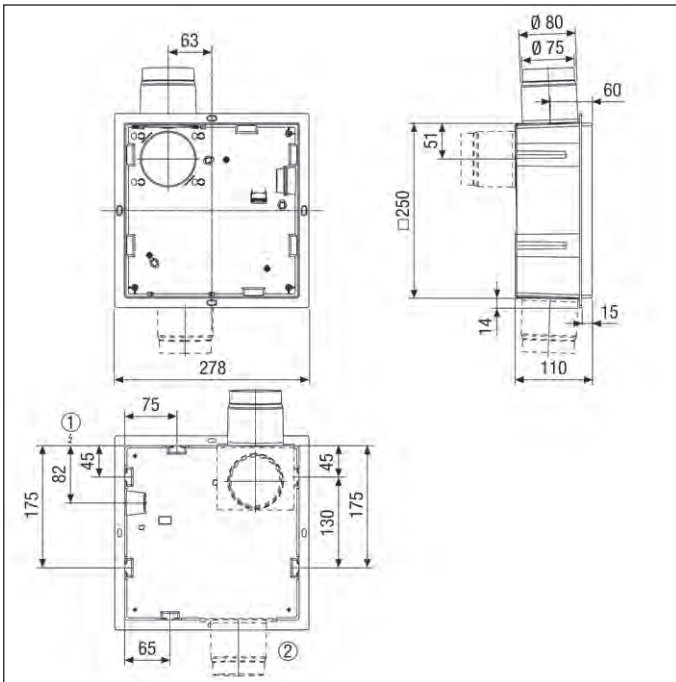

① Electrical connection
 ② WC connection socket

Important accessories

Fan insert



P. 52

ER EC fan insert for ER GH recessed-mounted housing, air volume of 30 m³/h / 60 m³/h

ER EC 0084.0360

Covers



P. 54

Covers for ER EC fan insert

ER-A 0084.0361
 ER-AK 0084.0362
 ER-AH 0084.0363
 ER-AB 0084.0364

Dimensions [mm]

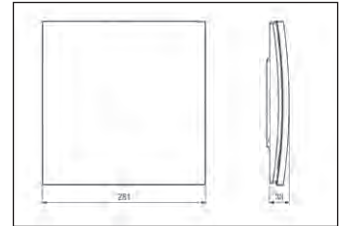

Mounting support



P. 56

Mounting support for ER GH and ER-UP.. recessed-mounted housing

UPM 60/100 0018.0010

Dimensions [mm]

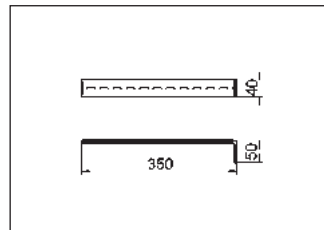

Air extraction socket



P. 56

Extraction socket for toilet seat ventilation, for combination with ER GH and ER-UP.. recessed-mounting housings

ER-AS 0093.0928

Dimensions [mm]

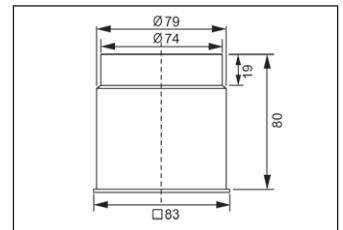

Sponge rubber set



P. 56

Sponge rubber set for the sound insulation of ER GH, ER-UP/G and ER-UPD recessed-mounted housing, length is enough for 2 housings

ER-MO 0092.0361

Installation kit

P. 57

Installation kit for ER GH recessed-mounted housing, comprising hammer head screw with nut and 90° bracket

ER-MS 0093.0603

Single air extraction system ER EC / fan insert ER EC



Features

- New product, available from 4th quarter of 2017.
- 2-level fan for installing in ER GH recessed-mounted housing.
- Air volume of 30 m³/h, 60 m³/h (20 / 40 / 100 m³/h also possible if combined with an intelligent cover).
- Start delay 60 s.
- Overrun time 15 min.
- For single room air extraction using a single fan.
- Electrical plug connection for quick fan installation in the housing.
- Trouble-free filter change without using tools.
- It is possible to rotate the cover by ± 5°, to compensate for housings which have been fitted at an angle.
- The housing has easy to install snap-in fan fittings.
- All MAICO ER units have an IP X5 degree of protection and can be installed in area 1 in accordance with DIN VDE 0100-701, even with water jets. For details see planning instructions.
- Protection class II.
- The steep characteristic curve shows the high pressure capacity of the ER EC fan.
- Robust energy-saving EC motor.
- Motor with thermal overload protection.
- Maintenance-free, with enclosed ball bearings on both sides.

Technical data

Article	Art. No.	U _{nom} V	f _{nom} Hz	Rotating speed 1/min	Air flow volume m ³ /h	Power consumption W	T _{max} at I _{max} °C	Sound pressure level dB(A)	Sound power level L _{WA7} dB(A)	Filter class	Degree of protection IP	Mains cable mm ²
ER EC	0084.0360	230	50	800/1,250 ¹⁾	30/60 ¹⁾	3/6 ¹⁾	40	26/36 ¹⁾	30/40 ¹⁾	G2	X5	4 x 1.5

¹⁾ In accordance with factory setting in combination with ER-A, ER-AK, ER-AH or ER-AB cover, for values for covers with intelligent control module, see ER-AK, ER-AH and ER-AB product pages 54.

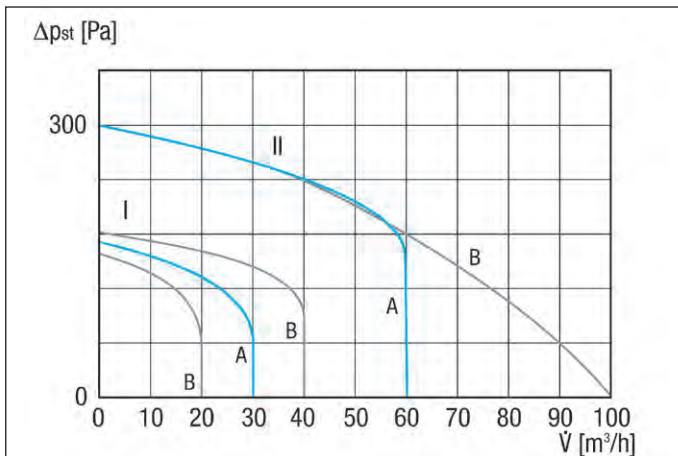

Characteristic curve ER EC

- Ⓐ Factory settings for basic and nominal load level in conjunction with ER-A cover
 Ⓑ Alternative settings for basic and nominal load levels in conjunction with ER-AK/...-AH/...-AB covers

Important accessories
Recessed-mounted housing

P. 50

Recessed-mounted housing with convertible plastic socket to hold the ER EC fan insert, second connection possible for toilet seat ventilation
 ER GH 0084.0350

Dimensions [mm]

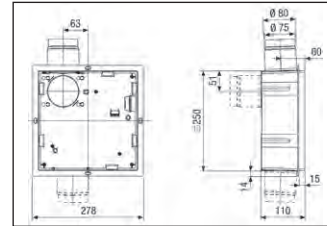

Covers

P. 54

Covers for ER EC fan insert

ER-A 0084.0361
 ER-AK 0084.0362
 ER-AH 0084.0363
 ER-AB 0084.0364

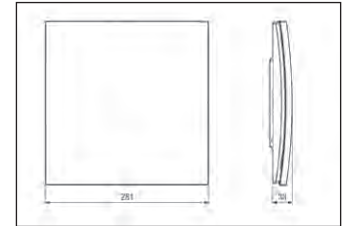
Dimensions [mm]



Outside air openings

P. 309

Outside air openings for draught-free fresh air supply using outside air

ALD 125 0152.0067
 ALD 125 VA 0152.0068

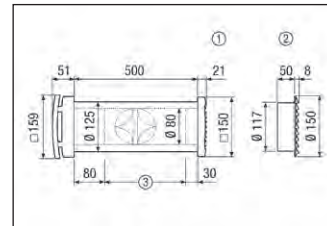
Dimensions [mm]



- ① Rectangular plastic external grille
 ALD 125
 ② Round stainless steel external grille
 ALD 125 VA
 ③ Shorten to wall thickness if required

Door ventilation grilles

P. 312

Door ventilation grille for bathroom, WC or kitchen

MLK 30 white 0151.0123
 MLK 45 white 0151.0126

Accessories selection table

	ER EC	see
Recessed-mounted housing	ER GH	P. 50
Cover	ER-A ER-AK ER-AH ER-AB	P. 54
Outside air opening	ALD 10 ALD 125 ALD 125 VA ALD 160 ALD 160 VA	P. 308
Roof outlet	DF	P. 306
Roofing tile	DP	P. 306
Mounting clamp	BS	P. 306
Rain protection grille	RG	P. 306
Door ventilation grille	MLK 30 white MLK 45 white	P. 312
Flexible aluminium duct	AFR 75 AFR 80	P. 319



Models

- ER-A: Standard model.
- ER-AK: Comfort version with intelligent time module.
- ER-AH: Model with humidity control and intelligent time module.
- ER-AB: Model with motion detector and intelligent time module.

Features

- New product, available from 4th quarter 2017.
- Contemporary design.
- Suitable for continuous operation.
- IP X5 degree of protection for safety in the bathroom.
- Colour: traffic white, similar to RAL 9016.

- For single room air extraction using a single fan.
- With filter change display.
- Trouble-free filter change without using tools.
- It is possible to rotate the cover by $\pm 5^\circ$, to compensate for housings which have been fitted at an angle.
- Protection class II.
- Energy-saving EC motor.
- Motor with thermal overload protection.
- Maintenance-free, with enclosed ball bearings on both sides.

The following models are available:

ER-A – Standard model

- Standard cover with filter change display.
- Not speed-controllable.
- The unit runs in continuous operation at the base load level at 30 m³/h.
- Full load level on/off via light switch or separate switch.
- Switching to full load level (60 m³/h) with start delay of approx. 60 sec.
- Full load overrun time approx. 15 min.
- Switching option: The base load can be switched on or off by an additional switch (see the wiring diagrams online).

- Adjustable overrun time of the full load level (0/3/6/15*/24/30 min).
- Adjustable interval control for ventilating rooms that are not regularly used.
- Adjustable time interval (0*/1/2/4/6/12 h).
- Approx. 10 min. operating time per interval.
- During manual operation (e.g. using light switch), the set start delay and overrun time apply.
- Interval control can be switched off.
- Switching option: The base load can be switched on or off by an additional switch (see the wiring diagrams online).

- Full load level on/off via light switch or separate switch.
- Switching to full load level (60 m³/h) with adjustable start delay (0/30/60*/90/120 sec).
- Adjustable overrun time of the full load level (0/3/6/15*/24/30 min).
- Adjustable interval control for ventilating rooms that are not regularly used.
- Time interval adjustable (1*/2/4/6/12 h).
- Approx. 10 min. operating time per interval.
- During manual operation (e.g. using light switch), the set start delay and overrun time apply.
- Interval control can be switched off.
- Intelligent humidity control.
- Switch-on humidity does not have to be set. Fan independently monitors the room air humidity and extracts air automatically.

- Capacitive operating level.
- Electric plug connection for quickly connecting cover with fan.
- The unit runs in continuous operation at the base load level at 30 m³/h.
- Full load level on/off via light switch or separate switch.
- Switching to full load level (60 m³/h) with adjustable start delay (0/30/60*/90/120 sec).
- Adjustable overrun time of the full load level (0/3/6/15*/24/30 min).
- Adjustable interval control for ventilating rooms that are not regularly used.
- Time interval adjustable (1*/2/4/6/12 h).
- Approx. 10 min. operating time per interval.
- During manual operation (e.g. using light switch), the set start delay and overrun time apply.
- Interval control can be switched off.
- Control via motion detector. After motion is detected, the full load level is activated.
- Effective range of the motion detector: 5 m.

ER-AK – comfort version with intelligent time module

- Cover with intelligent time module and LED filter change display.
- Not speed-controllable.
- Other air volumes of 20 m³/h, 40 m³/h, 100 m³/h can be set.
- Capacitive operating level.
- Electric plug connection for quickly connecting cover with fan.
- The unit runs in continuous operation at the base load level at 30 m³/h.
- Full load level on/off via light switch or separate switch.
- Switching to full load level (60 m³/h) with adjustable start delay (0/30/60*/90/120 sec).

ER-AH – model with intelligent time module and humidity control

- Cover with humidity control, intelligent time module and LED filter change display.
- Barrier-free product as the fan switches itself on and off automatically.
- Not speed-controllable.
- Other air volumes of 20 m³/h, 40 m³/h, 100 m³/h can be set.
- Capacitive operating level.
- Electric plug connection for quickly connecting cover with fan.
- The unit runs in continuous operation at the base load level at 30 m³/h.

ER-AB - model with motion detector and intelligent time module

- Cover with motion detector, intelligent time module and LED filter change display.
- Barrier-free product as the fan switches itself on and off automatically.
- Not speed-controllable.
- Other air volumes of 20 m³/h, 40 m³/h, 100 m³/h can be set.

*Factory settings

Technical data

Article	Art. No.	Model	U _{nom}	f _{nom}	Rotating speed	Air flow volume	Power consumption	T _{max} at I _{max}	Sound pressure level	Sound power level L _{WA7}	Filter class	Degree of protection IP	Mains cable mm ²
			V	Hz	1/min	m ³ /h	W	°C	dB(A)	dB(A)			
ER-A	0084.0361	Standard	230	50	800/1,250	30/60	3/6	40	26/36 ¹⁾	30/40	G2	X5	4 x 1.5
ER-AK	0084.0362	Comfort with intelligent time module	230	50	500/800/1,050/1,250/1,800	20/30/40/60/100	2/3/4/6/14	40	22/26/31/36/45 ¹⁾	26/30/35/40/49	G2	X5	4 x 1.5
ER-AH	0084.0363	Humidity control with intelligent time module	230	50	500/800/1,050/1,250/1,800	20/30/40/60/100	2/3/4/6/14	40	22/26/31/36/45 ¹⁾	26/30/35/40/49	G2	X5	4 x 1.5
ER-AB	0084.0364	Motion detector with intelligent time module	230	50	500/800/1,050/1,250/1,800	20/30/40/60/100	2/3/4/6/14	40	22/26/31/36/45 ¹⁾	26/30/35/40/49	G2	X5	5 x 1.5

¹⁾ Specifications in accordance with DIN 18017-3 at an equivalent absorption area A_{eq} = 10 m²

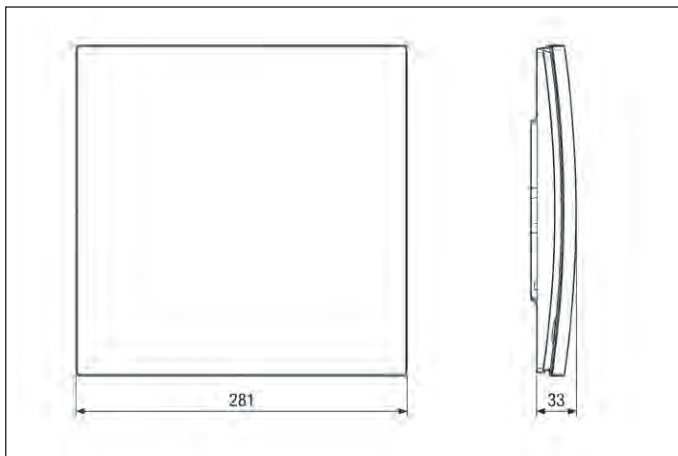
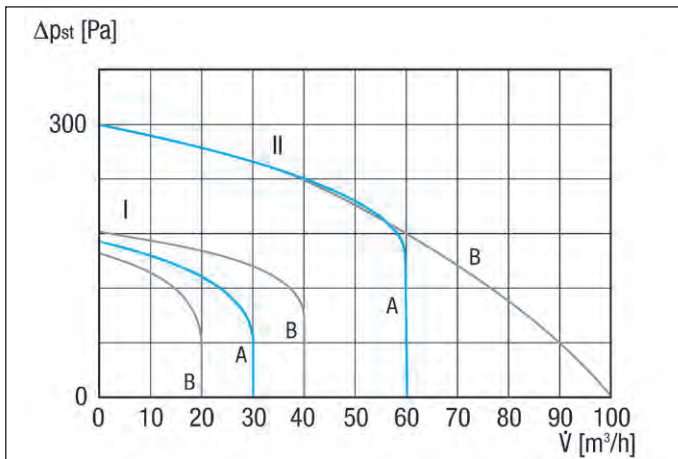
Dimensions [mm]

Characteristic curve ER EC

Ⓐ Factory settings for basic and nominal load level in conjunction with ER-A cover

Ⓑ Alternative settings for basic and nominal load levels in conjunction with ER-AK/...-AH/...-AB covers

Important accessories
Recessed-mounted housing

P. 50

 Recessed-mounted housing with convertible plastic socket to hold the ER EC fan insert, second connection possible for toilet seat ventilation
 ER GH 0084.0350

Fan insert

P. 52

ER EC fan insert for ER GH recessed-mounted housing, air volume of 30 m³/h / 60 m³/h

ER EC 0084.0360

Dimensions [mm]

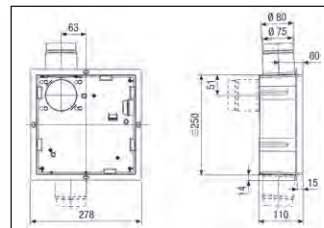
Air filters, replacement
P. 57

Replacement air filter for the covers of the ER EC fan insert

 ZF EC 0093.0758
 ZF EC bulk container 0093.0759
 ZF EC+ 0093.0610
 ZF EC+ bulk container 0093.0611

Accessories selection table

	ER-A	ER-AK	ER-AH	ER-AB	see
Recessed-mounted housing	ER GH	ER GH	ER GH	ER GH	P. 50
Fan insert	ER EC	ER EC	ER EC	ER EC	P. 52
Air filter, replacement	ZF EC+ ZF EC+ bulk container	ZF EC ZF EC bulk container	ZF EC ZF EC bulk container	ZF EC ZF EC bulk container	P. 57
Radio switch	XS 1	-	-	-	P. 350
Radio receiver	XE 1	-	-	-	P. 350
Time delay switch	VZ 6 VZ 12 VZ 24 C	-	-	-	P. 342
Interval switch	VZI 10	-	-	-	P. 342
Timer	ZS 4	-	-	-	P. 343
Hygrostat	HY 230 HY 230 I	-	-	-	P. 348

Accessories for single air extraction system ER EC



Mounting support UPM 60/100

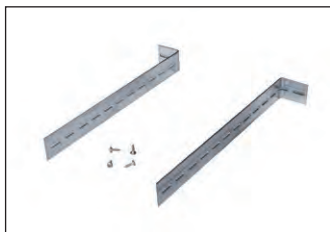

- Mounting support for installation of ER-GH and ER-UP.. recessed-mounted housing on walls, ceilings or in shafts.
- With slots for precise adjustment of the fan housing.
- Packing unit:
 - 2 L-shaped angle plates
 - 4 mounting screws.

Dimensions [mm]

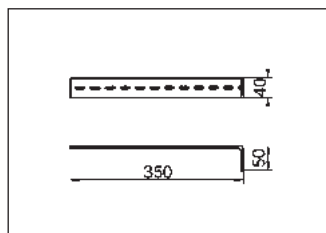

Features

Material	Sheet steel
----------	-------------

Article	Art. No.
UPM 60/100	0018.0010

Air extraction socket ER-AS



- Extraction socket for ER GH, ER-UPD and ER-UP/G recessed-mounted housing for toilet seat air extraction. Air extraction of room and WC seat at the same time.
- Pre-requirements: The flushing pipe from the recessed-mounted toilet cistern is fitted with a DN 70 branch.
- Connection from flushing pipe to the fan HT DN 70, resulting in reduced air speeds and effective, draught-free extraction.
- Combination with ER EC, ER 60 or ER 100.
- Cistern recommendation: Manufacturer TECE, TECEprofil Universal module for WC with TECE cistern with connection for odour extraction. TECE Order no.: 9.300.003, www.tece.de, Tel.: +49 (0) 25 72 / 928-0

Dimensions [mm]

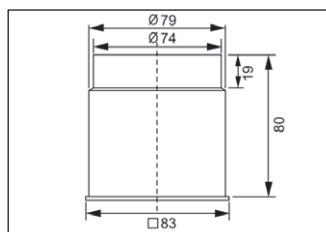

Features

Material	Synthetic material
Colour	Black
Installation site	Wall
Max. ambient temperature	60 °C
Air direction	Air extraction

Article	Art. No.
ER-AS	0093.0928

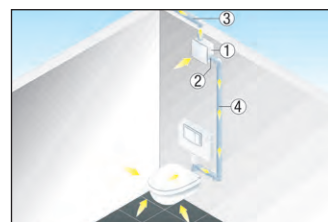

- ① Recessed-mounted housing ER-UP/G with Centro M
- ② ER-AS extraction socket
- ③ Connection to exhaust air duct network:
 - with AFR 80 aluminium flexible duct for duct network made of folded spiral-seams duct or
 - with MF-F90 flexible duct without transition piece or
 - with 90° MF-B75 steel elbow or MF-FSM75 connector on MF-F75 flexible duct
- ④ DN 70 HT duct

Sponge rubber set ER-MO



- Sponge rubber set for the sound insulation of ER GH, ER-UP/G and ER-UPD recessed housings, when used with highly resonant thin ceilings or walls.
- **Length is enough for 2 housings.**

Features

Material	Synthetic material
Length	2.2 m

Article	Art. No.
ER-MO	0092.0361

**Air filters, replacement
ZF EC**

Article	Art. No.	Packing unit
ZF EC	0093.0758	5 pieces
ZF EC	0093.0759	100 pieces
bulk container		
ZF EC+	0093.0610	5 pieces
ZF EC+	0093.0611	100 pieces
bulk container		

- ZF EC replacement air filter for the ER-AK/-AH/-AB covers of the ER EC fan insert.
- ZF EC+ replacement air filter with filter change display for the ER-A cover of the ER fan insert.
- New product, available from 4th quarter of 2017.

Common features

Filter class	G2
Max. ambient temperature	40 °C

**Installation kit
ER-MS**

Article	Art. No.
ER-MS	0093.0603

- New product, available from 4th quarter of 2017.
- Installation kit for ER GH recessed-mounted housing, comprising hammer head screw with nut and 90° bracket.

Features

Material	Steel, galvanised
----------	-------------------

ER single air extraction system resp. Centro centralised ventilation system / ER-UP/G recessed-mounted housing



Single room air extraction

- Installation in bathrooms, WCs and domestic kitchens.
- Plastic exhaust socket with airstream-operated plastic backflow preventer.
- Installation inside and outside the wall and ceiling shafts is possible.
- Reduced overall depth of the recessed housing and the cover.
- Approved for upward, right-hand or left-hand air outlet directions.
- DN 75/80 connection diameter.
- Synthetic material parts are normally inflammable in accordance with class B 2 (building material classification).
- With plaster protective cover.
- General official approval, approval no.: Z-51.1-7.
- Certificates of approval on request or on our website - www.maico-fans.com.

Second room air extraction

- ER-ZR second room connection kit for second room air extraction.
- Knockout points for the additional connection socket on the right, left and lower side have been fitted in the ER-UP/G housing.
- Fan types which can be used for second room ventilation in accordance with DIN 18017-3: ER 100, ER 100 VZ, ER 100 VZ 15, ER 100 VZC, ER 100 G, ER 100 I, ER 100 D or ER 100 RC.
- Main room: 60 m³/h
- Second room: 40 m³/h

Exhaust air system	Installable	Note
aeroduct fire protection system	No	-
PAM-GLOBAL L cast iron ventilation system	No	-
Ceiling barrier system	Yes	within and outside the shaft, connecting duct with flexible aluminium duct, second room connection with flexible aluminium duct
System with fire-proof shaft	No	-
Air extraction system without fire protection	Yes	within and outside the shaft, connecting duct with flexible aluminium duct, second room connection with flexible aluminium duct

Article	Art. No.	Model
ER - UP/G	0093.0995	Plastic exhaust socket with airstream-operated plastic backflow preventer, without fire protection housing, second room connection possible on right/left/at bottom

ER single air extraction system resp. Centro centralised ventilation system / ER-UP/G recessed-mounted housing

Dimensions [mm]

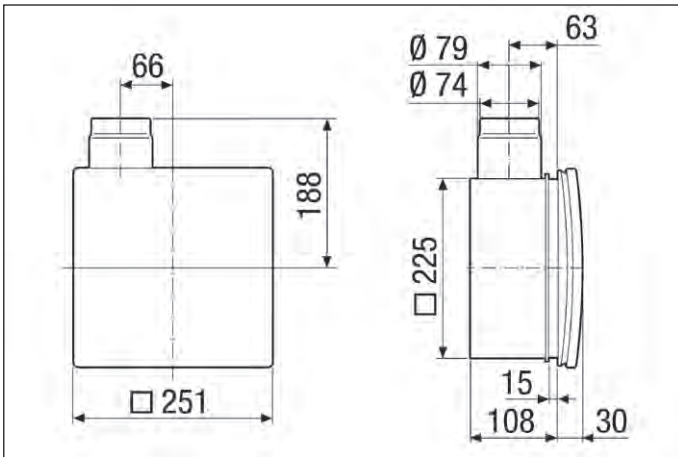

Dimensions [mm]

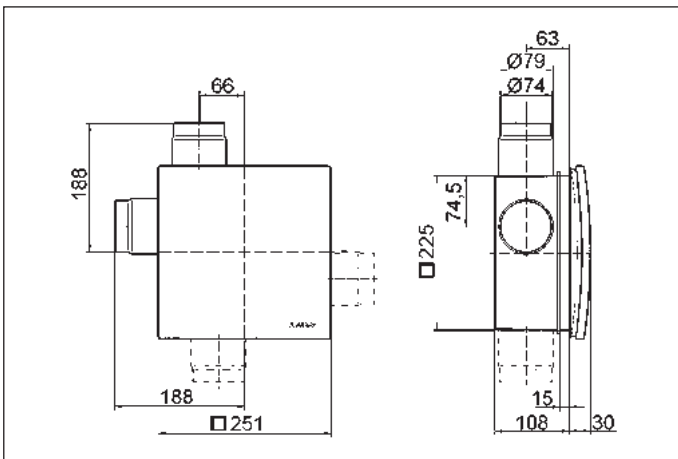

ER-UP/G with second room connection

Important accessories

Fan inserts



P. 66

Fan insert ER 60./ ER 100.. for ER-UP .. recessed-mounted housing

ER 60 0084.0100
ER 100 0084.0130

For other models, see page 68.

Spacing frame



P. 64

Spacing frame for ER-UP..recessed-mounted housings that have been plastered too deep

DR 60/100 0059.0928

Mounting support



P. 64

Mounting support for ER GH and ER-UP.. recessed-mounted housing

UPM 60/100 0018.0010

Dimensions [mm]

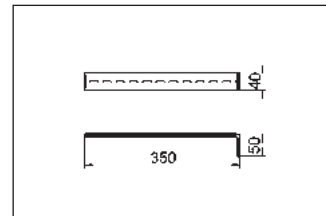

Masking frame



P. 64

Masking frame for ER-UP.. recessed-mounted housing with excess joint gap

ER-AR 0059.0899

Dimensions [mm]

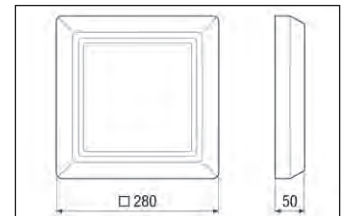

Wall frame



P. 64

Wall frames for housings that have been plastered too deep, to prevent the air from being drawn out of the shaft, sheet steel

ER-MR 0018.0024

Second room extraction system



P. 65

Second room connection kit for combination with ER 100.. fan insert

ER-ZR 0093.1025

Dimensions [mm]

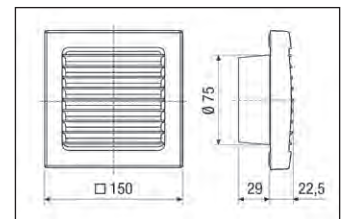

Air extraction socket



P. 65

Extraction socket for toilet seat ventilation, for combination with ER GH and ER-UP.. recessed-mounting housings

ER-AS 0093.0928

Dimensions [mm]

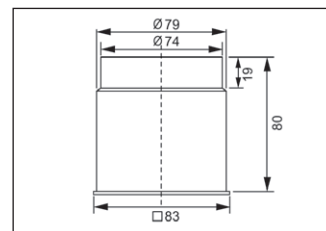

Sponge rubber set



P. 65

Sponge rubber set for the sound insulation of ER GH, ER-UP/G and ER-UPD recessed-mounted housing, length is enough for 2 housings

ER-MO 0092.0361

ER single air extraction system resp. Centro centralised ventilation system / ER-UPD recessed-mounted housing



Single room air extraction

- Recessed-mounted housings for fitting an ER 60 or ER 100 fan.
- With K90-18017 maintenance-free fire protection shut-off device against spread of fire.
- DN 75/80 metal exhaust socket with metal shut-off device with airstream-operated release mechanism.
- For installation in domestic kitchens, bathrooms and WCs.
- Installation inside and outside the wall and ceiling shafts is possible.
- Reduced overall depth of the recessed housing and the cover.
- Approved for upward, right-hand or left-hand air outlet directions.
- Simple to remove backflow preventer, which ensures easy and quick cleaning.
- Synthetic material parts are normally inflammable in accordance with class B 2 (building material classification).
- With plaster protective cover.
- General official approval, approval no.: Z-51.1-46.
- Certificates of approval on request or on our website - www.maico-fans.com.

Second room air extraction

- ER-ZR second room connection kit for second room air extraction.
- Knockout points for the additional connection socket on the right, left and lower side have been fitted in the ER-UPD housing.
- Fan types which can be used for second room ventilation in accordance with DIN 18017-3: ER 100, ER 100 VZ, ER 100 VZ 15, ER 100 VZC, ER 100 G, ER 100 I, ER 100 D or ER 100 RC.
- Main room: 60 m³/h
- Second room: 40 m³/h

Exhaust air system	installable	Note
aeroduct fire protection system	yes	within and outside the shaft, connecting duct with flexible steel duct, second room connection with flexible aluminium duct
PAM-GLOBAL RML cast ventilation system	yes	within and outside the shaft, connecting duct with flexible steel duct, second room connection with flexible aluminium duct
Ceiling barrier system	yes	not mandatory
System with fire-proof shaft	yes	outside the shaft, connecting duct with flexible steel duct, second room connection with flexible aluminium duct
Air extraction system without fire protection	yes	not mandatory

Article	Art. No.	Model
ER - UPD	0093.0972	Metal exhaust socket with metal shut-off shutter, with airstream-operated triggering device, without fire protection housing, second room connection possible on right/left/at bottom

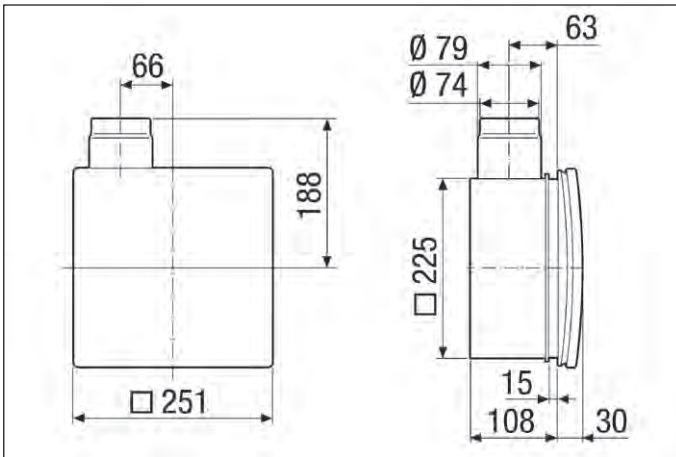
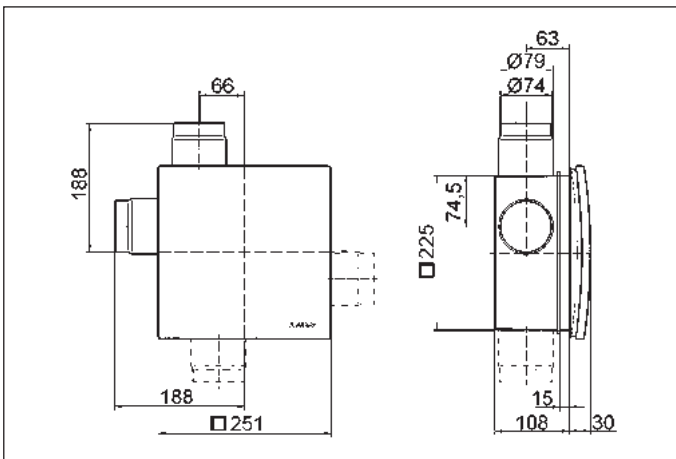
ER single air extraction system resp. Centro centralised ventilation system / ER-UPD recessed-mounted housing
Dimensions [mm]

Dimensions [mm]

ER-UPD with second room connection

Important accessories
Fan inserts

P. 66

Fan insert ER 60./ ER 100.. for ER-UP .. recessed-mounted housing

 ER 60 0084.0100
 ER 100 0084.0130

For other models, see page 68.

Spacing frame

P. 64

Spacing frame for ER-UP..recessed-mounted housings that have been plastered too deep

DR 60/100 0059.0928

Mounting support

P. 64

Mounting support for ER GH and ER-UP.. recessed-mounted housing

UPM 60/100 0018.0010

Masking frame

P. 64

Masking frame for ER-UP.. recessed-mounted housing with excess joint gap

ER-AR 0059.0899

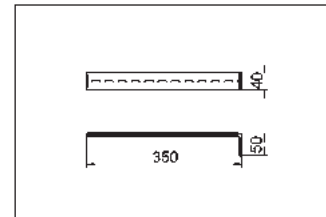
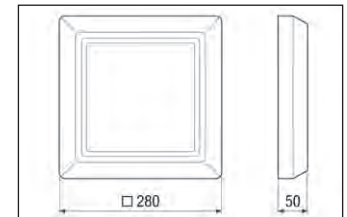
Dimensions [mm]

Dimensions [mm]

Wall frame

P. 64

Wall frames for housings that have been plastered too deep, to prevent the air from being drawn out of the shaft, sheet steel

ER-MR 0018.0024

Second room extraction system

P. 65

Second room connection kit for combination with ER 100.. fan insert

ER-ZR 0093.1025

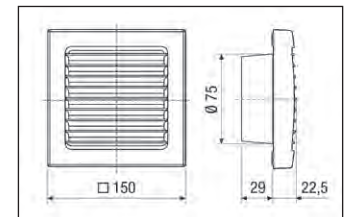
Dimensions [mm]

Air extraction socket

P. 65

Extraction socket for toilet seat ventilation, for combination with ER GH and ER-UP.. recessed-mounting housings

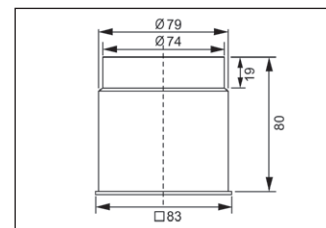
ER-AS 0093.0928

Dimensions [mm]

Sponge rubber set

P. 65

Sponge rubber set for the sound insulation of ER GH, ER-UP/G and ER-UPD recessed-mounted housing, length is enough for 2 housings

ER-MO 0092.0361

ER single air extraction system resp. Centro centralised ventilation system / ER-UPB recessed-mounted housing



Single room air extraction

- Fire-proof housings for fitting an ER 60 or ER 100 fan.
- With K90-18017 maintenance-free fire protection shut-off device against spread of fire.
- DN 75/80 metal exhaust socket with metal shut-off device with airstream-operated release mechanism.
- For installation in domestic kitchens, bathrooms and WCs.
- Simple to remove backflow preventer, which ensures easy and quick cleaning.
- Reduced overall depth of the recessed housing and the cover.
- With plaster protective cover.
- General official approval, approval no.: Z-51.1-46.
- Certificates of approval on request or on our website - www.maico-fans.com.
- Approved for wall installation with upward, right-hand or left-hand air outlet directions, as well as ceiling installation.

Second room air extraction

- ER-UPB housings with integrated second room connection kit can be supplied for second room air extraction:
 - UPB/R : right.
 - UPB/L : left.
 - UPB/U : bottom.
- Fan types which can be used for second room ventilation in accordance with DIN 18017-3: ER 100, ER 100 VZ, ER 100 VZ 15, ER 100 VZC, ER 100 G, ER 100 I, ER 100 D or ER 100 RC.
- Main room: 60 m³/h
- Second room: 40 m³/h

Exhaust air system	installable	Note
aeroduct fire protection system	no	-
PAM-GLOBAL RML cast ventilation system with fire-proof shaft	yes	within the shaft, connecting duct with flexible aluminium duct, second room connection with flexible steel duct
Ceiling barrier system	yes	not mandatory
System with fire-proof shaft	yes	inside and outside the shaft, Connecting duct with flexible aluminium duct, second room connection with flexible steel duct
Air extraction system without fire protection	yes	not mandatory

Article	Art. No.	Model
ER - UPB	0093.0968	Metal exhaust socket with metal shut-off shutter, with airstream-operated triggering device, with fire protection housing, no second room connection possible.
ER - UPB/R	0093.0969	Metal exhaust socket with metal shut-off shutter, with airstream-operated triggering device, with fire protection housing, second room connection on right
ER - UPB/L	0093.0970	Metal exhaust socket with metal shut-off shutter, with airstream-operated triggering device, with fire protection housing, second room connection on left
ER - UPB/U	0093.0971	Metal exhaust socket with metal shut-off shutter, with airstream-operated triggering device, with fire protection housing, second room connection at bottom

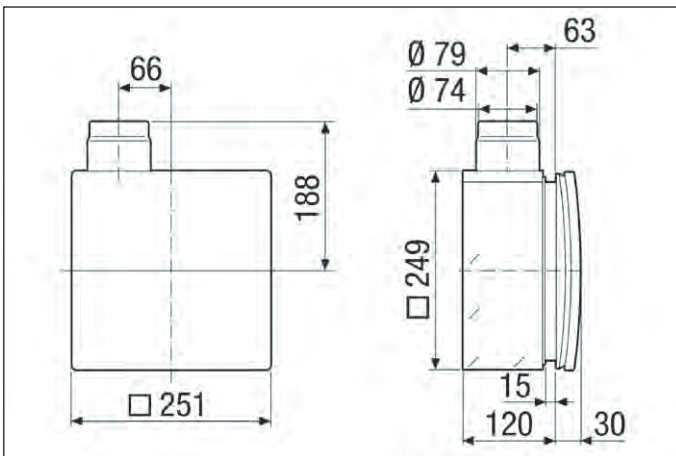
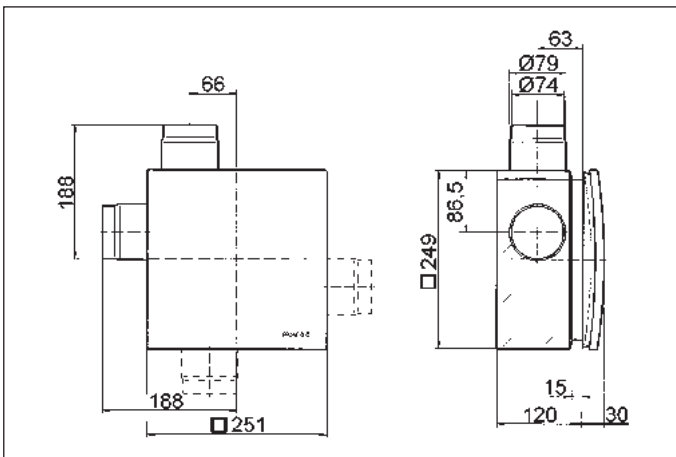
ER single air extraction system resp. Centro centralised ventilation system / ER-UPB recessed-mounted housing
Dimensions [mm]

Dimensions [mm]

ER-UPB with second room connection

Important accessories
Fan inserts

P. 66

Fan insert ER 60./ ER 100.. for ER-UP .. recessed-mounted housing

 ER 60 0084.0100
 ER 100 0084.0130

For other models, see page 68.

Spacing frame

P. 64

Spacing frame for ER-UP..recessed-mounted housings that have been plastered too deep

DR 60/100 0059.0928

Mounting support

P. 64

Mounting support for ER GH and ER-UP.. recessed-mounted housing

UPM 60/100 0018.0010

Masking frame

P. 64

Masking frame for ER-UP.. recessed-mounted housing with excess joint gap

ER-AR 0059.0899

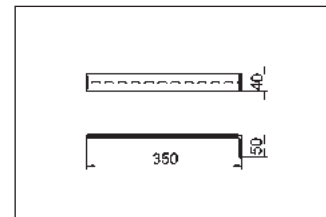
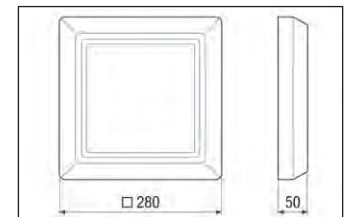
Dimensions [mm]

Dimensions [mm]

Wall frame

P. 64

Wall frames for housings that have been plastered too deep, to prevent the air from being drawn out of the shaft, sheet steel

ER-MR 0018.0024

Accessories for recessed-mounted housings for ER single air extraction system resp. Centro centralised ventilation system



Mounting support UPM 60/100

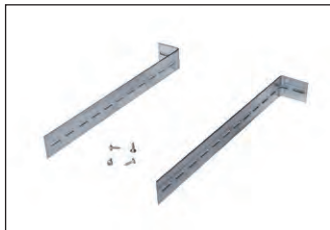

- Mounting support for installation of ER-GH and ER-UP.. recessed-mounted housing on walls, ceilings or in shafts.
- With slots for precise adjustment of the fan housing.
- Packing unit:
 - 2 L-shaped angle plates
 - 4 mounting screws.

Dimensions [mm]

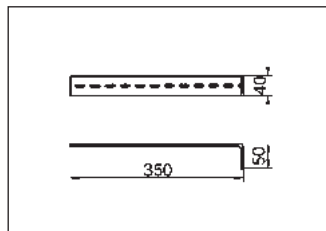

Features

Material	Sheet steel
----------	-------------

Article	Art. No.
UPM 60/100	0018.0010

Masking frame ER-AR



- Masking frame for all ER-UP... housings.
- Covers joints between the recessed housing and the wall tiles.
- Prevents unattractive gaps around the recessed housing.
- Scope of delivery:
 - Masking frame
 - Fixing screw.

Dimensions [mm]

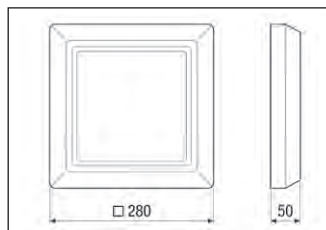

Features

Material	Synthetic material
Colour	Traffic white, similar to RAL 9016

Article	Art. No.
ER-AR	0059.0899

Spacing frame DR 60/100



- Spacing frame for ER-UP.. recessed-mounted housings that have not been plastered deep enough.
- Maximum depth: 20 mm.
- Fit a spacing frame between the wall and the internal cover.

Features

Material	Synthetic material
Colour	Traffic white, similar to RAL 9016
Width	253 mm
Height	253 mm
Depth	30 mm

Article	Art. No.
DR 60/100	0059.0928

Wall frame ER-MR



- Wall frames for housings that have been plastered too deep, to prevent the air from being drawn out of the shaft.
- Can be combined with all ER-UP... housings.
- Consists of 2 plate frames that can be slid inside each other.
- Adjustable depth: 60 mm to 90 mm.
- With 100 mm long screw.

Features

Material	Sheet steel
Width	230 mm
Height	230 mm
Depth	60 mm

Article	Art. No.
ER-MR	0018.0024

Accessories for recessed-mounted housings for ER single air extraction system resp. Centro centralised ventilation system

Second room extraction system ER-ZR



Article Art. No.
ER-ZR 0093.1025

- Second room connection kit with mounting couplings, internal grille and filter.
- In accordance with DIN 18017-3, can be combined with the following types: ER 100, ER 100 VZ, ER 100 VZ 15, ER 100 VZC, ER 100 G, ER 100 I or ER 100 D.
- Accessories: ZRF.. spare air filter.

Dimensions [mm]

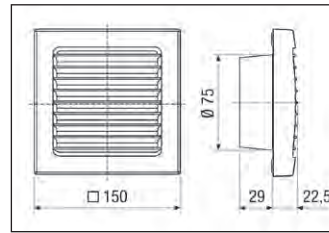

Features

Filter class	G2
Material	Synthetic material
Colour	Traffic white, similar to RAL 9016
Installation site	Wall
Max. ambient temperature	60 °C
Air direction	Air extraction

Air filter, replacement ZRF

Article Art. No.
ZRF 0093.0923

- Replacement filter for ER-ZR second room connection kit and for AZE 100 and ESG 10/2 internal grilles.

Features

Nominal size	100 mm
Filter class	G2
Width	125 mm
Height	125 mm
Depth	10 mm
Packing unit	5 pieces

Air extraction socket ER-AS



Article Art. No.
ER-AS 0093.0928

- Extraction socket for ER GH, ER-UPD and ER-UP/G recessed-mounted housing for toilet seat air extraction. Air extraction of room and WC seat at the same time.
- Pre-requirements: The flushing pipe from the recessed-mounted toilet cistern is fitted with a DN 70 branch.
- Connection from flushing pipe to the fan HT DN 70, resulting in reduced air speeds and effective, draught-free extraction.
- Combination with ER EC, ER 60 or ER 100.
- Cistern recommendation: Manufacturer TECE, TECEprofil Universal module for WC with TECE cistern with connection for odour extraction. TECE Order no.: 9.300.003, www.tece.de, Tel.: +49 (0) 25 72 / 928-0

Dimensions [mm]

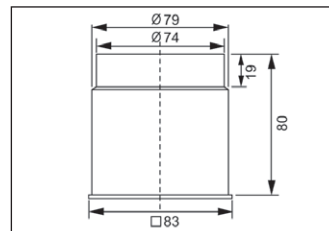

Features

Material	Synthetic material
Colour	Black
Installation site	Wall
Max. ambient temperature	60 °C
Air direction	Air extraction

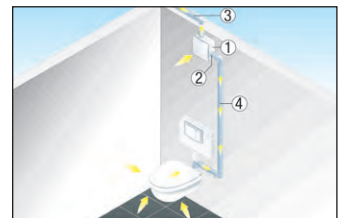

- Recessed-mounted housing ER-UP/G with Centro M
- ER-AS extraction socket
- Connection to exhaust air duct network:
 - with AFR 80 aluminium flexible duct for duct network made of folded spiral-seams duct or
 - with MF-F90 flexible duct without transition piece or
 - with 90° MF-B75 steel elbow or MF-FSM75 connector on MF-F75 flexible duct
- DN 70 HT duct

Sponge rubber set ER-MO



Article Art. No.
ER-MO 0092.0361

- Sponge rubber set for the sound insulation of ER GH, ER-UP/G and ER-UPD recessed housings, when used with highly resonant thin ceilings or walls.
- Length is enough for 2 housings.**

Features

Material	Synthetic material
Length	2.2 m

ER single air extraction system / ER 60 / ER 100 fan insert



- For single or second room air extraction using a single fan (exception: model H and GVZC EC).
- Electrical plug connection for quick fan installation in the housing.
- Trouble-free filter change without using tools.
- It is possible to rotate the cover by $\pm 5^\circ$, to compensate for housings which have been fitted at an angle.
- The housing has easy to install snap-in fan fittings.
- Colour: traffic white, similar to RAL 9016.
- All MAICO ER units have an IP X5 degree of protection and can be installed in area 1 in accordance with DIN VDE 0100-701, even with water jets. For details see planning instructions.
- Protection class II.
- The extremely steep characteristic curve shows the high pressure capacity of the ER fans.
- Robust energy saving capacitor motor.
- ER 60 GVZC EC: with energy-saving EC motor.
- Motor with thermal overload protection.
- Maintenance-free, with enclosed ball bearings on both sides.
- Volumetric flow characteristic curve and air leakage rate checked by TÜV Bayern e.V (German Technical Inspection Agency). Air leakage rate $< 0.01 \text{ m}^3/\text{h}$.
- Shaft level difference according to DIN 4109, tested by IAB Oberursel (The Institute for Acoustics and Building Physics in Germany).
- With VDE symbol.

Models

- For more details of models, see page 68.

Features

- Fan with cover and G2 filter for installation in recessed housings.

Technical data

Article	Art. No.	Model	U _{nom}	f _{nom}	Rotating speed	Air flow volume	Power consumption	I _{max}	T _{max at I_{max}}	Sound pressure level	Sound power level L _{WA7}	Filter class	Degree of protection IP	Mains cable mm ²
			V	Hz	1/min	m ³ /h	W	A	°C	dB(A)	dB(A)			
ER 60	0084.0100	Standard model	230	50	1,250	62	21	0.16	40	36 ¹⁾	40	G2	X5	3 x 1.5
ER 60 VZ	0084.0101	Time delay switch	230	50	1,250	62	21	0.16	40	36 ¹⁾	40	G2	X5	5 x 1.5
ER 60 VZ 15	0084.0108	Time delay switch, 15 minute overrun time	230	50	1,250	62	21	0.16	40	36 ¹⁾	40	G2	X5	5 x 1.5
ER 60 VZC	0084.0106	Adjustable time delay switch	230	50	1,250	62	21	0.16	40	36 ¹⁾	40	G2	X5	5 x 1.5
ER 60 F	0084.0102	Light control	230	50	1,250	62	21	0.16	40	36 ¹⁾	40	G2	X5	3 x 1.5
ER 60 G	0084.0103	Base load circuit	230	50	850/1,250	35/62	10/21	0.12/0.16	40	26/36 ¹⁾	30/40	G2	X5	5 x 1.5
ER 60 GVZ	0084.0107	Base load and delay time circuit	230	50	850/1,250	35/62	10/21	0.12/0.16	40	26/36 ¹⁾	30/40	G2	X5	5 x 1.5
ER 60 GVZC EC	0084.0116	EC model with base load and time delay switching.	230	50	850/1,250	35/62	3.9/6	0.03/0.05	40	26/36 ¹⁾	30/40	G2	X5	5 x 1.5
ER 60 H	0084.0104	Humidity control	230	50	850/1,250	35/62	10/21	0.12/0.16	40	26/36 ¹⁾	30/40	G2	X5	5 x 1.5
ER 60 I	0084.0105	Interval control	230	50	1,250	62	21	0.16	40	36 ¹⁾	40	G2	X5	5 x 1.5
ER 100	0084.0130	Standard model	230	50	1,900	101	29	0.14	40	45 ¹⁾	49	G2	X5	3 x 1.5
ER 100 VZ	0084.0131	Time delay switch	230	50	1,900	101	29.5	0.14	40	45 ¹⁾	49	G2	X5	5 x 1.5
ER 100 VZ 15	0084.0140	Time delay switch, 15 minute overrun time	230	50	1,900	101	29.5	0.14	40	45 ¹⁾	49	G2	X5	5 x 1.5
ER 100 VZC	0084.0136	Adjustable time delay switch	230	50	1,900	101	29.5	0.14	40	45 ¹⁾	49	G2	X5	5 x 1.5
ER 100 F	0084.0132	Light control	230	50	1,900	101	29.5	0.14	40	45 ¹⁾	49	G2	X5	3 x 1.5
ER 100 G	0084.0133	Base load circuit	230	50	850/1,900	35/101	9/29	0.09/0.14	40	26/45 ¹⁾	30/49	G2	X5	5 x 1.5
ER 100 GVZ	0084.0139	Base load and delay time circuit	230	50	850/1,900	35/101	9/29.5	0.09/0.14	40	26/45 ¹⁾	30/49	G2	X5	5 x 1.5
ER 100 H	0084.0134	Humidity control	230	50	850/1,900	35/101	9/29.5	0.09/0.14	40	26/45 ¹⁾	30/49	G2	X5	5 x 1.5
ER 100 I	0084.0135	Interval control	230	50	1,900	101	29.5	0.14	40	45 ¹⁾	49	G2	X5	5 x 1.5
ER 100 D	0084.0137	Model with three-speed switch	230	50	850/1,250/1,900	35/60/100	10/21/29	0.1/0.12/0.14	40	27/36/45 ¹⁾	31/40/49	G2	X5	5 x 1.5
ER 100 RC	0084.0129	Radio receiver	230	50	850/1,250/1,900	35/60/100	10/21/29.5	0.1/0.12/0.14	40	27/36/45 ¹⁾	31/40/49	G2	X5	3 x 1.5

¹⁾ Specifications in accordance with DIN 18017-3 at an equivalent absorption area $A_e = 10 \text{ m}^2$

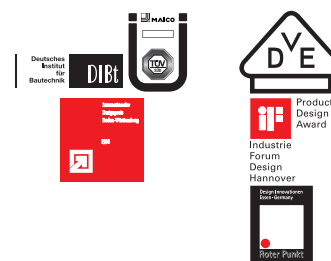

Dimensions [mm]

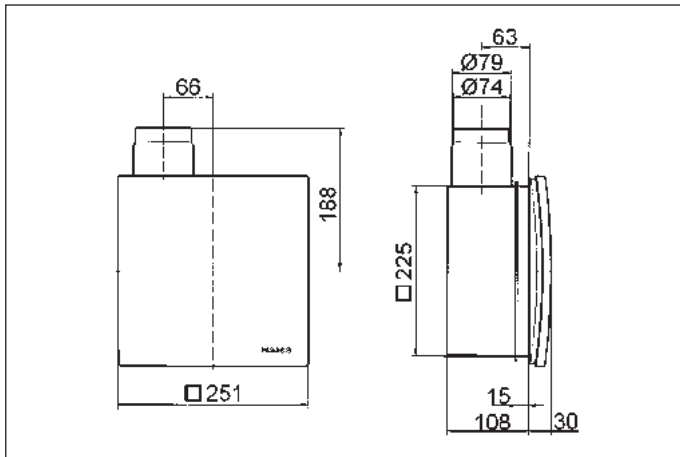

ER fan insert with recessed-mounted housing ER-UP/G or ER-UPD

Dimensions [mm]

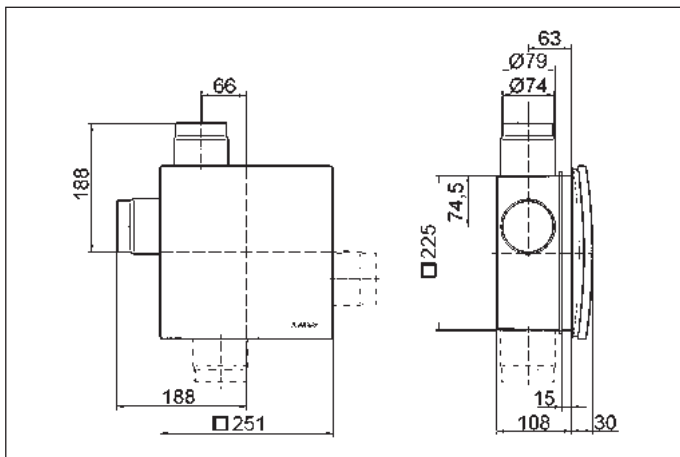

ER fan insert with recessed-mounted housing ER-UP/G or ER-UPD and second room connection

ER characteristic curves

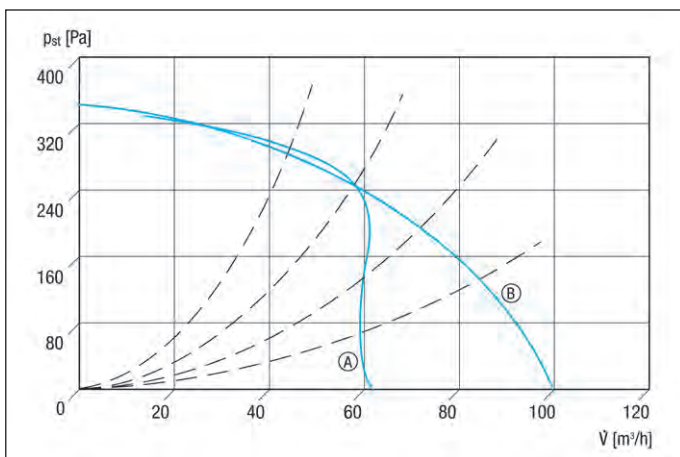

Ⓐ ER 60 ...
Ⓑ ER 100 ...

Important accessories

Recessed-mounted housing



P. 58

Recessed-mounted housing with plastic exhaust socket for fitting an ER 60 / ER 100 fan or Centro-M / Centro-E / Centro-H exhaust air element

ER - UP/G 0093.0995

Dimensions [mm]

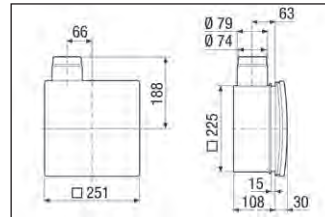

Recessed-mounted housing



P. 60

Recessed-mounted housing with fire protection shut-off device for fitting an ER 60 / ER 100 fan or Centro-M / Centro-E / Centro-H exhaust air element

ER - UPD 0093.0972

Dimensions [mm]

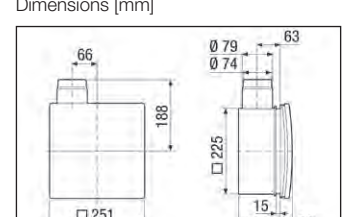

Recessed-mounted housings



P. 62

Recessed-mounted housing with fire-protection with fire-protection shut-off device for all fire protection systems for insertion of fan units ER 60 / ER 100 or exhaust air elements Centro-E / Centro-M / Centro H

ER - UPB 0093.0968

ER - UPB/R 0093.0969

ER - UPB/L 0093.0970

ER - UPB/U 0093.0971

Dimensions [mm]

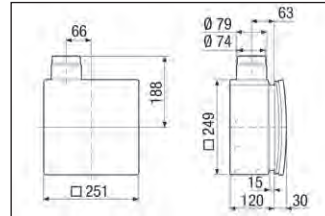

3-step switch



P. 77

3-level switch with zero position

DS 3N 0157.0186

Radio switch



P. 77

Radio switch for wireless switching ER 100 RC and ECA ... ipro RC/RCH fans

DS RC 0157.0832

Outside air openings



P. 309

Outside air openings for draught-free fresh air supply using outside air

ALD 125 0152.0067

ALD 125 VA 0152.0068

For other models, see page 308.

Dimensions [mm]

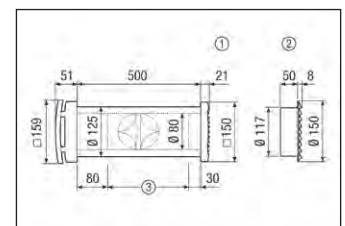

- ① Rectangular plastic external grille ALD 125
- ② Round stainless steel external grille ALD 125 VA
- ③ Shorten to wall thickness if required

Air filters, replacement

P. 77

Replacement air filter for ER, ER-AP/ APB or Centro, filter class G2

ZF 60/100 0093.0680

ZF 60/100 bulk container 0093.0885

Door ventilation grilles



P. 312

Door ventilation grille for bathroom, WC or kitchen

MLK 30 white 0151.0123

MLK 45 white 0151.0126

The following models are available:
Standard Standard model

- ER 100: Speed controllable.
- ER 60: Not speed controllable.

VZ Model with time delay switch

- Start delay approx. 50 sec.
- Overrun time approx. 6 min.
- Not speed-controllable.

VZ-15 Model with time delay switch with 15 minutes overrun time

- Start delay approx. 50 sec.
- Overrun time approx. 15 min.
- Not speed-controllable.

VZC Model with adjustable time delay switch

- Start delay can be set in steps from 0 to approx. 150 seconds.
- The overrun time can be adjusted from approx 1.5 min to 24 min.
- Not speed-controllable.

F Model with light control

- Barrier-free product as the fan switches itself on and off automatically.
- The light control switches on the fan when the minimum light intensity in the room is exceeded, e.g. when a light is switched on.
- Min. 30 lux switch-on intensity (on unit).
- Max. 0.3 lux switch-off intensity (on unit).
- No need to install a switch.
- Start delay approx. 50 sec.
- Overrun time approx. 6 min.
- Not speed-controllable.
- Switching variation: The fan can be switched off independently of the room lighting by an additional switch (see the wiring diagrams online).

B Model with base load circuit

- The unit runs in continuous operation at 35 m³/h.
- Can be switched over to full load, e. g. when normally unused rooms are used for a long period.
- Not speed controllable.
- Switching variation: The base load can be switched on or off by an additional switch (see the wiring diagrams online).

BVZ Model with base load circuit and time delay switch

- The unit runs in continuous operation at 35 m³/h.
- Switching to full load with start delay of approx. 50 sec.
- Full load overrun time approx. 6 min.
- Not speed-controllable.
- Switching variation: The base load can be switched on or off by an additional switch (see the wiring diagrams online).

BVZC EC Model with EC motor, base load circuit and time delay

- The unit runs in continuous operation at 35 m³/h.
- Switching to full load with adjustable start delay (0/0.5/1/2/3 minutes).
- Adjustable overrun time of the full load level (0/1/3/6/15 minutes).
- Not speed-controllable.
- Switching variation: The base load can be switched on or off by an additional switch (see the wiring diagrams online).

H Model with humidity control and base load circuit

- Barrier-free product as the fan switches itself on and off automatically.
- Switch-on point: 60 %, 70 %, 80 % or 90 % relative humidity can be set with jumper.
- Switch-off point: approx. 10 % below the switch-on point (always a fixed set value).
- Not speed-controllable.
- Not suitable for second room ventilation.
- Can be operated manually via a switch, e.g. switching full load on using a light switch.
- Standard switching: Fan runs in base load operation, humidity control is active, full load operation if the switch-on point is exceeded, base load operation if level falls below the switch-off point.
- Other switch variants: Fan mode with or without base load operation; manual engagement of full load; switching fan on or off using a switch.
- Activation of full load using light switch and a fan overrun control linked to this (6 minute overrun time).
- The fan always overruns until the air humidity in the room has fallen below the switch-off humidity level, regardless of the switch variants.

I Model with interval control.

- The interval control ventilates rooms that are not regularly used.
- Time interval adjustable from 1 to approx. 15 hrs.
- Approx. 10 min. operating time per interval.
- When operated manually (e.g. by light switch) there is a start delay of approx. 50 sec. and an overrun time of approx. 10 min.
- Interval control can be switched off.
- Not speed-controllable.

D Model with three-speed switch

- The air volume can be set in combination with a three-step switch:
 - Step 1: 35 m³/h
 - Step 2: 60 m³/h
 - Step 3: 100 m³/h
- Can be used when combined with supply air elements for controlled domestic ventilation.
- Use is particularly recommended when reconstruction measures are taken.
- Not speed-controllable.

RC Model with radio receiver

- On/off via DS RC radio switch or separate RLS RC control.
- Overrun time of around 15 min only when switching off in single mode with radio switch and deactivated DIN 18017-3 mode.
- The three speeds can be selected either on the radio switch or control.
- Not speed-controllable.
- Can be combined with Wibusler smart home system.

Accessories selection table

	ER 60	ER 60 VZ	ER 60 VZ 15	ER 60 VZC	ER 60 F	see
Recessed-mounted housing	ER - UP/G ER - UPD ER - UPB ER - UPB/R ER - UPB/L ER - UPB/U	ER - UP/G ER - UPD ER - UPB ER - UPB/R ER - UPB/L ER - UPB/U	ER - UP/G ER - UPD ER - UPB ER - UPB/R ER - UPB/L ER - UPB/U	ER - UP/G ER - UPD ER - UPB ER - UPB/R ER - UPB/L ER - UPB/U	ER - UP/G ER - UPD ER - UPB ER - UPB/R ER - UPB/L ER - UPB/U	P. 58
Air filter, replacement	ZF 60/100 ZF 60/100 bulk container	ZF 60/100 ZF 60/100 bulk container	ZF 60/100 ZF 60/100 bulk container	ZF 60/100 ZF 60/100 bulk container	ZF 60/100 ZF 60/100 bulk container	P. 77
Masking frame	ER-AR	ER-AR	ER-AR	ER-AR	ER-AR	P. 64
Spacing frame	DR 60/100	DR 60/100	DR 60/100	DR 60/100	DR 60/100	P. 64
Outside air opening	ALD 10 ALD 125 ALD 125 VA ALD 160 ALD 160 VA	ALD 10 ALD 125 ALD 125 VA ALD 160 ALD 160 VA	ALD 10 ALD 125 ALD 125 VA ALD 160 ALD 160 VA	ALD 10 ALD 125 ALD 125 VA ALD 160 ALD 160 VA	ALD 10 ALD 125 ALD 125 VA ALD 160 ALD 160 VA	P. 308
Roof outlet	DF	DF	DF	DF	DF	P. 306
Roofing tile	DP	DP	DP	DP	DP	P. 306
Mounting clamp	BS	BS	BS	BS	BS	P. 306
Rain protection grille	RG	RG	RG	RG	RG	P. 306
Door ventilation grille	MLK 30 white MLK 45 white	MLK 30 white MLK 45 white	MLK 30 white MLK 45 white	MLK 30 white MLK 45 white	MLK 30 white MLK 45 white	P. 312
Flexible aluminium duct	AFR	AFR	AFR	AFR	AFR	P. 319
Radio switch	XS 1	XS 1	XS 1	XS 1	XS 1	P. 350
Radio receiver	XE 1	XE 1	XE 1	XE 1	XE 1	P. 350
Time delay switch	VZ 6 VZ 12 VZ 24 C	–	–	–	–	P. 342
Interval switch	VZI 10	–	–	–	–	P. 342
Hygrostat	HY 230 HY 230 I	HY 230 HY 230 I	HY 230 HY 230 I	HY 230 HY 230 I	–	P. 348

	ER 60 G	ER 60 GVZ	ER 60 GVZC EC	ER 60 H	ER 60 I	see
Recessed-mounted housing	ER - UP/G ER - UPD ER - UPB ER - UPB/R ER - UPB/L ER - UPB/U	ER - UP/G ER - UPD ER - UPB ER - UPB/R ER - UPB/L ER - UPB/U	ER - UP/G ER - UPD ER - UPB ER - UPB/R ER - UPB/L ER - UPB/U	ER - UP/G ER - UPD ER - UPB	ER - UP/G ER - UPD ER - UPB ER - UPB/R ER - UPB/L ER - UPB/U	P. 58
Air filter, replacement	ZF 60/100 ZF 60/100 bulk container	ZF 60/100 ZF 60/100 bulk container	ZF 60/100 ZF 60/100 bulk container	ZF 60/100 ZF 60/100 bulk container	ZF 60/100 ZF 60/100 bulk container	P. 77
Masking frame	ER-AR	ER-AR	ER-AR	ER-AR	ER-AR	P. 64
Spacing frame	DR 60/100	DR 60/100	DR 60/100	DR 60/100	DR 60/100	P. 64
Outside air opening	ALD 10 ALD 125 ALD 125 VA ALD 160 ALD 160 VA	ALD 10 ALD 125 ALD 125 VA ALD 160 ALD 160 VA	ALD 10 ALD 125 ALD 125 VA ALD 160 ALD 160 VA	ALD 10 ALD 125 ALD 125 VA ALD 160 ALD 160 VA	ALD 10 ALD 125 ALD 125 VA ALD 160 ALD 160 VA	P. 308
Roof outlet	DF	DF	DF	DF	DF	P. 306
Roofing tile	DP	DP	DP	DP	DP	P. 306
Mounting clamp	BS	BS	BS	BS	BS	P. 306
Rain protection grille	RG	RG	RG	RG	RG	P. 306
Door ventilation grille	MLK 30 white MLK 45 white	MLK 30 white MLK 45 white	MLK 30 white MLK 45 white	MLK 30 white MLK 45 white	MLK 30 white MLK 45 white	P. 312
Flexible aluminium duct	AFR	AFR	AFR	AFR	AFR	P. 319
Radio switch	XS 1	XS 1	XS 1	XS 1	XS 1	P. 350
Radio receiver	XE 1	XE 1	XE 1	XE 1	XE 1	P. 350
Timer	ZS 4	–	ZS 4	–	–	P. 343
Hygrostat	HY 230 HY 230 I	HY 230 HY 230 I	HY 230 HY 230 I	–	HY 230 HY 230 I	P. 348

ER single air extraction system / ER 60 / ER 100 fan insert

Accessories selection table

	ER 100	ER 100 VZ	ER 100 VZ 15	ER 100 VZC	ER 100 F	see	
Recessed-mounted housing	ER - UP/G ER - UPD ER - UPB ER - UPB/R ER - UPB/L ER - UPB/U	ER - UP/G ER - UPD ER - UPB ER - UPB/R ER - UPB/L ER - UPB/U	ER - UP/G ER - UPD ER - UPB ER - UPB/R ER - UPB/L ER - UPB/U	ER - UP/G ER - UPD ER - UPB ER - UPB/R ER - UPB/L ER - UPB/U	ER - UP/G ER - UPD ER - UPB ER - UPB/R ER - UPB/L ER - UPB/U	ER - UP/G ER - UPD ER - UPB ER - UPB/R ER - UPB/L ER - UPB/U	P. 58
Air filter, replacement	ZF 60/100 ZF 60/100 bulk container	ZF 60/100 ZF 60/100 bulk container	ZF 60/100 ZF 60/100 bulk container	ZF 60/100 ZF 60/100 bulk container	ZF 60/100 ZF 60/100 bulk container	P. 77	
Masking frame	ER-AR	ER-AR	ER-AR	ER-AR	ER-AR	P. 64	
Spacing frame	DR 60/100	DR 60/100	DR 60/100	DR 60/100	DR 60/100	P. 64	
Second room extraction system	ER-ZR	ER-ZR	ER-ZR	ER-ZR	-	P. 65	
Outside air opening	ALD 10 ALD 125 ALD 125 VA ALD 160 ALD 160 VA	ALD 10 ALD 125 ALD 125 VA ALD 160 ALD 160 VA	ALD 10 ALD 125 ALD 125 VA ALD 160 ALD 160 VA	ALD 10 ALD 125 ALD 125 VA ALD 160 ALD 160 VA	ALD 10 ALD 125 ALD 125 VA ALD 160 ALD 160 VA	P. 308	
Roof outlet	DF	DF	DF	DF	DF	P. 306	
Roofing tile	DP	DP	DP	DP	DP	P. 306	
Mounting clamp	BS	BS	BS	BS	BS	P. 306	
Rain protection grille	RG	RG	RG	RG	RG	P. 306	
Door ventilation grille	MLK 30 white MLK 45 white	MLK 30 white MLK 45 white	MLK 30 white MLK 45 white	MLK 30 white MLK 45 white	MLK 30 white MLK 45 white	P. 312	
Flexible aluminium duct	AFR	AFR	AFR	AFR	AFR	P. 319	
Step switch	FS 4	-	-	-	-	P. 335	
Radio switch	XS 1	XS 1	XS 1	XS 1	XS 1	P. 350	
Radio receiver	XE 1	XE 1	XE 1	XE 1	XE 1	P. 350	
Speed controller	ST 1 STU 1	-	-	-	-	P. 338	
Speed controller, distribution board	STS 2,5	-	-	-	-	P. 339	
Interval switch	VZI 10	-	-	-	-	P. 342	
Hygrostat	HY 230 HY 230 I	HY 230 HY 230 I	HY 230 HY 230 I	HY 230 HY 230 I	-	P. 348	
	ER 100 G	ER 100 GVZ	ER 100 H	ER 100 I	ER 100 D	ER 100 RC	see
Recessed-mounted housing	ER - UP/G ER - UPD ER - UPB ER - UPB/R ER - UPB/L ER - UPB/U	ER - UP/G ER - UPD ER - UPB ER - UPB/R ER - UPB/L ER - UPB/U	ER - UP/G ER - UPD ER - UPB	ER - UP/G ER - UPD ER - UPB ER - UPB/R ER - UPB/L ER - UPB/U	ER - UP/G ER - UPD ER - UPB ER - UPB/R ER - UPB/L ER - UPB/U	ER - UP/G ER - UPD ER - UPB ER - UPB/R ER - UPB/L ER - UPB/U	P. 58
Air filter, replacement	ZF 60/100 ZF 60/100 bulk container	ZF 60/100 ZF 60/100 bulk container	ZF 60/100 ZF 60/100 bulk container	ZF 60/100 ZF 60/100 bulk container	ZF 60/100 ZF 60/100 bulk container	ZF 60/100 ZF 60/100 bulk container	P. 77
Masking frame	ER-AR	ER-AR	ER-AR	ER-AR	ER-AR	ER-AR	P. 64
Spacing frame	DR 60/100	DR 60/100	DR 60/100	DR 60/100	DR 60/100	DR 60/100	P. 64
Second room extraction system	ER-ZR	ER-ZR	-	ER-ZR	ER-ZR	ER-ZR	P. 65
Room air control	-	-	-	-	-	RLS RC	P. 98
Radio switch	-	-	-	-	-	DS RC	P. 77
3-step switch	-	-	-	-	DS 3N	-	P. 77
Outside air opening	ALD 10 ALD 125 ALD 125 VA ALD 160 ALD 160 VA	ALD 10 ALD 125 ALD 125 VA ALD 160 ALD 160 VA	ALD 10 ALD 125 ALD 125 VA ALD 160 ALD 160 VA	ALD 10 ALD 125 ALD 125 VA ALD 160 ALD 160 VA	ALD 10 ALD 125 ALD 125 VA ALD 160 ALD 160 VA	ALD 10 ALD 125 ALD 125 VA ALD 160 ALD 160 VA	P. 308
Roof outlet	DF	DF	DF	DF	DF	DF	P. 306
Roofing tile	DP	DP	DP	DP	DP	DP	P. 306
Mounting clamp	BS	BS	BS	BS	BS	BS	P. 306
Rain protection grille	RG	RG	RG	RG	RG	RG	P. 306
Door ventilation grille	MLK 30 white MLK 45 white	MLK 30 white MLK 45 white	MLK 30 white MLK 45 white	MLK 30 white MLK 45 white	MLK 30 white MLK 45 white	MLK 30 white MLK 45 white	P. 312
Flexible aluminium duct	AFR	AFR	AFR	AFR	AFR	AFR	P. 319
Radio switch	XS 1	XS 1	XS 1	XS 1	-	-	P. 350
Radio receiver	XE 1	XE 1	XE 1	XE 1	-	-	P. 350
Room air control	-	-	-	-	RLS 3	-	P. 77
Timer	ZS 4	-	-	-	-	-	P. 343
Hygrostat	HY 230 HY 230 I	HY 230 HY 230 I	-	HY 230 HY 230 I	HY 230 HY 230 I	-	P. 348



- **Housing can be turned, so the exhaust socket can be connected to main duct in the top left or top right.**
- Colour: traffic white, similar to RAL 9016.
- DN 75/80 plastic exhaust socket with airstream-operated synthetic backflow preventer.
- The extremely steep characteristic curve shows the high pressure capacity of the ER fans.
- All MAICO ER units have an IP X5 degree of protection and can be installed in area 1 in accordance with DIN VDE 0100-701, even with water jets. For details, please refer to the planning instructions.
- Protection class II.
- Robust energy saving capacitor motor.
- Maintenance-free, with enclosed ball bearings on both sides.
- Electrical plug connection for quick fan installation in the housing.
- General official approval, approval no.: Z-51.1-42.
- Certificates of approval on request or on our website - www.maico-fans.com.
- Volumetric flow characteristic curve and air leakage rate checked by TÜV Bayern e.V (German Technical Inspection Agency). Air leakage rate < 0.01 m³/h.
- Shaft level difference according to DIN 4109, tested by IAB Oberursel (The Institute for Acoustics and Building Physics in Germany).
- With VDE symbol.

Models

- For more details of models, see page 68.

Features

- Surface-mounted fan with G2 filter for air extraction in domestic kitchens, bathrooms or WCs.
- Trouble-free filter exchange without using tools.

Exhaust air system	Installable	Note
aeroduct fire protection system	No	-
PAM-GLOBAL L cast iron ventilation system	No	-
Ceiling barrier system	Yes	within and outside the shaft, connecting duct with flexible aluminium duct, second room connection with flexible aluminium duct
System with fire-proof shaft	No	-
Air extraction system without fire protection	Yes	within and outside the shaft, connecting duct with flexible aluminium duct, second room connection with flexible aluminium duct

Technical data

Article	Art. No.	Model	U _{nom}	Rotating speed	Air flow volume	Power consumption	I _{max}	T _{max} at I _{max}	Sound pressure level	Sound power level L _{WA7}	Filter class	Degree of protection	Mains cable
			V	1/min	m³/h	W	A	°C	dB(A)	dB(A)			
ER-AP 60	0084.0150	Standard model	230	1,250	61	21	0.17	40	40 ¹⁾	43	G2	X5	3 x 1.5
ER-AP 60 VZ	0084.0151	Time delay switch	230	1,250	61	21	0.17	40	40 ¹⁾	43	G2	X5	5 x 1.5
ER-AP 60 F	0084.0152	Light control	230	1,250	61	21	0.17	40	40 ¹⁾	43	G2	X5	3 x 1.5
ER-AP 60 G	0084.0153	Base load circuit	230	900/1,250	35/61	11/21	0.13/0.17	40	33/40 ¹⁾	37/43	G2	X5	5 x 1.5
ER-AP 60 H	0084.0154	Humidity control	230	900/1,250	35/61	11/21	0.13/0.17	40	33/40 ¹⁾	37/43	G2	X5	5 x 1.5
ER-AP 100	0084.0170	Standard model	230	1,850	100	28.5	0.15	40	49 ¹⁾	53	G2	X5	3 x 1.5
ER-AP 100 VZ	0084.0171	Time delay switch	230	1,850	100	29	0.15	40	49 ¹⁾	53	G2	X5	5 x 1.5
ER-AP 100 F	0084.0172	Light control	230	1,850	100	29	0.15	40	49 ¹⁾	53	G2	X5	3 x 1.5
ER-AP 100 G	0084.0173	Base load circuit	230	900/1,850	35/100	10/28.5	0.09/0.15	40	33/49 ¹⁾	37/53	G2	X5	5 x 1.5
ER-AP 100 H	0084.0174	Humidity control	230	900/1,850	35/100	10/29	0.09/0.15	40	33/49 ¹⁾	37/53	G2	X5	5 x 1.5

¹⁾ Specifications in accordance with DIN 18017-3 at an equivalent absorption area A_L = 10 m.²



Dimensions [mm]

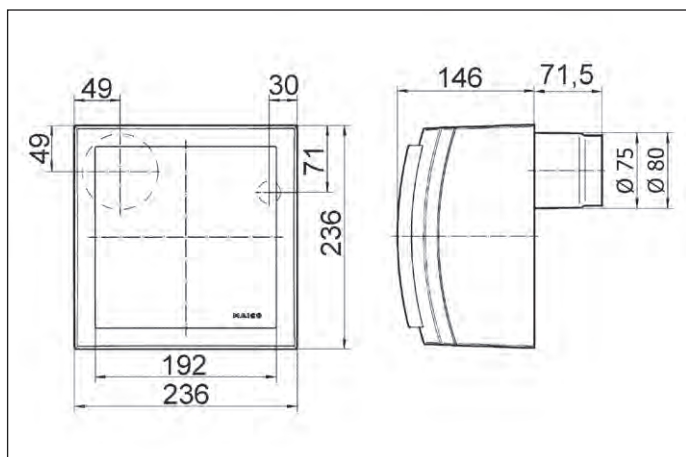

Characteristic curve ER-AP characteristic curves

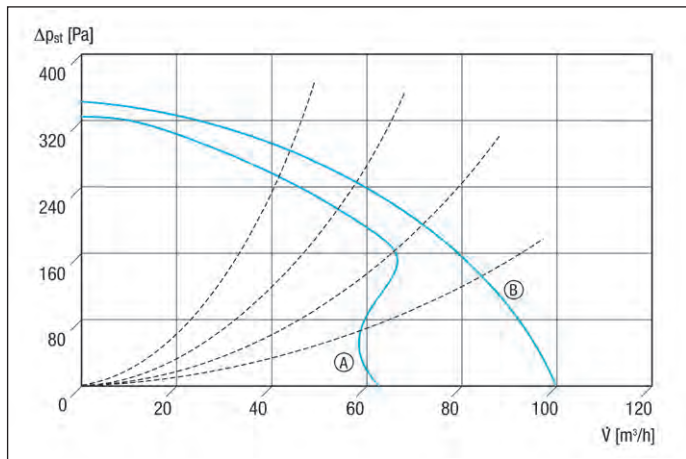

Ⓐ ER-AP 60 ...
 Ⓑ ER-AP 100 ...

Important accessories

Air filters, replacement

P. 77

Replacement air filter for ER, ER-AP/ APB or Centro, filter class G2

ZF 60/100 0093.0680
 ZF 60/100 bulk container 0093.0885

Door ventilation grilles



P. 312

Door ventilation grille for bathroom, WC or kitchen

MLK 30 white 0151.0123
 MLK 45 white 0151.0126

Outside air openings



P. 309

Outside air openings for draught-free fresh air supply using outside air

ALD 125 0152.0067
 ALD 125 VA 0152.0068

For more models, see page 308.

Dimensions [mm]

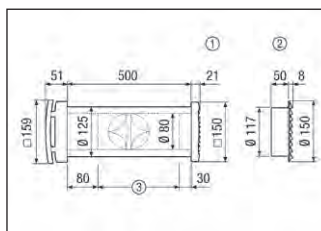

- ① Rectangular plastic external grille ALD 125
- ② Round stainless steel external grille ALD 125 VA
- ③ Shorten to wall thickness if required

Accessories selection table

	ER-AP 60	ER-AP 60 VZ	ER-AP 60 F	ER-AP 60 G	ER-AP 60 H	see
Air filter, replacement	ZF 60/100 ZF 60/100 bulk container	ZF 60/100 ZF 60/100 bulk container	ZF 60/100 ZF 60/100 bulk container	ZF 60/100 ZF 60/100 bulk container	ZF 60/100 ZF 60/100 bulk container	P. 77
Outside air opening	ALD 10 ALD 125 ALD 125 VA ALD 160 ALD 160 VA	ALD 10 ALD 125 ALD 125 VA ALD 160 ALD 160 VA	ALD 10 ALD 125 ALD 125 VA ALD 160 ALD 160 VA	ALD 10 ALD 125 ALD 125 VA ALD 160 ALD 160 VA	ALD 10 ALD 125 ALD 125 VA ALD 160 ALD 160 VA	P. 308
Roof outlet	DF	DF	DF	DF	DF	P. 306
Roofing tile	DP	DP	DP	DP	DP	P. 306
Mounting clamp	BS	BS	BS	BS	BS	P. 306
Rain protection grille	RG	RG	RG	RG	RG	P. 306
Door ventilation grille	MLK 30 white MLK 45 white	MLK 30 white MLK 45 white	MLK 30 white MLK 45 white	MLK 30 white MLK 45 white	MLK 30 white MLK 45 white	P. 312
Flexible aluminium duct	AFR	AFR	AFR	AFR	AFR	P. 319
Radio switch	XS 1	XS 1	XS 1	XS 1	XS 1	P. 350
Radio receiver	XE 1	XE 1	XE 1	XE 1	XE 1	P. 350
Time delay switch	VZ 6 VZ 12 VZ 24 C	–	–	–	–	P. 342
Interval switch	VZI 10	–	–	–	–	P. 342
Timer	–	–	–	ZS 4	–	P. 343
Hygrostat	HY 230 HY 230 I	HY 230 HY 230 I	–	HY 230 HY 230 I	–	P. 348

	ER-AP 100	ER-AP 100 VZ	ER-AP 100 F	ER-AP 100 G	ER-AP 100 H	see
Air filter, replacement	ZF 60/100 ZF 60/100 bulk container	ZF 60/100 ZF 60/100 bulk container	ZF 60/100 ZF 60/100 bulk container	ZF 60/100 ZF 60/100 bulk container	ZF 60/100 ZF 60/100 bulk container	P. 77
Outside air opening	ALD 10 ALD 125 ALD 125 VA ALD 160 ALD 160 VA	ALD 10 ALD 125 ALD 125 VA ALD 160 ALD 160 VA	ALD 10 ALD 125 ALD 125 VA ALD 160 ALD 160 VA	ALD 10 ALD 125 ALD 125 VA ALD 160 ALD 160 VA	ALD 10 ALD 125 ALD 125 VA ALD 160 ALD 160 VA	P. 308
Roof outlet	DF	DF	DF	DF	DF	P. 306
Roofing tile	DP	DP	DP	DP	DP	P. 306
Mounting clamp	BS	BS	BS	BS	BS	P. 306
Rain protection grille	RG	RG	RG	RG	RG	P. 306
Door ventilation grille	MLK 30 white MLK 45 white	MLK 30 white MLK 45 white	MLK 30 white MLK 45 white	MLK 30 white MLK 45 white	MLK 30 white MLK 45 white	P. 312
Flexible aluminium duct	AFR	AFR	AFR	AFR	AFR	P. 319
Step switch	FS 4	–	–	–	–	P. 335
Radio switch	XS 1	XS 1	XS 1	XS 1	XS 1	P. 350
Radio receiver	XE 1	XE 1	XE 1	XE 1	XE 1	P. 350
Speed controller	ST 1 STU 1	–	–	–	–	P. 338
Speed controller, distribution board	STS 2,5	–	–	–	–	P. 339
Time delay switch	VZ 6 VZ 12 VZ 24 C	–	–	–	–	P. 342
Interval switch	VZI 10	–	–	–	–	P. 342
Timer	–	–	–	ZS 4	–	P. 343
Hygrostat	HY 230 HY 230 I	HY 230 HY 230 I	–	HY 230 HY 230 I	–	P. 348

ER single air extraction system / ER-APB surface-mounted fan, fire protection



- With K90-18017 maintenance-free metal fire protection shut-off device against spread of fire.
- **Housing can be turned, so the exhaust socket can be connected to main duct in the top left or top right.**
- Colour: traffic white, similar to RAL 9016.
- Trouble-free filter exchange without using tools.
- DN 75/80 metal exhaust socket with metal shut-off device with airstream-operated release mechanism.
- The extremely steep characteristic curve shows the high pressure capacity of the ER fans.
- Robust energy saving capacitor motor.
- Maintenance-free, with enclosed ball bearings on both sides.
- Electrical plug connection for quick fan installation in the housing.
- All MAICO ER units have an IP X5 degree of protection and can be installed in area 1 in accordance with DIN VDE 0100-701, even with water jets. For details, please refer to the planning instructions.
- Protection class II.
- General official approval, approval no.: Z-51.1-45.
- Certificates of approval on request or on our website - www.maico-fans.com.
- Volumetric flow characteristic curve and air leakage rate checked by TÜV Bayern e.V (German Technical Inspection Agency). Air leakage rate < 0.01 m³/h.
- Shaft level difference according to DIN 4109, tested by IAB Oberursel (The Institute for Acoustics and Building Physics in Germany).
- With VDE symbol.

Models

- For more details of models, see page 68.

Features

- Surface-mounted fan with G2 filter for air extraction in bathrooms, WCs or domestic kitchens.

Exhaust air system	installable	Note
aeroduct fire protection system	yes	on and outside the shaft, Connecting duct with flexible steel duct
PAM-GLOBAL RML cast ventilation system	yes	on and outside the shaft, Connecting duct with flexible steel duct
Ceiling barrier system	yes	not mandatory
System with fire-proof shaft	yes	on and outside the shaft, on the shaft: Connecting duct with flexible aluminium duct outside of the shaft: Connecting duct with flexible steel duct
Air extraction system without fire protection	yes	not mandatory

Technical data

Article	Art. No.	Model	U _{nom}	Rotating speed	Air flow volume	Power consumption	I _{max}	T _{max} at I _{max}	Sound pressure level	Sound power level L _{WA7}	Filter class	Degree of protection	Mains cable
			V	1/min	m³/h	W	A	°C	dB(A)	dB(A)			
ER-APB 60	0084.0156	Standard model	230	1,250	61	21	0.17	40	43 ¹⁾	46	G2	X5	3 x 1.5
ER-APB 60 VZ	0084.0157	Time delay switch	230	1,250	61	21	0.17	40	43 ¹⁾	46	G2	X5	5 x 1.5
ER-APB 60 F	0084.0158	Light control	230	1,250	61	21	0.17	40	43 ¹⁾	46	G2	X5	3 x 1.5
ER-APB 60 G	0084.0159	Base load circuit	230	900/1,250	35/61	11/21	0.13/0.17	40	33/43 ¹⁾	37/46	G2	X5	5 x 1.5
ER-APB 60 H	0084.0160	Humidity control	230	900/1,250	35/61	11/21	0.13/0.17	40	33/43 ¹⁾	37/46	G2	X5	5 x 1.5
ER-APB 100	0084.0176	Standard model	230	1,850	100	28.5	0.15	40	49 ¹⁾	53	G2	X5	3 x 1.5
ER-APB 100 VZ	0084.0177	Time delay switch	230	1,850	100	29	0.15	40	49 ¹⁾	53	G2	X5	5 x 1.5
ER-APB 100 F	0084.0178	Light control	230	1,850	100	29	0.15	40	49 ¹⁾	53	G2	X5	3 x 1.5
ER-APB 100 G	0084.0179	Base load circuit	230	900/1,850	35/100	10/28.5	0.09/0.15	40	33/49 ¹⁾	37/53	G2	X5	5 x 1.5
ER-APB 100 H	0084.0180	Humidity control	230	900/1,850	35/100	10/29	0.09/0.15	40	33/49 ¹⁾	37/53	G2	X5	5 x 1.5

¹⁾ Specifications in accordance with DIN 18017-3 at an equivalent absorption area A_e = 10 m.²



Dimensions [mm]

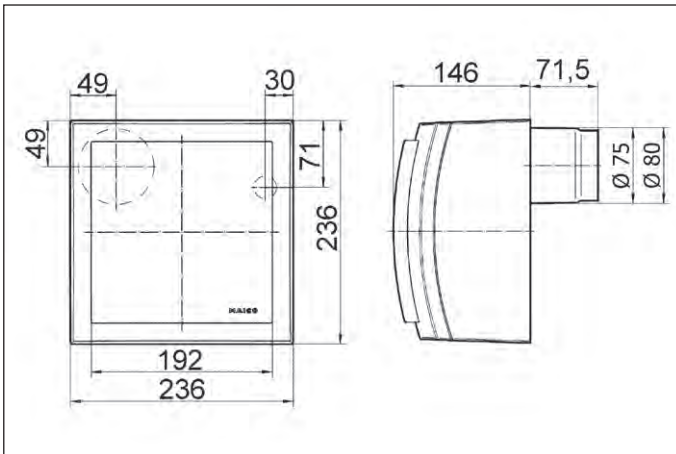

ER-APB characteristic curves

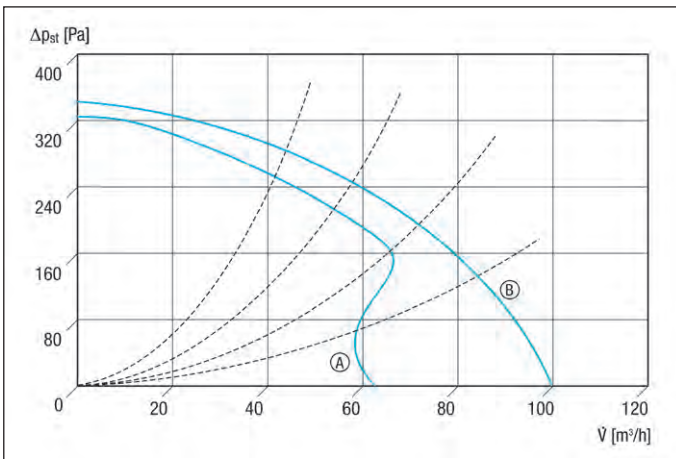

Ⓐ ER-APB 60 ...
 Ⓑ ER-APB 100 ...

Important accessories

Air filters, replacement

P. 77

Replacement air filter for ER, ER-AP/APB or Centro, filter class G2

ZF 60/100 0093.0680
 ZF 60/100 bulk container 0093.0885

Door ventilation grilles



P. 312

Door ventilation grille for bathroom, WC or kitchen

MLK 30 white 0151.0123
 MLK 45 white 0151.0126

Outside air openings



P. 309

Outside air openings for draught-free fresh air supply using outside air

ALD 125 0152.0067
 ALD 125 VA 0152.0068

For more models, see page 308.

Dimensions [mm]

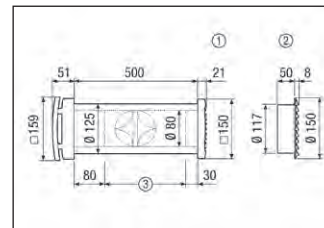

- ① Rectangular plastic external grille ALD 125
- ② Round stainless steel external grille ALD 125 VA
- ③ Shorten to wall thickness if required

Accessories selection table

	ER-APB 60	ER-APB 60 VZ	ER-APB 60 F	ER-APB 60 G	ER-APB 60 H	see
Air filter, replacement	ZF 60/100 ZF 60/100 bulk container	ZF 60/100 ZF 60/100 bulk container	ZF 60/100 ZF 60/100 bulk container	ZF 60/100 ZF 60/100 bulk container	ZF 60/100 ZF 60/100 bulk container	P. 77
Outside air opening	ALD 10 ALD 125 ALD 125 VA ALD 160 ALD 160 VA	ALD 10 ALD 125 ALD 125 VA ALD 160 ALD 160 VA	ALD 10 ALD 125 ALD 125 VA ALD 160 ALD 160 VA	ALD 10 ALD 125 ALD 125 VA ALD 160 ALD 160 VA	ALD 10 ALD 125 ALD 125 VA ALD 160 ALD 160 VA	P. 308
Roof outlet	DF	DF	DF	DF	DF	P. 306
Roofing tile	DP	DP	DP	DP	DP	P. 306
Mounting clamp	BS	BS	BS	BS	BS	P. 306
Rain protection grille	RG	RG	RG	RG	RG	P. 306
Door ventilation grille	MLK 30 white MLK 45 white	MLK 30 white MLK 45 white	MLK 30 white MLK 45 white	MLK 30 white MLK 45 white	MLK 30 white MLK 45 white	P. 312
Flexible aluminium duct	AFR	AFR	AFR	AFR	AFR	P. 319
Radio switch	XS 1	XS 1	XS 1	XS 1	XS 1	P. 350
Radio receiver	XE 1	XE 1	XE 1	XE 1	XE 1	P. 350
Time delay switch	VZ 6 VZ 12 VZ 24 C	-	-	-	-	P. 342
Interval switch	VZI 10	-	-	-	-	P. 342
Timer	-	-	-	ZS 4	-	P. 343
Hygrostat	HY 230 HY 230 I	HY 230 HY 230 I	-	HY 230 HY 230 I	-	P. 348

	ER-APB 100	ER-APB 100 VZ	ER-APB 100 F	ER-APB 100 G	ER-APB 100 H	see
Air filter, replacement	ZF 60/100 ZF 60/100 bulk container	ZF 60/100 ZF 60/100 bulk container	ZF 60/100 ZF 60/100 bulk container	ZF 60/100 ZF 60/100 bulk container	ZF 60/100 ZF 60/100 bulk container	P. 77
Outside air opening	ALD 10 ALD 125 ALD 125 VA ALD 160 ALD 160 VA	ALD 10 ALD 125 ALD 125 VA ALD 160 ALD 160 VA	ALD 10 ALD 125 ALD 125 VA ALD 160 ALD 160 VA	ALD 10 ALD 125 ALD 125 VA ALD 160 ALD 160 VA	ALD 10 ALD 125 ALD 125 VA ALD 160 ALD 160 VA	P. 308
Roof outlet	DF	DF	DF	DF	DF	P. 306
Roofing tile	DP	DP	DP	DP	DP	P. 306
Mounting clamp	BS	BS	BS	BS	BS	P. 306
Rain protection grille	RG	RG	RG	RG	RG	P. 306
Door ventilation grille	MLK 30 white MLK 45 white	MLK 30 white MLK 45 white	MLK 30 white MLK 45 white	MLK 30 white MLK 45 white	MLK 30 white MLK 45 white	P. 312
Flexible aluminium duct	AFR	AFR	AFR	AFR	AFR	P. 319
Step switch	FS 4	-	-	-	-	P. 335
Radio switch	XS 1	XS 1	XS 1	XS 1	XS 1	P. 350
Radio receiver	XE 1	XE 1	XE 1	XE 1	XE 1	P. 350
Speed controller	ST 1 STU 1	-	-	-	-	P. 338
Speed controller, distribution board	STS 2,5	-	-	-	-	P. 339
Interval switch	VZI 10	-	-	-	-	P. 342
Timer	-	-	-	ZS 4	-	P. 343
Hygrostat	HY 230 HY 230 I	HY 230 HY 230 I	-	HY 230 HY 230 I	-	P. 348

**Room air control
RLS 3**

Article	Art. No.
RLS 3	0157.0831

- Three-step room air control for ER 100 D exhaust air fan, ZEG 2000 P exhaust air unit, WS 150 centralised ventilation unit and HDR EC duct fan.
- 3 switching steps: Base load, Normal, Full-load (rotary knob).
- With separate, 2-pole on/off switch (rocker switch).
- Both switches in joint double frame.

Features

U _{nom}	230 V
Degree of protection	IP 30
Maximum load	10 A
Material	Synthetic material
Type of installation	Recessed-mounted
Width	150 mm
Height	80 mm
Depth	32 mm

**3-step switch
DS 3N**

Article	Art. No.
DS 3N	0157.0186

- Rotary switch for controlling 3-step ventilation units (e.g. ER 100 D exhaust air fan).
- Suitable for standard recessed-mounted boxes.
- With zero setting.

Features

U _{nom}	230 V
Degree of protection	IP 30
Maximum load	16 A
Colour	polar white, similar to RAL 9010, matt
Type of installation	Recessed-mounted
Width	80 mm
Height	80 mm
Depth	32 mm

**Radio switch
DS RC**

Article	Art. No.
DS RC	0157.0832



- EnOcean radio switch.
- The radio switch can be used individually with the ECA ... ipro RC/RCH, ER 100 RC fans or the MAICOsmart system.
- The radio switch can also be used in combination with the EnOcean plug-in module E-SM in order to control the WS 160 Flat, WS 170 KBR...WS 170 KBL..., WS 320/470 and WR 310/410 centralised ventilation units using EnOcean.
- For redevelopments and retrofit installations – no painting or wallpapering.
- Tiles don't need to be removed or renewed.
- Application wherever no control cable can be installed.
- Radio switch can be used on the move.
- Radio switch requires no batteries.
- Radio switch can be screwed on or attached to a glass surface.
- Simple transmitter teaching-in saves on time-consuming programming.

Features

Battery	not required
Degree of protection	IP 20
Material	Synthetic material
Colour	Pure white, similar to RAL 9010
Type of installation	Surface-mounted
Installation site	Wall
Mains cable	not required
Minimum ambient temperature	-25 °C
Max. ambient temperature	65 °C
Width	83 mm
Height	83 mm
Depth	16 mm
Transmission range in the building	30 m
Radio frequency	868.3 MHz

**Air filters, replacement
ZF**

Article	Art. No.	Packing unit
ZF 60/100	0093.0680	5 pieces
ZF 60/100 bulk container	0093.0885	100 pieces

- Replacement air filter for ER and ER-AP/ER-APB fan inserts and Centro exhaust air elements.

Common features

Filter class	G2
Max. ambient temperature	40 °C
Width	135 mm
Height	135 mm
Depth	8 mm

**Air filter, replacement
ZRF**

Article	Art. No.
ZRF	0093.0923

- Replacement filter for ER-ZR second room connection kit and for ESG 10/2 internal grille.

Features

Nominal size	100 mm
Filter class	G2
Width	125 mm
Height	125 mm
Depth	10 mm
Packing unit	5 pieces

Planning instructions for ER single air extraction system

Layout example for decentralised air extraction in accordance with DIN 18017-3

Assumption:

- Fans with 60 m³/h in the connecting duct.
- 2 fans per complete floor.
- Building with 11 floors.

Procedure:

- On the diagram (for 2 fans per floor each with 60 m³/h), read the "11 floors" Y-axis - the associated main duct must have a diameter of 225 mm.

ER 60, one unit per complete floor*

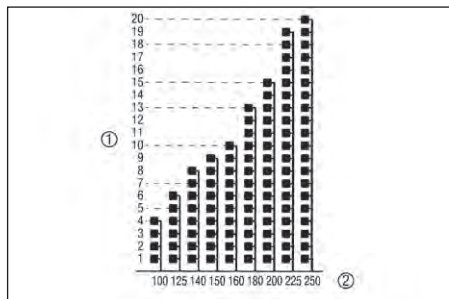

① Number of floors ② Main duct diameter in mm

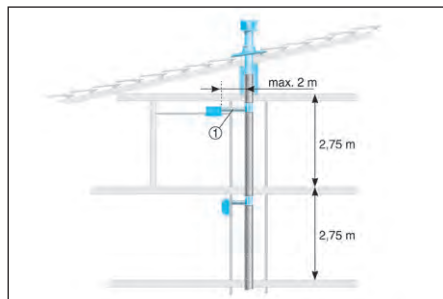

① a maximum of 2 elbows

ER 60, two units per complete floor*

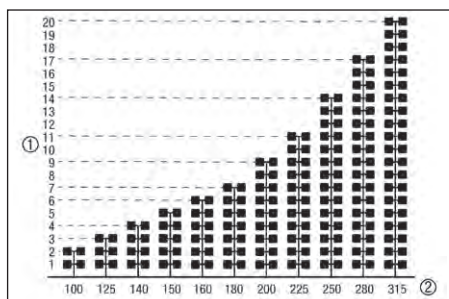

① Number of floors ② Main duct diameter in mm

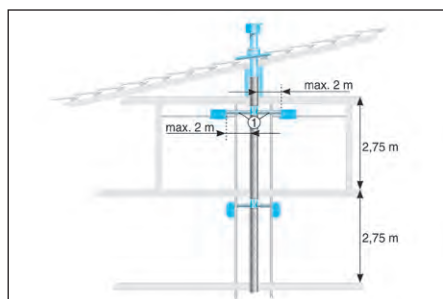

① a maximum of 2 elbows

ER 100, one unit per complete floor*

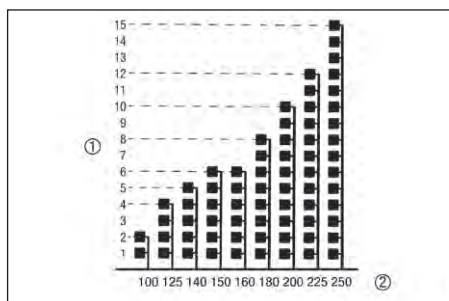

① Number of floors ② Main duct diameter in mm

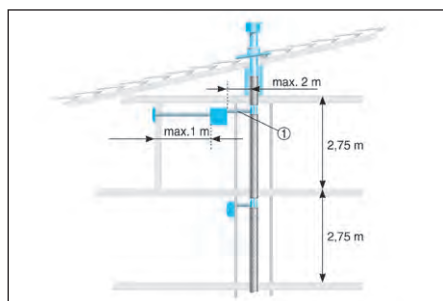

① a maximum of 2 elbows

ER 100, two units per complete floor*

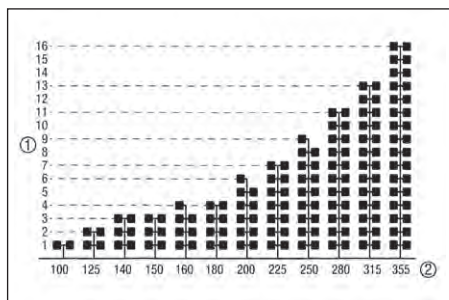

① Number of floors ② Main duct diameter in mm

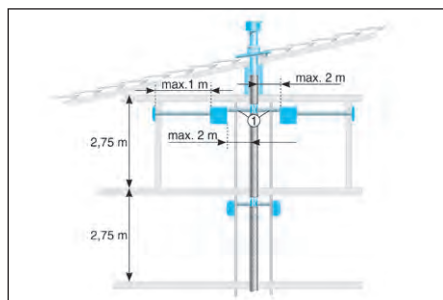

① a maximum of 2 elbows

*Configuration with a coincidence factor of 100 %.

Please note:

- The selection diagrams above do not apply to the Centro centralised ventilation system. Please note separate planning instructions.
- In the event of more stringent acoustic requirements, note flow velocities.

Protection areas in bathrooms in accordance with DIN VDE 0100-701

- Distances to be maintained - protection areas in bathrooms in accordance with DIN VDE 0100-701.
- Bathrooms are divided into 3 areas, in which different requirements apply to the degree of protection required for the electrical equipment.
- If water jets occur in area 1 and 2, select units with an IP X5 degree of protection.
 - All MAICO ER units have the IP X5 degree of protection.

Sector	Permitted voltage	IP-degree of protection for current-using equipment
0	AC 12 V or DC 30 V	IP X7
1	230 V (fans)	IP X5
2	230 V	IP X4, (IP X5 if there is a risk of water jets)

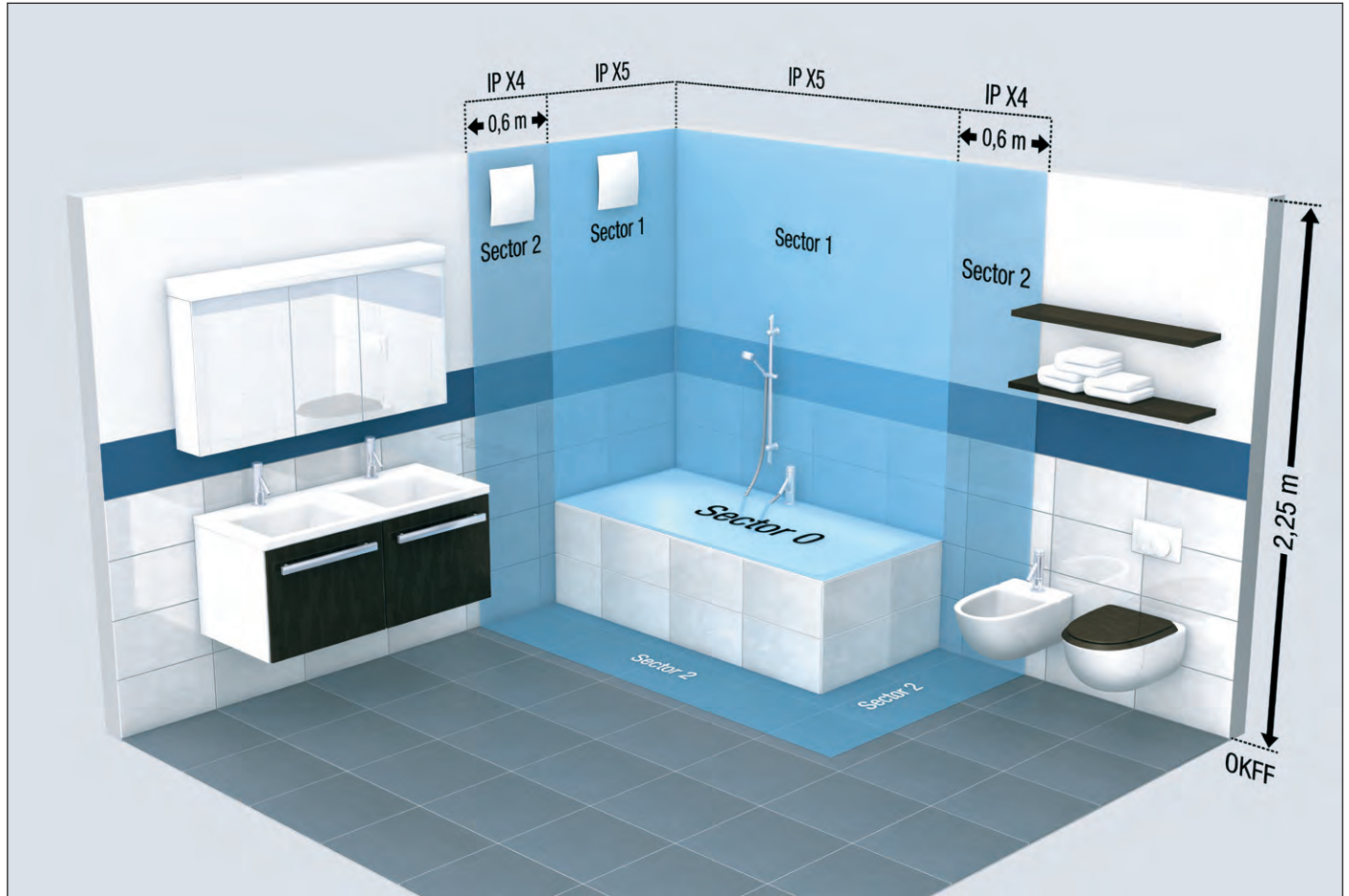

Planning / layout according to DIN 1946-6

- With single and centralised ventilation systems which have building approval for use in accordance with DIN 18017-3, both such systems as well as ventilation systems can be planned and implemented in accordance with DIN 1946-6.
- Do, however, note the different requirements of the respective standards. In particular, fire protection in accordance with DIN 18017-3 is only permitted if the corresponding requirements of DIN 18017-3 and the ventilation system guidelines are met.

Centro centralised ventilation system / GRD centrifugal roof fan



Features

- Pressure or volumetric constancy can be set.
- 2 speed levels for day/night operations.
- Day/night operation can be set using 2 reference volumetric flows or 2 reference pressure levels.
- With automatic fault message.
- Can be used for central ventilation systems in accordance with DIN 18017-3.
- Adjustments can be undertaken without pressure or volumetric flow having to be measured.
- Housing easily detachable for cleaning purposes.
- Galvanized protective grille on the discharge side, protection against accidental contact in accordance with DIN EN ISO 13857.
- Sturdy eyebolts enable transport by crane.

- Impeller with blades curved to the rear, dynamically balanced at two levels, in accordance with performance level 6.3, DIN ISO 1940.
- Impeller made of glass-fibre filled polypropylene.
- With service switch.
- IP 45 degree of protection.

Motor

- EC motor.
- Overload protection as standard.
- No motor protection measures needed.

Electrical connection

- 2 separate mains connections (230 V, 50 Hz) needed for fan and control unit.
- Mains connections 3 x 1.5 mm² each, type NYM-J / NYM-O.
- 6-core shielded control cable between control and fan.
- Control cable with maximum length of 200 m, maximum external diameter of 6 mm, e.g. LiYCY (6 x 0.25 mm² or 6 x 0.34 mm²).

Control unit

▪ **Control unit included in scope of delivery.**

- Any installation inside the building.
- Pressure sensor fitted in fan housing ready for use.
- Control unit for operating in constant pressure / constant volumetric flow mode.
- A minimum volumetric flow is required for the correct function:
 - GRD 22 - 150 m³/h
 - GRD 25 - 200 m³/h
 - GRD 31 - 250 m³/h



Technical data for units > 125 W according to ErP in Best Efficiency Point (BEP)

Article	Art. No.	U _{nom}	f _{nom}	Air flow volume	Sound power level L _{WA5}	Air volume V _{nom}	Pressure P _{fs, nom}	Speed n _{nom}	P _{nom}	I _{nom}	I _{max}	T _{max} at I _{max}	Weight	Efficiency level N	Total efficiency η
		V	Hz	m ³ /h	dB(A)	m ³ /h	Pa	1/min	W	A	A	°C	kg		%
DN 224															
GRD 22	0087.0016	230	50	1,970	75	950 ¹⁾	370 ¹⁾	1,810 ¹⁾	280 ¹⁾	1.7 ¹⁾	1.9	50	27.3	62.4	46.7
DN 250															
GRD 25	0087.0017	230	50	2,690	75	1,370 ¹⁾	390 ¹⁾	1,660 ¹⁾	410 ¹⁾	2.5 ¹⁾	2.6	50	30.7	62.2	47.3
DN 315															
GRD 31	0087.0018	230	50	3,600	74	2,020 ¹⁾	380 ¹⁾	1,490 ¹⁾	600 ¹⁾	3.5 ¹⁾	3.6	50	42.3	65.6	48.8

¹⁾ In opt. efficiency

BEP measured in measurement category C, static efficiency category. VSD integrated. For further ErP data, go online.



Dimensions [mm]

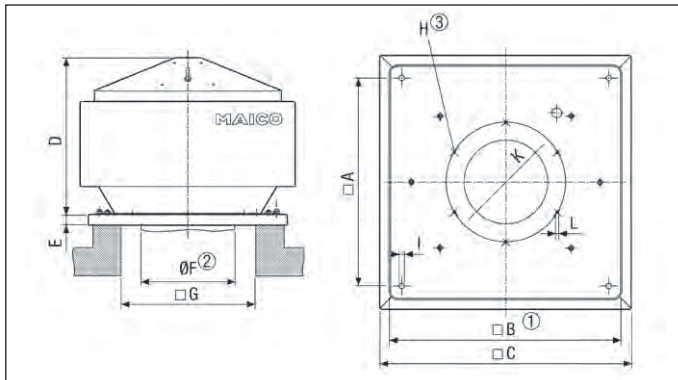

- ① Clear width
- ② External duct diameter
- ③ Number of holes

Article	A	B	C	D	E	F	G	H	I	K	L
GRD 22	460	520	554	407	30	224	340	3	12	259	M6
GRD 25	500	560	614	441	30	250	380	6	12	286	M6
GRD 31	570	630	724	517	30	315	440	8	12	356	M8

Characteristic curves for GRD

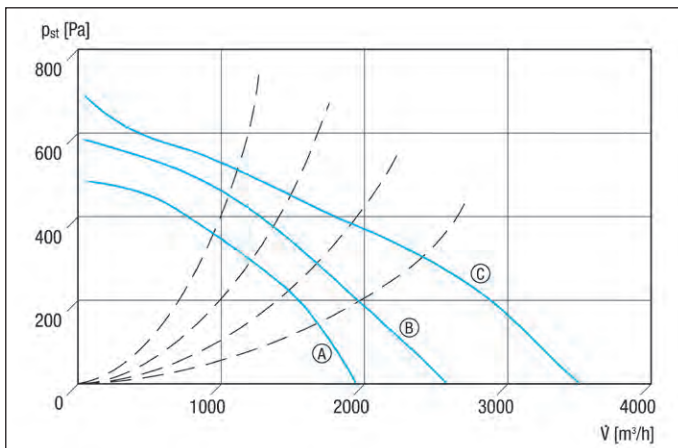

- Ⓐ GRD 22
- Ⓑ GRD 25
- Ⓒ GRD 31

Important accessories

Socket sound absorbers



P. 322

Socket sound absorber for suction side sound insulation of roof fans

SD 22	0092.0338
SD 25	0092.0339
SD 31	0092.0340

Intermediate sockets

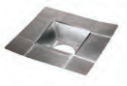

P. 288

For a connection between the SD socket sound absorber and the ventilation ducts that is economical in terms of air flow and easy to mount, for installation in flat roofs

SZ 22	0092.0287
SZ 25	0092.0288
SZ 31	0092.0289

Flexible couplings



P. 220

Flexible couplings for the sound and vibration damped connection of ventilation ducts, with flanges fitted on the fan side, with push-in couplings on the duct side

ELA 22	0092.0282
ELA 25	0092.0266
ELA 31	0092.0284

Roof sockets for flat roofs

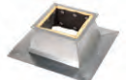

P. 286

Flat roof socket for assembly of roof fans

SO 22	0093.0358
SO 25	0093.0360
SO 30	0093.0361

Roof sockets for flat roofs, tiltable



P. 286

Flat roof socket for assembly of roof fans, with tilting device to move the fan out of the way when working on the ventilation duct

SOK 22	0093.0991
SOK 25	0093.0992
SOK 31	0093.0993

Roof sockets for pitched roofs

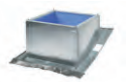

P. 287

Flat roof socket for assembly of roof fans on tiled roofs, standard models for up to 30° roof pitch

SDS 22	0093.0952
SDS 25	0093.0953
SDS 31	0093.0978

Roof sockets for corrugated and trapezoidal roofs



P. 287

Pitched roof socket for assembly of roof fans on corrugated or trapezoidal roofs, standard models for up to 30° roof pitch

SOWT 22	0093.0984
SOWT 25	0093.0985
SOWT 31	0093.0986

**Centro centralised ventilation system / Centro-M / Centro-E /
Centro H exhaust air element**



Features

- Exhaust air element with cover and G2 filter for installation in recessed housings.
- Can be used with Centro centralised ventilation system.
- Fire protection identical with MAICO ER single-room air extraction.
- No cold smoke barriers required.
- No additional sound absorbers required.
- Colour: traffic white, similar to RAL 9016.
- Trouble-free filter change without using tools.
- It is possible to rotate the cover by $\pm 5^\circ$, to compensate for housings which have been fitted at an angle.
- The housing has easy to install snap-in exhaust panels.
- Shaft level difference according to DIN 4109, tested by IAB Oberursel (The Institute for Acoustics and Building Physics in Germany).

Centro-M exhaust air element - manual model

- For centrally modifiable volumetric flow.
- Fixed setting - exhaust element.
- MAICO Centro-M exhaust air elements do not have any electrical connection and can therefore be installed in all areas, in accordance with DIN VDE 0100-701.

Centro-E exhaust air element - electric model

- Exhaust air element with electro-thermal servomotor.
- For basic and demand-based ventilation.
- Pressure controller for centralised fan required.
- Electrical plug connection for quick installation of the exhaust air element in the housing.
- MAICO Centro-E exhaust air elements have an IP X5 degree of protection and can be installed in area 1 in accordance with DIN VDE 0100-701, even with water jets.
- Protection class II.

Centro-H exhaust air element - model with automatic humidity control

- Exhaust air element with electro-thermal servomotor.
- For basic and demand-based ventilation.
- Pressure controller for centralised fan required.
- Electrical plug connection for quick installation of the exhaust air element in the housing.
- MAICO Centro-H exhaust air elements have an IP X5 degree of protection and can be installed in area 1 in accordance with DIN VDE 0100-701, even with water jets.
- Protection class II.
- Barrier-free product as the fan switches itself on and off automatically.
- Switch-on point: 60 %, 70 %, 80 % or 90 % relative humidity can be set with jumper.
- Switch-off point: approx. 10 % below the switch-on point (always a fixed set value).
- Can be operated manually via a switch, e.g. demand-based ventilation using a light switch.
- Standard switching: Closed exhaust air element operation in basic ventilation, humidity control is active when the switch-on point is exceeded - operation in demand-based ventilation, if values fall below switch-off point – operation in basic ventilation.
- Other switching variants: manual activation of demand-based ventilation.
- Activation of full load using light switch and a fan overrun control linked to this (9 minute overrun time).

Technical data

Article	Art. No.	Model	U _{nom} V	f _{nom} Hz	Air flow volume m ³ /h	Power consumption W	I _{max} A	T _{max} at I _{max} °C	Sound pressure level dB(A)	Filter class	Degree of protection IP	Mains cable mm ²
Centro-M	0084.0182	manual	–	–	30/65	–	–	–	26/33 ¹⁾	G2	–	–
Centro-E	0084.0183	electrical	230	50/60	30/65	3	0.9	40	26/33 ¹⁾	G2	X5	3 x 1.5
Centro-H	0084.0187	electrical	230	50/60	30/65	3.5	0.9	40	26/33 ¹⁾	G2	X5	3 x 1.5

¹⁾ Specifications in accordance with DIN 18017-3 at an equivalent absorption area A_L = 10 m.²



Centro centralised ventilation system / Centro-M / Centro-E / Centro H exhaust air element

Dimensions [mm]

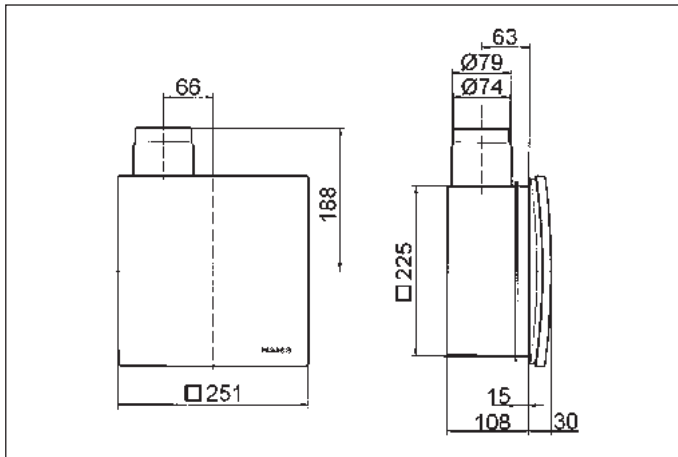

Centro-M / Centro-E / Centro-H exhaust air element with ER-UP/G or ER-UPD recessed-mounted housing

Important accessories

Recessed-mounted housing



P. 58

Recessed-mounted housing with plastic exhaust socket for fitting an ER 60 / ER 100 fan or Centro-M / Centro-E / Centro-H exhaust air element

ER - UP/G 0093.0995

Recessed-mounted housing



P. 60

Recessed-mounted housing with fire protection shut-off device for fitting an ER 60 / ER 100 fan or Centro-M / Centro-E / Centro-H exhaust air element

ER - UPD 0093.0972

Dimensions [mm]

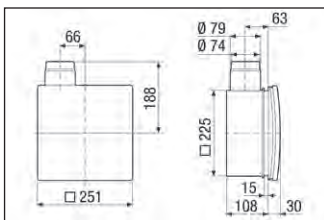

Dimensions [mm]

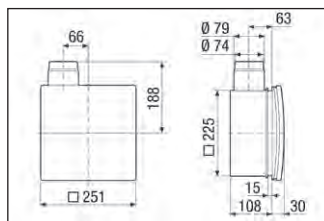

Recessed-mounted housing



P. 62

Recessed-mounted fire protection housing with fire-protection shut-off device for all fire protection systems for insertion of fan units ER 60 / ER 100 or exhaust air elements Centro-M / Centro-E / Centro H

ER - UPB 0093.0968

Dimensions [mm]

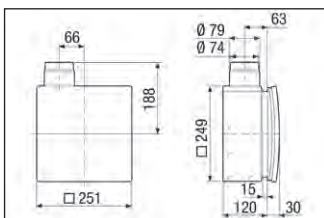

Air filters, replacement

P. 77

Replacement air filter for ER, ER-AP/ APB or Centro, filter class G2

ZF 60/100 0093.0680
ZF 60/100 bulk container 0093.0885

Important accessories

Centrifugal roof fans



P. 00

Centrifugal roof fans with EC motor and integrated control for constant pressure or constant volumetric flow

GRD 22 0087.0016
GRD 25 0087.0017
GRD 31 0087.0018

Centrifugal roof fans



P. 282

Centrifugal roof fan with EC motor

DRD 18 EC 0087.0170
DRD 22 EC 0087.0171
DRD 31 EC 0087.0172

Sound-insulated ventilation boxes



P. 238

Sound-insulated ventilation box with swivelling fan, DN 125 to DN 315

ESR 12-2 EC 0080.0710
ESR 16-2 EC 0080.0711
ESR 20-2 EC 0080.0712
ESR 25-2 EC 0080.0713
ESR 31-2 EC 0080.0714

Pressure and temperature control system



P. 345

Electronic pressure and temperature control system for controlling EC fans in continuously variable manner (i.a. DRD EC and ESR EC)

EAT EC 0157.0119

Differential pressure transmitter



P. 349

Pressure transmitter in plastic housing for use in air and non-aggressive gases

DS 500 0157.0118

Outside air openings



P. 309

Outside air openings for draught-free fresh air supply using outside air

ALD 125 0152.0067
ALD 125 VA 0152.0068

For more models, see page 308.

Dimensions [mm]

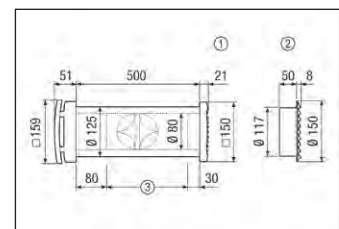

- ① Rectangular plastic external grille ALD 125
- ② Round stainless steel external grille ALD 125 VA
- ③ Shorten to wall thickness if required

Door ventilation grilles



P. 312

Door ventilation grille for bathroom, WC or kitchen

MLK 30 white 0151.0123
MLK 45 white 0151.0126

**Centro centralised ventilation system /
Centro-M-APB / Centro-E-APB exhaust air element, fire protection**



Features

- Surface-mounted design exhaust air element with G2 filter for apartment kitchens, bathroom and WC.
- Can be used with Centro centralised ventilation system.
- Minimum volume flow 30 m³/h.
- Fire protection identical with MAICO ER single-room air extraction.
- Cold smoke barriers as standard.
- No additional telephony sound absorbers required.
- With K90-18017 maintenance-free fire protection shut-off device against spread of fire.
- **Housing can be turned, so the exhaust socket can be connected to main duct in the top left or top right.**
- Colour: traffic white, similar to RAL 9016.
- Trouble-free filter change without using tools.
- DN 75/80 metal exhaust socket with airstream-operated metal backflow preventer.
- Shaft level difference according to DIN 4109, tested by IAB Oberursel (The Institute for Acoustics and Building Physics in Germany).

Centro-M-APB exhaust air element - manual model

- For centrally modifiable volumetric flow.
- Fixed setting - exhaust element.
- MAICO Centro-M-APB exhaust air elements do not have any electrical connection and can therefore be installed in all areas, in accordance with DIN VDE 0100-701.

Centro-E-APB exhaust air element - electric model

- Exhaust air element with electro-thermal servomotor.
- For basic and demand-based ventilation.
- Pressure controller for centralised fan required.
- Electrical plug connection for quick installation of the exhaust air element in the housing.
- MAICO Centro-E APB exhaust air elements have an IP X5 degree of protection and can be installed in area 1 in accordance with DIN VDE 0100-701, even with water jets.
- Protection class II.

Centro-H-APB exhaust air element - model with automatic humidity control

- Exhaust air element with electro-thermal servomotor.
- For basic and demand-based ventilation.
- Pressure controller for centralised fan required.
- Electrical plug connection for quick installation of the exhaust air element in the housing.
- MAICO Centro-H-APB exhaust air elements have an IP X5 degree of protection and can be installed in area 1 in accordance with DIN VDE 0100-701, even with water jets.
- Protection class II.
- Barrier-free product as the fan switches itself on and off automatically.
- Switch-on point: 60 %, 70 %, 80 % or 90 % relative humidity can be set with jumper.
- Switch-off point: approx. 10 % below the switch-on point (always a fixed set value).
- Can be operated manually via a switch, e.g. demand-based ventilation using a light switch.
- Standard switching: Closed exhaust air element operation in basic ventilation, humidity control is active when the switch-on point is exceeded - operation in demand-based ventilation, if values fall below switch-off point – operation in basic ventilation.
- Other switching variants: manual activation of demand-based ventilation.
- Activation of full load using light switch and a fan overrun control linked to this (9 minute overrun time).

Technical data

Article	Art. No.	Model	U _{nom} V	f _{nom} Hz	Air flow volume m ³ /h	Power consumption W	I _{max} A	T _{max} at I _{max} °C	Sound pressure level dB(A)	Filter class	Degree of protection IP	Mains cable mm ²
Centro-M-APB	0084.0184	manual	–	–	30/65	–	–	–	26/33 ¹⁾	G2	–	–
Centro-E-APB	0084.0185	electrical	230	50/60	30/65	3	0.9	40	26/33 ¹⁾	G2	X5	3 x 1.5
Centro-H-APB	0084.0188	electrical	230	50/60	30/65	3.5	0.9	40	26/33 ¹⁾	G2	X5	3 x 1.5

¹⁾ Specifications in accordance with DIN 18017-3 at an equivalent absorption area A_L = 10 m.²

Centro centralised ventilation system / Centro-M-APB / Centro-E-APB exhaust air element, fire protection

Dimensions [mm]

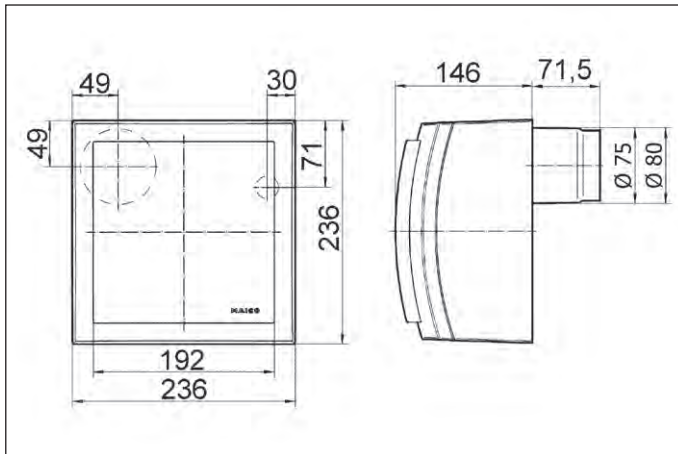

Important accessories

Air filters, replacement

P. 77

Replacement air filter for ER, ER-AP/ APB or Centro, filter class G2

ZF 60/100 0093.0680
ZF 60/100 bulk container 0093.0885

Centrifugal roof fans



P. 80

Centrifugal roof fans with EC motor and integrated control for constant pressure or constant volumetric flow

GRD 22 0087.0016
GRD 25 0087.0017
GRD 31 0087.0018

Centrifugal roof fans



P. 282

Centrifugal roof fan with EC motor

DRD 18 EC 0087.0170
DRD 22 EC 0087.0171
DRD 31 EC 0087.0172

Sound-insulated ventilation boxes



P. 238

Sound-insulated ventilation box with swivelling fan, DN 125 to DN 315

ESR 12-2 EC 0080.0710
ESR 16-2 EC 0080.0711
ESR 20-2 EC 0080.0712
ESR 25-2 EC 0080.0713
ESR 31-2 EC 0080.0714

Pressure and temperature control system



P. 345

Electronic pressure and temperature control system for controlling EC fans in continuously variable manner (i.a. DRD EC and ESR EC)

EAT EC 0157.0119

Differential pressure transmitter



P. 349

Pressure transmitter in plastic housing for use in air and non-aggressive gases

DS 500 0157.0118

Outside air openings



P. 309

Outside air openings for draught-free fresh air supply using outside air

ALD 125 0152.0067
ALD 125 VA 0152.0068

For more models, see page 308.

Dimensions [mm]

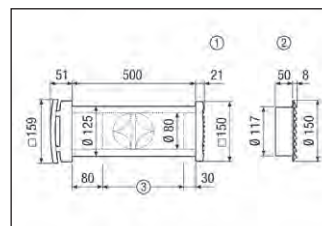

- ① Rectangular plastic external grille ALD 125
- ② Round stainless steel external grille ALD 125 VA
- ③ Shorten to wall thickness if required

Door ventilation grilles



P. 312

Door ventilation grille for bathroom, WC or kitchen

MLK 30 white 0151.0123
MLK 45 white 0151.0126

Further roof sockets on demand.

Planning instructions for Centro central ventilation system



Centro-M dimensioning with GRD roof fan

The details provided in DIN 18017-3 must be observed in order to correctly dimension a system with CENTRO-M. Amongst other things this standard specifies how to calculate the

main duct diameter. At the very least this must be dimensioned such that the exhaust air element furthest away from the fan has no less than 10 % the volumetric flow of that nearest the fan. This

means that the most sealing plugs have to be removed from the bottom exhaust air element. The main duct diameter needed and the number of sealing plugs to be removed depends on the

number of floors and the total number of exhaust air elements used. This can be found in layout diagrams 1 and 2.

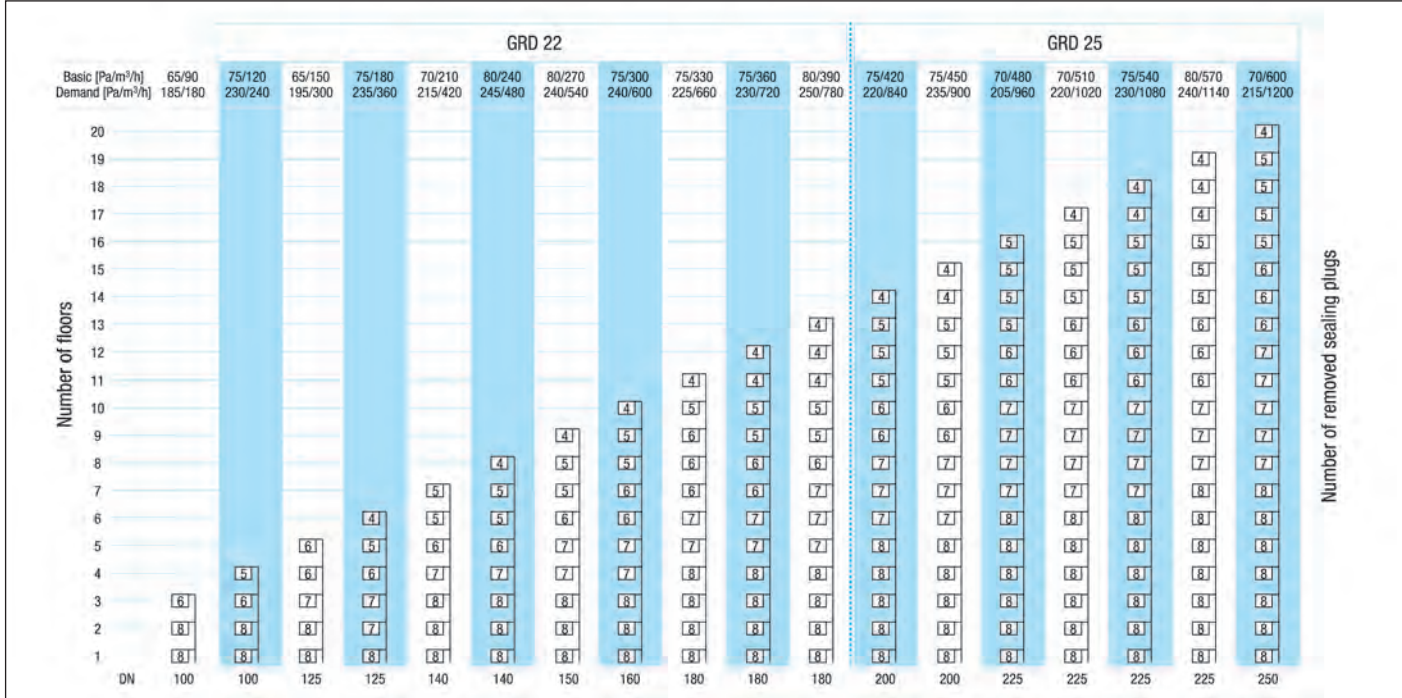

Diagram 1: Layout diagram for branches with **one** exhaust air element per floor

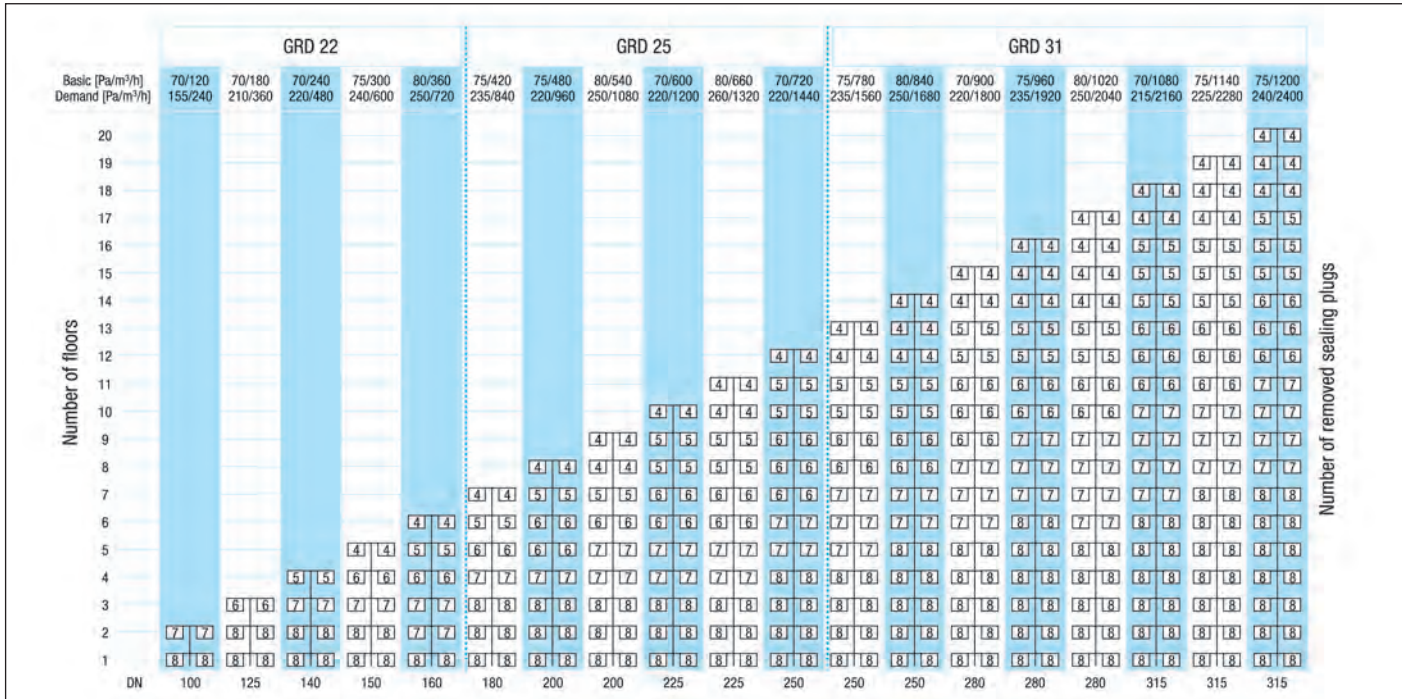
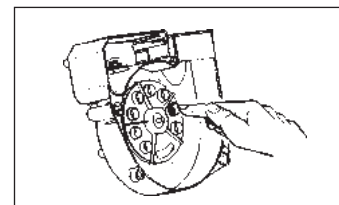

Diagram 2: Layout diagram for branches with **two** exhaust air elements per floor

In the event of more stringent acoustic requirements, note flow velocities.

The sealing plugs can be easily pressed out of the element by hand before the element is placed in the recessed-mounted housing. No tools are needed for this operation.



Centro-E dimensioning with GRD roof fan

The details provided in DIN 18017-3 must be observed in order to correctly dimension a system with CENTRO-E. The diagrams show two real-life scenarios.

1. Two sealing plugs removed, pressure on pressure controller 140 Pa, basic volume around 30 m³/h, on-demand volume around 57 m³/h.

2. Three sealing plugs removed, pressure on pressure controller 110 Pa, basic volume around 30 m³/h, on-demand volume around 49 m³/h. Pressure on pressure controller corresponds

to pressure loss of entire system, i.e. exhaust air element, ducts, elbow etc.

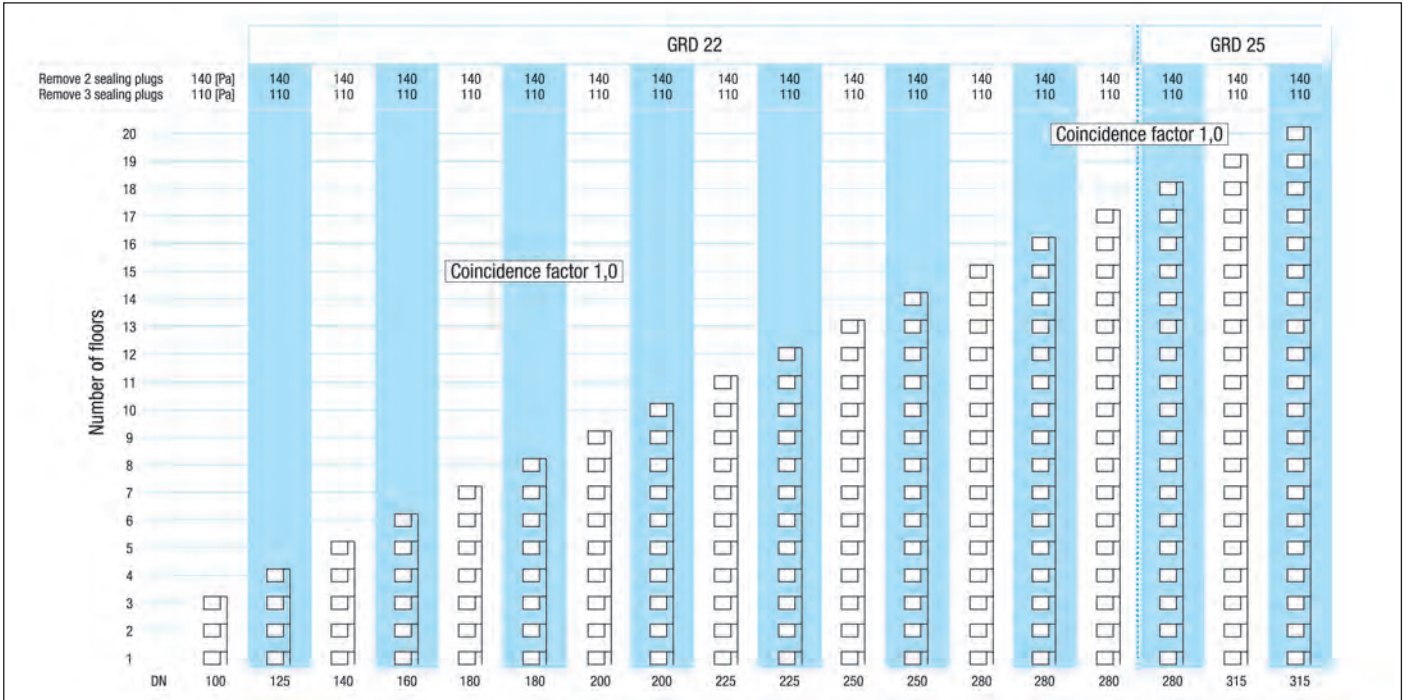

Diagram 1: Layout diagram for branches with **one** exhaust air element per floor

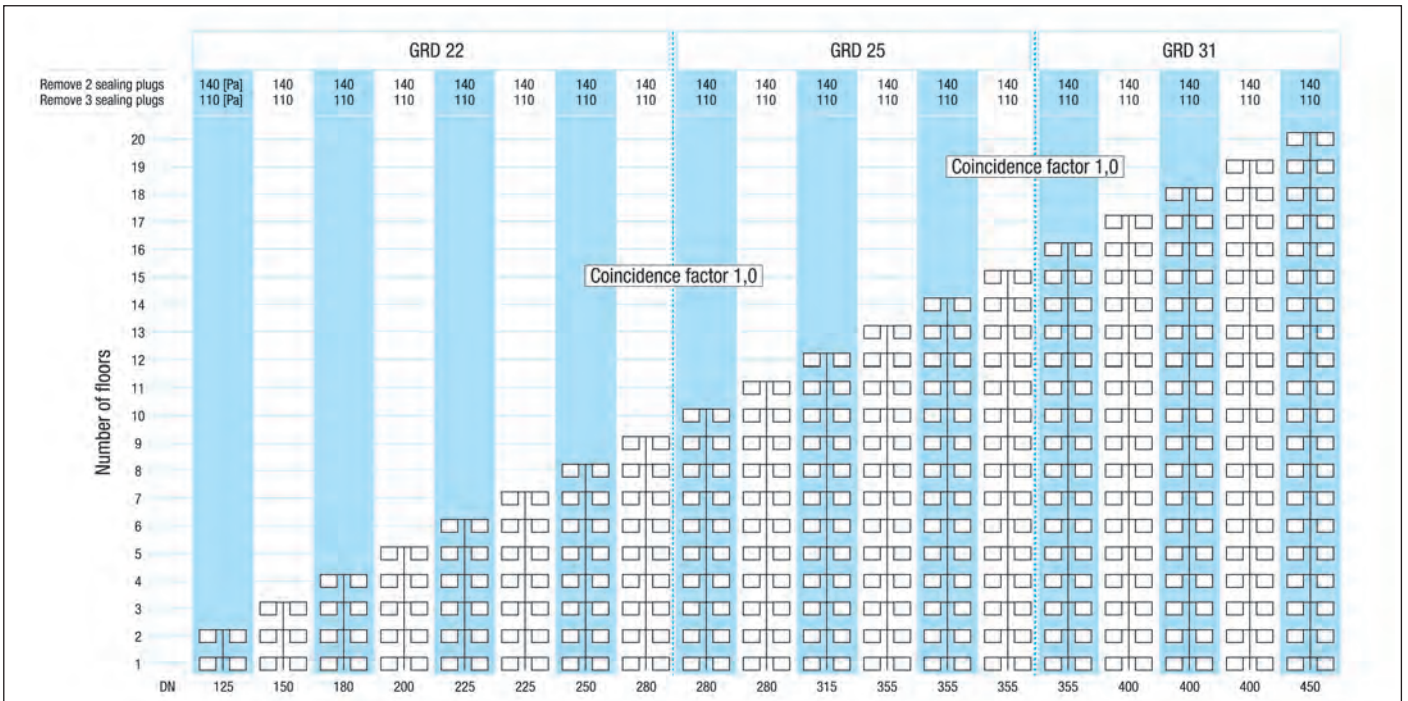
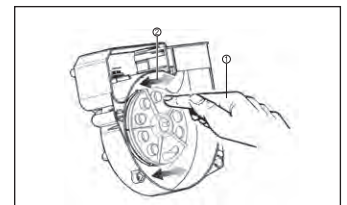

Diagram 2: Layout diagram for branches with **two** exhaust air elements per floor

- ① Basic ventilation by removing 2 or 3 sealing plugs
- ② Demand-based ventilation by electrically adjustable valve plate. Activation by light switch



Exhaust air systems in accordance with DIN 1946-6



Application

Wireless-based exhaust air system MAICOsmart



Page 90

MAICOsmart wireless exhaust air system

ECA 100 ipro RC / ECA 100 ipro RCH small room fan

Quiet fan for the direct removal of the air through the external wall

Page 92

ER RC fan insert

Powerful fan in accordance with DIN 18017-3

Page 94

ECA 150 ipro RC/RCH, ECA 150 ipro KRC/KRCH small room fans

Fan for the direct removal of the air through the external wall

Page 96

Accessories for MAICOsmart



Page 98

Centralised exhaust air units

ZEG2 EC centralised exhaust air unit

Up to 300 m²

NEW!

Page 99

ZEG 2000 P centralised exhaust air unit

Up to 150 m²



Page 101

Accessories for centralised exhaust air units

Page 103

ALD / ZE outside air openings and MLK door ventilation grille



Page 104

Application

MAICOsmart

Wireless-based exhaust air system in accordance with DIN 1946-6



MAICO
smart



Wbutler — enocean®

Inexpensive wireless-based air extraction system according to DIN 1946-6 for redevelopment and the construction of new family houses or apartments, without heat recovery.

MAICO highlights

- Radio-control of the ventilation system by room air control in 3–4 ventilation steps according to DIN 1946-6 (humidity-, reduced-, nominal- and intensive ventilation)
- Room-by-room step switching of the fans via additional radio switches
- Integration of individual air extraction fans according to DIN 18017-3

Operating principle

- Exhaust air
 - ECA or ER in bathroom, toilet, kitchen
- Supply air
 - Intake of outside air via outside air openings in the living rooms

Ventilation components per living unit (example)

- 2–3 exhaust fans ECA or ER with radio receiver
- 1 room air control with radio transmitter
- 4–7 outside air openings ALD 160

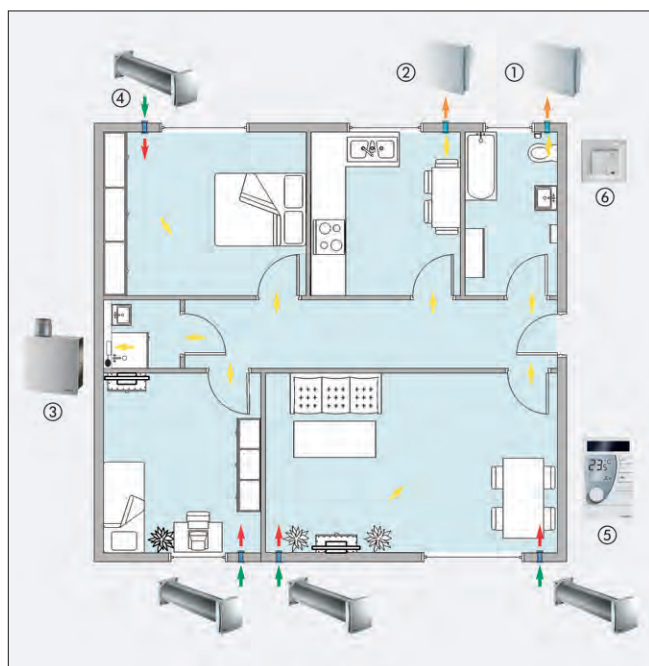

Wbutler | Ventilation for smart homes

- ① Exhaust fan ECA 100 ipro RCH with radio receiver and humidity control
- ② Exhaust fan ECA 100 ipro RC with radio receiver
- ③ Individual air extraction fan ER 100 RC with radio receiver for installations acc. to DIN 18017-3
- ④ Outside air opening ALD
- ⑤ Room air control RLS RC common for all exhaust fans in the flat
- ⑥ Optional additional radio switch DS RC for individual exhaust fans

- Supply air
- Exhaust air
- Outside air
- Outgoing air

Article lists for MAICOsmart

- The MAICOsmart system comprises at least
 - a fan
 - a radio control
 - and several outside air openings.
- The number of outside air openings depends on the size of the space requiring ventilation and the fans fitted.
- On the ECA 100 ipro RC/RCH and ER 100 RC product page on the website you can automatically have combined the items you need to suit the size of your home.

ECA 100 ipro RC		The number of components depends on the apartment size						
Component	Art. No.	≤ 30 m ²	50 m ²	70 m ²	90 m ²	110 m ²	130 m ²	140 m ²
ECA 100 ipro RC	0084.0210	1	1	2	2	3	3	3
RLS RC	0157.0849	1	1	1	1	1	1	1
ALD 125	0152.0067	3	3	4	5	7	7	7
MLK 45 white	0151.0126	1	2	3	5	5	6	6
WH 100	0059.1030	1	1	2	2	3	3	3
AP 100	0059.1058	1	1	2	2	3	3	3
		List 1	List 2	List 3	List 4	List 5	List 6	List 7

ECA 100 ipro RCH		The number of components depends on the apartment size						
Component	Art. No.	≤ 30 m ²	50 m ²	70 m ²	90 m ²	110 m ²	130 m ²	140 m ²
ECA 100 ipro RCH	0084.0211	1	1	2	2	3	3	3
RLS RC	0157.0849	1	1	1	1	1	1	1
ALD 125	0152.0067	3	3	4	5	7	7	7
MLK 45 white	0151.0126	1	2	3	5	5	6	6
WH 100	0059.1030	1	1	2	2	3	3	3
AP 100	0059.1058	1	1	2	2	3	3	3
		List 8	List 9	List 10	List 11	List 12	List 13	List 14

ER 100 RC		The number of components depends on the apartment size						
Component	Art. No.	≤ 30 m ²	50 m ²	70 m ²	90 m ²	110 m ²	130 m ²	140 m ²
ER 100 RC	0084.0129	1	1	1	2	2	2	2
RLS RC	0157.0849	1	1	1	1	1	1	1
ALD 125	0152.0067	3	3	3	5	5	7	7
MLK 45 white	0151.0126	1	2	3	5	5	6	6
ER-UP/G	0093.0995	1	1	1	2	2	2	2
		List 15	List 16	List 17	List 18	List 19	List 20	List 21

**MAICOsmart wireless exhaust air system /
ECA 100 ipro RC / ECA 100 ipro RCH small room fan**



Features

- Radio-controlled fan for the MAICOsmart exhaust air system, with inbuilt 868 MHz radio receiver, based on EnOcean technology.
- The fan can be installed in a master/slave network (RLS RC needed).
- Two performance levels.
- Designer cover conceals the inlet.
- For air extraction.
- With VDE symbol.
- IP X5 degree of protection for safety in the bathroom.
- Protection class II.
- Colour: traffic white, similar to RAL 9016.
- Housing made of impact resistant plastic material.
- Can be combined with Wibutler smart home system.

Motor

- Energy-saving robust motor with ball bearings, maintenance-free.
- Suitable for continuous operation.

Mounting instructions

- Simplest installation as the cover can be removed easily with tools.
- Compatible with ECA predecessor models DN 100, because screw holes and cable entry are in the same place.

Electrical connection

- Recessed mounted electrical connection.

Security instructions

- The fans have an IP X5 degree of protection and can be installed in protection area 1 in accordance with DIN VDE 0100-701.
- For details, see planning instructions in chapter on small room fans.

The following models are available:

RC Model with radio receiver

- With integrated 868 MHz radio receiver.
- On/off via DS RC radio switch or separate RLS RC control.
- The two speeds can be selected either on the radio switch or control.
- Not speed-controllable.

RCH Model with radio receiver and humidity control

- With integrated 868 MHz radio receiver and humidity control.
- Barrier-free product as the fan switches itself on and off via the humidity sensor.
- Switch-on humidity does not have to be set. Fan monitors humidity curve. Automatic air extraction depending on room humidity, at level 1 or 2.
- Can be switched with separate DS RC radio switch or separate RLS RC control.
- The two speeds can be selected either on the radio switch or control.
- Not speed-controllable.

Technical data

Article	Art. No.	Model	U _{nom} V	f _{nom} Hz	Air flow volume m ³ /h	Rotating speed 1/min	Power consumption W	I _{max} A	T _{max} at I _{max} °C	Sound pressure level dB(A)	Degree of protection IP	Mains cable mm ²
ECA 100 ipro RC	0084.0210	Radio receiver	230	50	78/92	2,100/2,500	6/8	0.06	40	27/32 ¹⁾	X5	3 x 1.5
ECA 100 ipro RCH	0084.0211	Radio receiver and humidity control	230	50	78/92	2,100/2,500	6/8	0.06	40	27/32 ¹⁾	X5	3 x 1.5

¹⁾ Distance 3 m, Free-field conditions



MAICOsmart wireless exhaust air system / ECA 100 ipro RC / ECA 100 ipro RCH small room fan

Dimensions [mm]

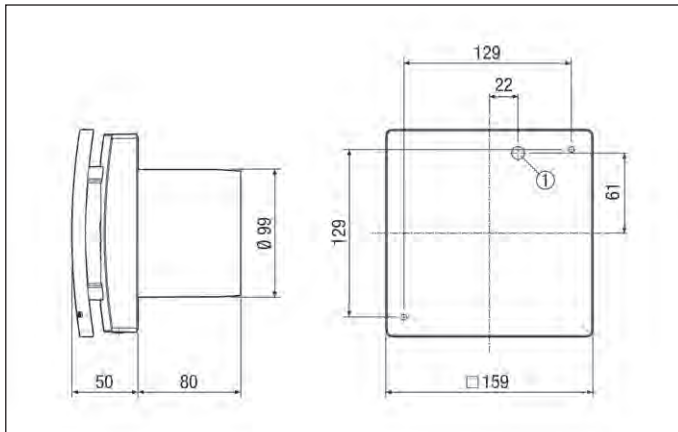

① Cable entry

Characteristic curve

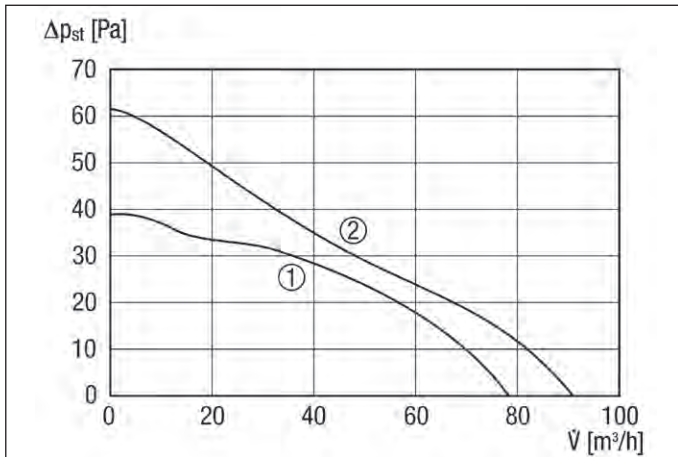

① Performance level 1
② Performance level 2

Important accessories

Room air control



P. 98

Room air control for MAICOsmart wireless exhaust air system

RLS RC 0157.0849

Radio switch



P. 98

Radio switch for wirelessly switching ECA ... ipro RC/RCH and ER 100 RC fans

DS RC 0157.0832

Outside air openings



P. 104

Outside air openings for draught-free fresh air supply using outside air

ALD 125 0152.0067
ALD 125 VA 0152.0068

For more models, see page 104.

Dimensions [mm]

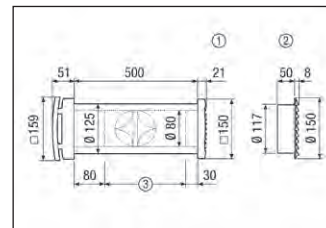

① Rectangular plastic external grille ALD 125
② Round stainless steel external grille ALD 125 VA
③ Shorten to wall thickness if required

Accessories selection table

	ECA 100 ipro RC	ECA 100 ipro RCH	see
Window installation kit	FE 100/1 AP FE 100/1 SG	FE 100/1 AP FE 100/1 SG	P. 23
Mounting plate	ZM 11	ZM 11	P. 39
Spacing frame	ECA-DR	ECA-DR	P. 39
Room air control	RLS RC	RLS RC	P. 98
Radio switch	DS RC	DS RC	P. 98
Shutter	AP 100 AP 100 B	AP 100 AP 100 B	P. 296
External grille	SG 100 SG 100 B	SG 100 SG 100 B	P. 303
Wall sleeve	WH 100	WH 100	P. 179
Outside air opening	ALD 10 ALD 125 ALD 125 VA ALD 160 ALD 160 VA	ALD 10 ALD 125 ALD 125 VA ALD 160 ALD 160 VA	P. 104
Roof outlet	DF 125..*	DF 125..*	P. 306
Roofing tile	DP 125..*	DP 125..*	P. 306
Mounting clamp	BS 125*	BS 125*	P. 306
Rain protection grille	RG 125*	RG 125*	P. 306
Door ventilation grille	MLK 30 white MLK 45 white	MLK 30 white MLK 45 white	P. 105
Flexible aluminium duct	AFR 100	AFR 100	P. 319

*Customer must purchase reducer



Features

- Radio-controlled fan for the MAICOsmart exhaust air system, with G2 filter and inbuilt 868 MHz radio receiver, based on EnOcean technology.
- The fan can be installed in a master/slave network (RLS RC needed).
- Three performance levels 35 / 60 / 100 m³/h.
- Fan with cover and filter for installation in recessed housings.
- Trouble-free filter change without using tools.
- It is possible to rotate the cover by ± 5°, to compensate for housings which have been fitted at an angle.
- Protection class II.
- With VDE symbol.
- Can be combined with Wibus smart home system.

Motor

- Energy-saving robust capacitor motor with ball bearings, maintenance-free.
- Suitable for continuous operation.

Security instructions

- The fan has an IP X5 degree of protection and can be installed in protection area 1 in accordance with DIN VDE 0100-701, even with water jets.
- For details see planning instructions in chapter on single-duct air extraction according to DIN 18017-3.

RC Model with radio receiver

- On/off via DS RC radio switch or separate RLS RC control.
- Overrun time of around 15 min only when switching off in single mode with radio switch and deactivated DIN 18017-3 mode.
- The three speeds can be selected either on the radio switch or control.
- Not speed-controllable.

Technical data

Article	Art. No.	Model	U _{nom} V	f _{nom} Hz	Rotating speed 1/min	Air flow volume m ³ /h	Power consumption W	I _{max} A	T _{max} at I _{max} °C	Sound pressure level dB(A)	Sound power level L _{WA7} dB(A)	Filter class	Degree of protection IP	Mains cable mm ²
ER 100 RC	0084.0129	Radio receiver	230	50	850/1,250/1,900	35/60/100	10/21/29.5	0.1/0.12/0.14	40	27/36/45 ¹⁾	31/40/49	G2	X5	3 x 1.5

¹⁾ Specifications in accordance with DIN 18017-3 at an equivalent absorption area A_e = 10 m.²



Dimensions [mm]

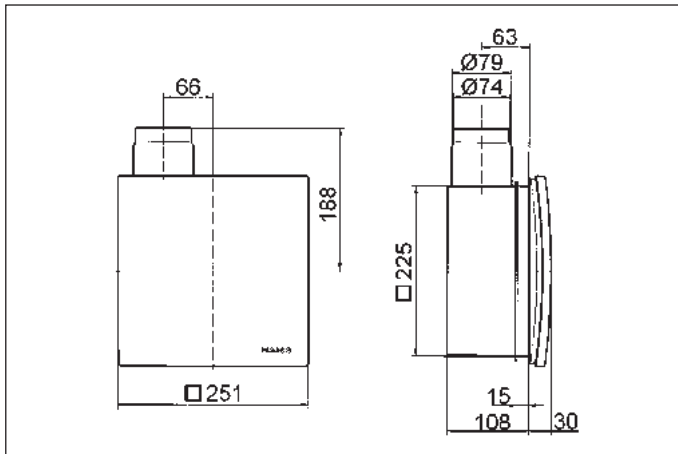

ER fan insert with recessed-mounted housing ER-UP/G or ER-UPD

Dimensions [mm]

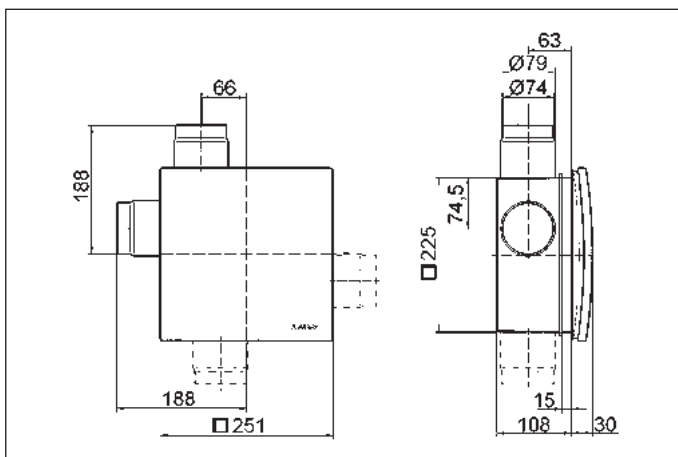

ER fan insert with recessed-mounted housing ER-UP/G or ER-UPD and second room connection

Characteristic curve

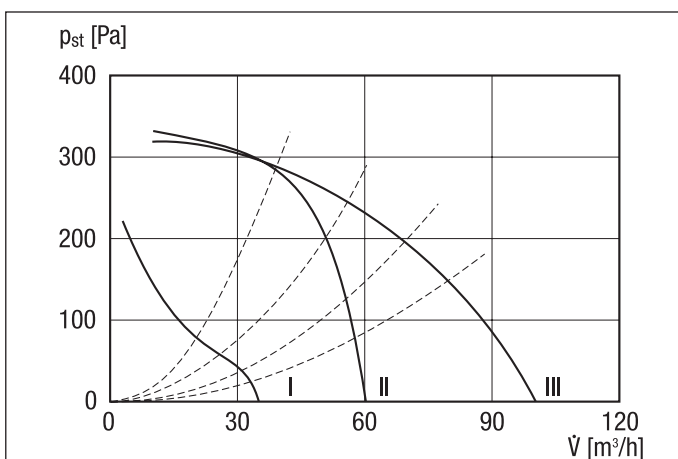

Important accessories

Room air control



P. 98

Room air control for MAICOsmart wireless exhaust air system

RLS RC

0157.0849

Radio switch



P. 98

Radio switch for wirelessly switching ER 100 RC and ECA ... ipro RC/RCH fans

DS RC

0157.0832

Outside air openings



P. 104

Outside air openings for draught-free fresh air supply using outside air

ALD 125

0152.0067

ALD 125 VA

0152.0068

For more models, see page 104.

Dimensions [mm]

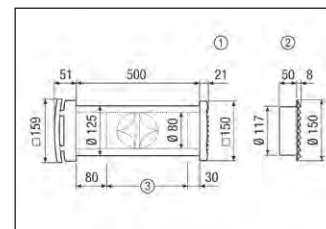

① Rectangular plastic external grille

ALD 125

② Round stainless steel external grille

ALD 125 VA

③ Shorten to wall thickness if required

Accessories selection table

	ER 100 RC	see
Recessed-mounted housing	ER-UP/G ER-UPD ER-UPB	P. 58
Air filter, replacement	ZF 60/100 ZF 60/100 bulk container	P. 77
Masking frame	ER-AR	P. 64
Spacing frame	DR 60/100	P. 64
Second room extraction system	ER-ZR	P. 65
Room air control	RLS RC	P. 98
Radio switch	DS RC	P. 98
Outside air opening	ALD 10 ALD 125 ALD 125 VA ALD 160 ALD 160 VA	P. 104
Roof outlet	DF	P. 306
Roofing tile	DP	P. 306
Mounting clamp	BS	P. 306
Rain protection grille	RG	P. 306
Door ventilation grille	MLK 30 white MLK 45 white	P. 105
Flexible aluminium duct	AFR	P. 319

**MAICOsmart wireless exhaust air system /
ECA 150 ipro RC / RCH, ECA 150 ipro KRC / KRCH small room fan**



Features

- Radio-controlled fan for the MAICOsmart exhaust air system, with inbuilt 868 MHz radio receiver, based on EnOcean technology.
- The fan can be operated with a double toggle switch (DS RC) (no need to route cable between switch and fan).

- The fan can be installed in a master/slave network with other ECA 150 ipro RC/RCH/KRC/KRCH (RLS RC needed). A combination of ECA 150 ipro RC/RCH/KRC/KRCH with ECA 100 ipro RC/RCH or ER 100 RC is **not** possible.
- Two performance levels.
- Designer cover conceals the inlet.
- For air extraction.
- With VDE GS symbol.
- IP X5 degree of protection for safety in the bathroom.
- Protection class II.
- Colour: traffic white, similar to RAL 9016.
- Housing made of impact resistant plastic material.

Motor

- Energy-saving robust motor with ball bearings, maintenance-free.
- Suitable for continuous operation.

Mounting instructions

- Simplest installation as the cover can be removed easily with tools.
- Compatible with ECA predecessor models DN 150, because recessed screw holes and cable entry are in the same place.

Electrical connection

- Recessed mounted electrical connection.

Security instructions

- The fans have an IP X5 degree of protection and can be installed in protection area 1 in accordance with DIN VDE 0100-701.
- For details, see planning instructions in chapter on small room fans.

The following models are available:

Either as fixed internal grille or K version (ECA 150 ipro K...) with electrically operated internal shutter.

RC Model with radio receiver

- With integrated 868 MHz radio receiver.
- On/off via DS RC radio switch or separate RLS RC control.
- The two speeds can be selected either on the radio switch or control.
- Not speed-controllable.

RCH Model with radio receiver and humidity control

- With integrated 868 MHz radio receiver and humidity control.
- Barrier-free product as the fan switches itself on and off via the humidity sensor.

- Switch-on humidity does not have to be set. Fan monitors humidity curve. Automatic air extraction depending on room humidity, at level 1 or 2.
- Can be switched with separate DS RC radio switch or separate RLS RC control.

- The two speeds can be selected either on the radio switch or control.
- Not speed-controllable.

Technical data

Article	Art. No.	Model	U _{nom}	f _{nom}	Rotating speed 1/min	Air flow volume m ³ /h	Power consumption W	I _{max}	T _{max} at I _{max}	Sound pressure level dB(A)	Degree of protection IP	Mains cable mm ²
			V	Hz				A	°C			
ECA 150 ipro RC	0084.0087	Radio receiver	230	50	1,672/2,189	200/250	15/19	0.09	40	33/40 ¹⁾	X5	5 x 1.5
ECA 150 ipro RCH	0084.0088	Radio receiver and humidity control	230	50	1,672/2,189	200/250	15/19	0.09	40	33/40 ¹⁾	X5	5 x 1.5
ECA 150 ipro KRC	0084.0093	Radio receiver	230	50	1,672/2,189	200/250	18/22	0.11	40	33/40 ¹⁾	X5	3 x 1.5
ECA 150 ipro KRCH	0084.0094	Radio receiver and humidity control	230	50	1,672/2,189	200/250	18/22	0.11	40	33/40 ¹⁾	X5	3 x 1.5

¹⁾ Distance 3 m, Free-field conditions



MAICOsmart wireless exhaust air system / ECA 150 ipro RC / RCH, ECA 150 ipro KRC / KRCH small room fan

Dimensions [mm]

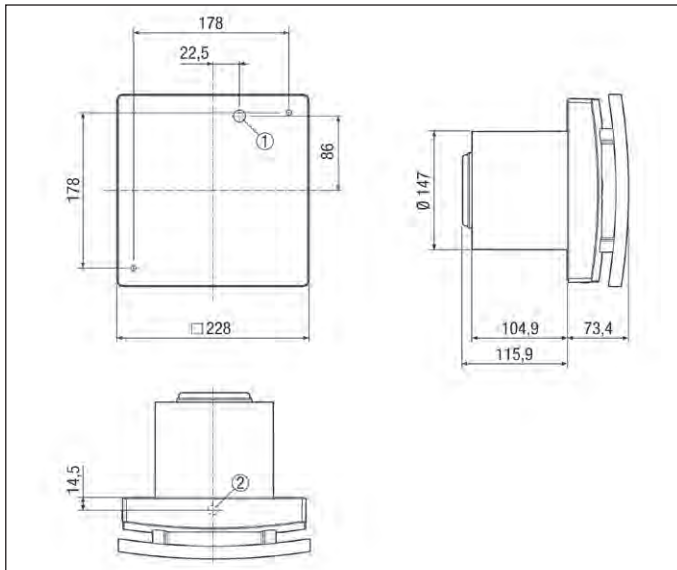

- ① Cable entry for recessed-mounted connection
② Cable bushing for surface-mounted connection

Characteristic curve

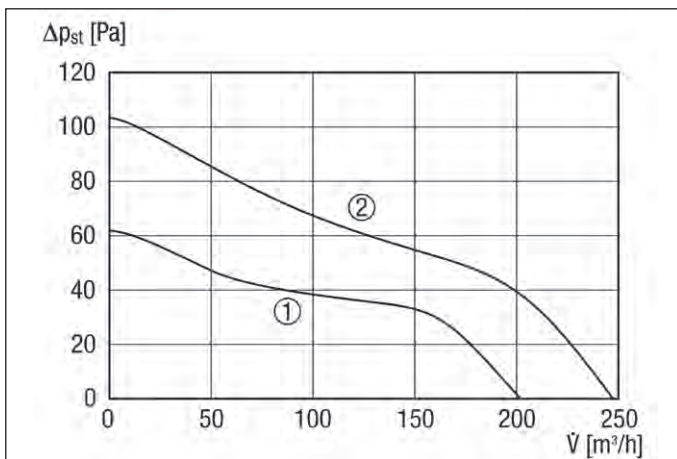

- ① Performance level 1
② Performance level 2

Important accessories

Room air control



P. 98

Room air control for MAICOsmart wireless exhaust air system

RLS RC 0157.0849

Radio switch



P. 98

Radio switch for wirelessly switching ECA ... ipro RC/RCH and ER 100 RC fans

DS RC 0157.0832

Outside air openings



P. 104

Outside air openings for draught-free fresh air supply using outside air

ALD 125 0152.0067
ALD 125 VA 0152.0068

For more models, see page 104.

Dimensions [mm]

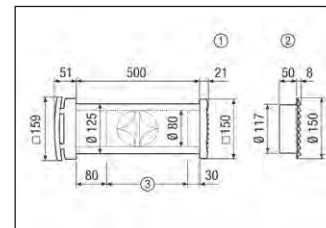

- ① Rectangular plastic external grille ALD 125
② Round stainless steel external grille ALD 125 VA
③ Shorten to wall thickness if required

Accessories selection table

	ECA 150 ipro RC	ECA 150 ipro RCH	ECA 150 ipro KRC	ECA 150 ipro KRCH	see
Spacing frame	ECA15-EMA16	ECA15-EMA16	ECA15-EMA16	ECA15-EMA16	P. 39
Room air control	RLS RC	RLS RC	RLS RC	RLS RC	P. 98
Radio switch	DS RC	DS RC	DS RC	DS RC	P. 98
Shutter	AP 150	AP 150	AP 150	AP 150	P. 296
External grille	SG 15	SG 15	SG 15	SG 15	P. 303
Wall sleeve	WH 150	WH 150	WH 150	WH 150	P. 179
Outside air opening	ALD 10 ALD 125 ALD 125 VA ALD 160 ALD 160 VA	ALD 10 ALD 125 ALD 125 VA ALD 160 ALD 160 VA	ALD 10 ALD 125 ALD 125 VA ALD 160 ALD 160 VA	ALD 10 ALD 125 ALD 125 VA ALD 160 ALD 160 VA	P. 104
Roof outlet	DF 160..*	DF 160..*	DF 160..*	DF 160..*	P. 306
Roofing tile	DP 160..*	DP 160..*	DP 160..*	DP 160..*	P. 306
Mounting clamp	BS 160*	BS 160*	BS 160*	BS 160*	P. 306
Rain protection grille	RG 160*	RG 160*	RG 160*	RG 160*	P. 306
Door ventilation grille	MLK 30 white MLK 45 white	MLK 30 white MLK 45 white	MLK 30 white MLK 45 white	MLK 30 white MLK 45 white	P. 105
Flexible aluminium duct	AFR 150	AFR 150	AFR 150	AFR 150	P. 319

*Adaptation by the customer needed

**Room air control
RLS RC**



Article **Art. No.**
RLS RC **0157.0849**



- Radio control for MAICOsmart wireless exhaust air system.
- For wireless activation of ECA ... ipro RC/RCH and ER 100 RC fans.
- Power supplied by an integrated solar cell and buffer battery.
- The following ventilation levels can be selected on the control:
 - Ventilation levels 1 to 3 - from low when people are out during the day to high for a rapid air exchange.
- Vacation mode: During long periods of absence, an interval operation activates the fans.
- The RLS RC radio control features the following setting options:
 - The filter change display interval can be set to between 2 and 6 months.
 - Stop function should the room temperature fall below a preset level.
 - System level 0 can be deactivated such that the ventilation system always extracts air, offering at least ventilation for humidity protection. This function is also needed in conjunction with DIN 18017-3 systems.
 - The RLS RC is always set up on the master fan.
 - No connecting duct so can be fitted anywhere.
 - Fit in an illuminated room.

Features

Battery	AA Lithium, 3.6 V
Degree of protection	IP 30
Mains cable	not required
Material	Synthetic material
Transmission range in the building	30 m
Colour	Traffic white, similar to RAL 9016
Type of installation	Surface-mounted
Installation site	Wall
Installation site	room illuminated at times
Width	94 mm
Height	153 mm
Depth	20 mm

**Radio switch
DS RC**



Article **Art. No.**
DS RC **0157.0832**



- EnOcean radio switch.
- The radio switch can be used individually with the ECA ... ipro RC/RCH, ER 100 RC fans or the MAICOsmart system.
- The radio switch can also be used in combination with the EnOcean plug-in module E-SM in order to control the WS 160 Flat, WS 170 KBR...WS 170 KBL..., WS 320/470 and WR 310/410 centralised ventilation units using EnOcean.
- For redevelopments and retrofit installations – no painting or wallpapering.
- Tiles don't need to be removed or renewed.
- Application wherever no control cable can be installed.
- Radio switch can be used on the move.
- Radio switch requires no batteries.
- Radio switch can be screwed on or attached to a glass surface.
- Simple transmitter teaching-in saves on time-consuming programming.

Features

Battery	not required
Degree of protection	IP 20
Material	Synthetic material
Colour	Pure white, similar to RAL 9010
Type of installation	Surface-mounted
Installation site	Wall
Mains cable	not required
Ambient temperature	-25 °C up to 65 °C
Width	83 mm
Height	83 mm
Depth	16 mm
Transmission range in the building	30 m
Radio frequency	868.3 MHz

Features

- Centralised air extraction unit
- For simultaneous air extraction of a number of rooms in single family-unit houses or flats.
- IP 20 degree of protection.
- Easy-to-clean housing.
- The unit is fitted with a quiet-running and energy-efficient electric motor.
- With 5 possible exhaust air connections (3 x DN 125, 1 x DN 125/DN 160) and 1 x DN 160 = "knockout point")
- With a DN 125 outgoing air socket.
- Motor and electronics are integrated.
- Max. 28 speed levels are available.
- Levels 1(a*) = "Low", 3(a*) = "Normal" and 11 (a*) = "High" are preset as standard.
- The preset speed levels can be easily changed using what are known as DIP switches.
- With integrated humidity sensor for automatic humidity-dependent activation.
- **ZEG2 EC-FB wireless remote control included in scope of delivery.**
- * = the "a" characteristic curve and "b" characteristic curve exist depending on the setting of DIP switch 7.

Controller

- ZEG2 EC-FB wireless remote control with humidity sensor activation and 6 setting buttons (humidity sensor is contained in ZEG2 EC).
- Radio frequency 868.3 MHz.
- Dimensions (HxWxD): 83x80x28 mm.
- Degree of protection: IP 30.
- LED status display.
- Settings
 - Operation during periods of absence ('energy-saving mode')
 - Automatic operation regulates the ventilation level in accordance with the humidity sensor measurements established
 - Timer operation (15/30/60 minutes) in 'High' level – then back to the last level selected
 - 1. Low speed – standard position during the night
 - 2. Normal speed – standard position during the day
 - 3. High speed – when cooking and showering

- About automatic mode: In this position the exhaust air unit runs at a lower speed until a significant increase in the relative air humidity in the exhaust air is measured within 3 minutes (can be set to 5 % or 10 % with DIP switch 7). The unit then switches from the "Low" (1) level to "Normal" (2) or "High" (3) depending on setting of DIP switch 7. If there is a noticeable drop in the humidity level, the ZEG2 EC runs for 15 or 30 minutes at 'Normal' or 'High' level (overrun time is set with DIP switch 8). It then switches back to 'Low' level.
- About operation during periods of absence: The ZEG2 EC runs in energy save mode and does not react to the humidity sensor

Mounting instructions

- The ZEG2 EC-FB remote control can be installed in damp rooms - but not in the shower cubicle itself. The remote control must not be sprayed (relative humidity of max. 90 %).
- The ZEG2 EC unit must be installed in a dry room - it must not come into contact with any spray (relative humidity of max. 90 %).

Electrical connection

- Flexible connecting cable, approx. 1.2 m long.

Technical data

Article	Art. No.	U _{nom}	f _{nom}	Connection diameter	Air flow volume	Power consumption	I _{max}	Sound power level	Degree of protection	Weight
		V	Hz	mm	m ³ /h	W	A	L _{WA2} dB(A)	IP	kg
ZEG2 EC	0086.0206	230	50	125	535/600 ¹⁾	2 - 85	0.05 - 0.8	28 - 46 ²⁾	20	4.6

¹⁾ System pressure at 200 Pa and/or system pressure at 100 Pa

²⁾ Measured in accordance with factory setting (3 levels)

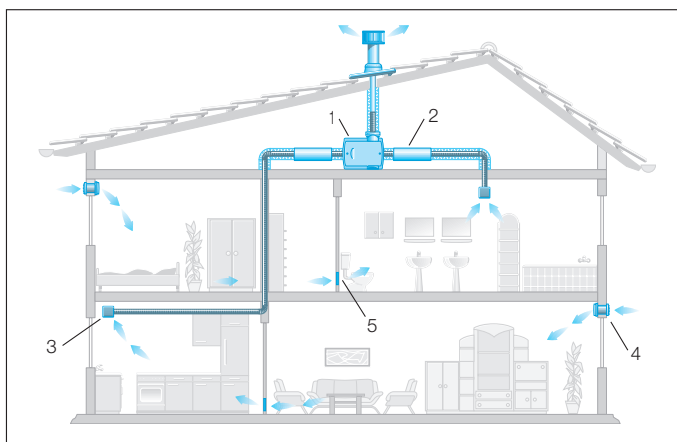

- 1 Exhaust air unit ZEG
- 2 Tubular sound absorber RSR
- 3 Exhaust air valve AZV
- 4 Outside air opening ALD
- 5 Door ventilation grille MLK

Features

- Central ventilation unit.
- For simultaneous air extraction of a number of rooms in single family-unit houses or apartments.
- High pressure through centrifugal impeller.
- Supply air intake by means of decentralised outside air openings, e.g. ALDs.
- 3 ventilation levels can be set.
- Up to 3 intake sockets for exhaust air, suitable for ducts with DN 125. The intake sockets can be broken-out if need be.
- 1 DN 125 exhaust socket for outgoing air.

Motor

- Motor designed for continuous operation.
- Thermal overload protection as standard feature.

Mounting instructions

- The housing can be fastened in any position to beams, walls or ceilings.

Electrical connection

- When delivered, the device is assembled and ready for service.

Technical data

Article	Art. No.	U _{nom} V	Connection diameter mm	Rotating speed 1/min	Air flow volume m ³ /h	Power consumption W	I _{max} A	Sound pressure level dB(A)	Degree of protection IP	Weight kg
ZEG 2000 P	0086.0203	230	125	1,825	310 ¹⁾	14/42/92	0.14/0.3/0.4	33/41/49	20	3.4

¹⁾ System pressure at 100 Pa

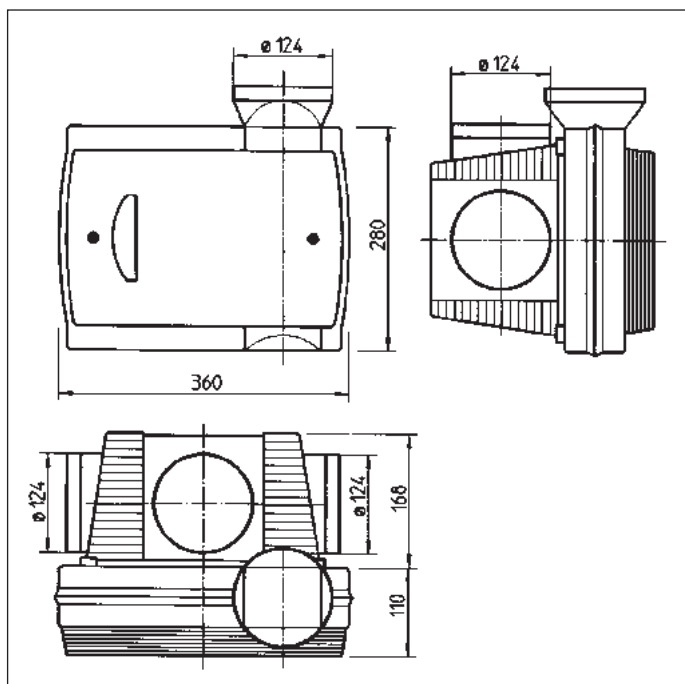
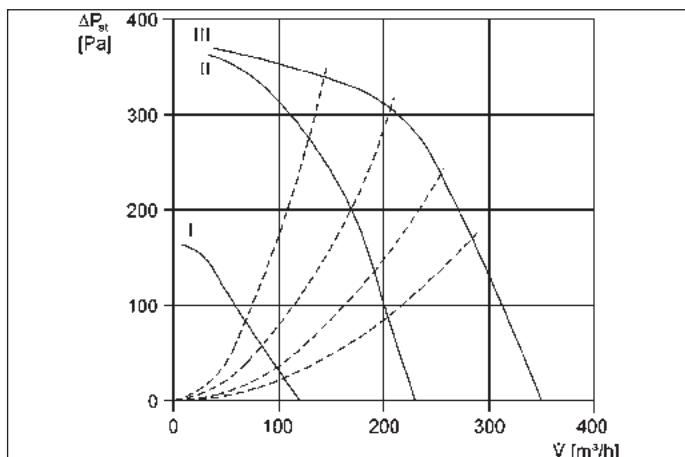
Dimensions [mm]

Characteristic curve

Important accessories
Room air control

P. 103

Control unit for WS 150, ZEG 2000 P and ER 100 D centralised ventilation units, as well as HDR EC duct fan, On/Off, 3 steps

RLS 3

0157.0831

Accessories selection table

	ZEG 2000 P	see
Room air control	RLS 3	P. 103
MAICOTherm ventilation duct system, thermally insulated	MT	P. 152
MAICOFlex ventilation duct system, round	MF	P. 158
MAICO FFS ventilation duct system, flat	FFS	P. 164
Stainless steel cowl	LH-V2A 12 LH-V2A 15 LH-V2A 16	P. 304
Outgoing air wall connection	KW-FL 12E KW-FL 12W KW-FL 16E KW-FL 16W	P. 307
Outside air opening	ALD 10 ALD 125 ALD 125 VA ALD 160 ALD 160 VA	P. 104
Roof outlet	DF	P. 306
Roofing tile	DP	P. 306
Mounting clamp	BS	P. 306
Rain protection grille	RG	P. 306
Internal grille	ESG 10/2	P. 311
Door ventilation grille	MLK 30 white MLK 45 white	P. 105
Disk valve, synthetic material	TK 10 TK 12	P. 316
Disk valve, metal	TM 10 TM 12 TFA 10 TFA 12	P. 316 P. 317
Disk valve, stainless steel	TM-V2A 10 TM-V2A 12	P. 316
Mounting frame for TFA/TFZ	EBR-D 10 EBR-D 12	P. 318
Exhaust and supply air valve	AZV 100	P. 315
Grease filter element for exhaust air	FFE 10	P. 318
Flexible aluminium duct	AFR 125	P. 319
Tubular sound absorber	RSR 12 RSR 12/50	P. 320
Slide-in sound absorber	SDE 8 SDE 10 SDE 12	P. 321

**Room air control
RLS 3**

Article	Art. No.
RLS 3	0157.0831

- Three-step room air control for ER 100 D exhaust air fan, ZEG 2000 P exhaust air unit, WS 150 centralised ventilation unit and HDR EC duct fan.
- 3 switching steps: Base load, Normal, Full-load (rotary knob).
- With separate, 2-pole on/off switch (rocker switch).
- Both switches in joint double frame.

Features

U _{nom}	230 V
Degree of protection	IP 30
Maximum load	10 A
Material	Synthetic material
Type of installation	Recessed-mounted
Width	150 mm
Height	80 mm
Depth	32 mm

Outside air openings



Outside air opening ALD 10



- Outside air opening for draught-free, decentralised domestic ventilation.
- Linear control of the air flow.
- No electrical connection required.
- Packing unit: Internal part, dust or insect filter, wall sleeve up to 500 mm, external grille with fly screen.
- Accessories: ALDS 10 storm protection, ALDF 10 replacement filter.

Article	Art. No.
ALD 10	0152.0054

Dimensions [mm]

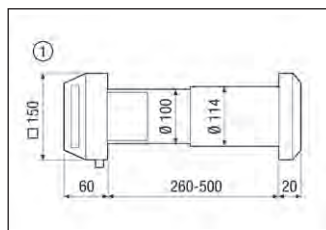

① Inside

Pressure losses

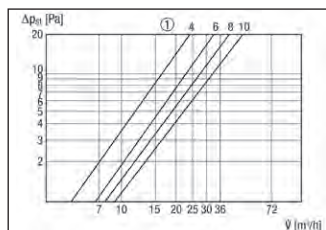

① Valve position in mm

Features

Nominal size	100 mm
Max. volumetric flow	32 m ³ /h/at 10 Pa
Filter class	G2
Material	Synthetic material
Colour	Pure white, similar to RAL 9010
Installation site	Wall
Rated max. element normal difference in noise level D _{n,w}	31 dB
Max. ambient temperature	60 °C
Air direction	Ventilation
Type of shutter	manual

Storm protection ALDS 10



- Storm protection for air flow regulation with strong or gusty winds.
- Accessories for ALD 10 outside air opening.
- Assembly by sliding into the wall sleeve.

Article	Art. No.
ALDS 10	0152.0056

Installation instructions

- In the case of detached buildings it is recommended that installation be made on the weather side and from the 3rd floor upwards.

Features

Nominal size	100 mm
Housing material	Polystyrene
Membrane material	Special silicone

Outside air openings ALD 125



- Outside air opening for draught-free, decentralised domestic ventilation.
- Type of shutter: Manual (0 % or 100 % position).
- Very good insulation.
- Flat visually appealing design.
- Good air distribution.
- No electrical connection required.
- ALD 125 packing unit: Inner part made of plastic, G2 dust filter, wall sleeve up to 500 mm with storm protection and sound insulation, manual shutter, rectangular plastic external grille including fly screen.
- ALD 125 VA packing unit: Inner part made of plastic, G2 dust filter, wall sleeve up to 500 mm with storm protection and sound insulation, manual shutter, round stainless steel external grille including fly screen.
- Accessories: ALDF 125/160 G2 or ALDF 125/160 G3 replacement filter.

Article	Art. No.	Grille material
ALD 125	0152.0067	Synthetic material
ALD 125 VA	0152.0068	Synthetic (internal grille)/ Stainless steel (external grille)

Dimensions [mm]

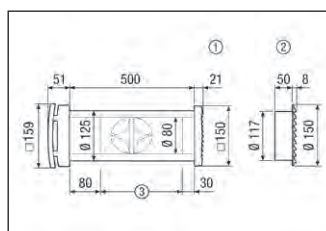

- ① Rectangular plastic external grille ALD 125
- ② Round stainless steel external grille ALD 125 VA
- ③ Shorten to wall thickness if required

Pressure losses

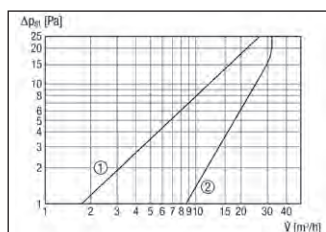

- ① Dust filter G3
- ② Dust filter G2

Common features

Nominal size	125 mm
Max. volumetric flow	30 m ³ /h
Filter class	G2
Housing material	Synthetic material
Colour	Pure white, similar to RAL 9010
Installation site	Wall
Rated max. element normal difference in noise level D _{n,w}	47 dB
Max. ambient temperature	60 °C
Air direction	Ventilation
Type of shutter	manual, can be locked

**Extension kit
ALDVS 125**



Article	Art. No.
ALDVS 125	0152.0085

- Extension kit for outside air openings ALD 125.
- Scope of delivery:
 - 500 mm long wall sleeve
 - 390 mm long sound-insulated duct

Features

Nominal size	125 mm
Housing material	Synthetic material
Installation site	Outside wall

**Outside air openings
ALD 160**



Article	Art. No.	Grille material
ALD 160	0152.0069	Synthetic material
ALD 160 VA	0152.0070	Synthetic (internal grille)/ Stainless steel (external grille)

- Outside air opening for draught-free, decentralised domestic ventilation.
- Type of shutter: Manual (0 % or 100 % position).
- Very good insulation.
- Flat visually appealing design.
- Good air distribution.
- No electrical connection required.
- ALD 160 packing unit: Inner part made of plastic, G2 dust filter, wall sleeve up to 500 mm with storm protection and sound insulation, manual shutter, rectangular plastic external grille including fly screen.
- ALD 160 VA packing unit: Inner part made of plastic, G2 dust filter, wall sleeve up to 500 mm with storm protection and sound insulation, manual shutter, round stainless steel external grille including fly screen.
- Accessories: ALDF 125/160 G2 or ALDF 125/160 G3 replacement filter.

Dimensions [mm]

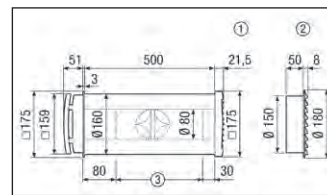

- ① Rectangular plastic external grille ALD 160
- ② Round stainless steel external grille ALD 160 VA
- ③ Shorten to wall thickness if required

Pressure losses

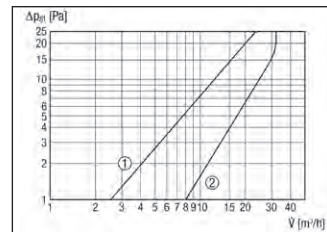

- ① Dust filter G3
- ② Dust filter G2

Common features

Nominal size	160 mm
Max. volumetric flow	30 m³/h
Filter class	G2
Housing material	Synthetic material
Colour	Pure white, similar to RAL 9010
Installation site	Wall
Rated max. element normal difference in noise level $D_{n,w}$	53 dB
Max. ambient temperature	60 °C
Air direction	Ventilation
Type of shutter	manual, can be locked

**Extension kit
ALDVS 160**



Article	Art. No.
ALDVS 160	0152.0086

- Extension kit for outside air openings ALD 160.
- Scope of delivery:
 - 500 mm long wall sleeve
 - 390 mm long sound-insulated duct

Features

Nominal size	160 mm
Housing material	Synthetic material
Installation site	Outside wall

**Door ventilation grilles
MLK**

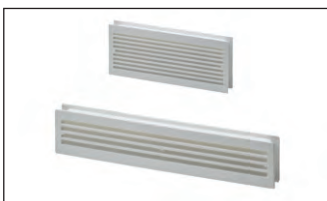

Article	Art. No.
MLK 30 white	0151.0123
MLK 45 white	0151.0126

- Door ventilation grille for bathroom, WC or kitchen.
- Free cross section in accordance with FeuVo 80 (German Heating Directives) and TRGI 86 (German Directives for Gas Installation).
- MLK 30: Door cut-out: 275 x 105 mm, external dimension: 295 x 120 mm.
- MLK 45: Door cut-out: 436 x 76 mm, external dimension: 457 x 92 mm.

Common features



Material	Synthetic material
Synthetic material definition	PVC-free polystyrene
Colour	White
Installation site	Door
Open cross section	154 cm²
Air direction	Ventilation and air extraction
Minimum door leaf thickness	30 mm

Ventilation systems with heat recovery in accordance with DIN 1946-6

Product overview

Central ventilation unit

Designed for 120 m²

		Counter cross heat exchanger	Summer bypass	Preheater	Enthalpy heat exchanger	Mobile control	
WS 150... Frost protection by shutting off the supply air fan		up to 165 m ³ /h					
		WS 150 R WS 150 L	•				
WS 160 Flat 		up to 160 m ³ /h					
		WS 160 Flat ET			•	•	
		WS 160 Flat KET			•	•	•
		WS 160 Flat BET		•	•	•	•
		WS 160 Flat KBET		•	•	•	•
* with zone ventilation WS 160 Flat KBZET*		•	•	•	•		
WS 170... 		up to 160 m ³ /h					
		WS 170...	•				
		WS 170 K...	•		•		
		WS 170 KB...	•	•	•	•	
		WS 170... ET				•	
		WS 170 K... ET			•	•	
...left-hand resp. right-hand version WS 170 KB... ET		•	•	•	•		

Designed for 250 m²

		Counter cross heat exchanger	Summer bypass	Preheater	Enthalpy heat exchanger	Mobile control
WR 310 WS 320... 		up to 320 m ³ /h				
		WR 310	•			•
		WS 320 K	•		•	•
		WS 320 B	•	•		•
		WS 320 KB	•	•	•	•
		WS 320 ET				•
		WS 320 KET			•	•
		WS 320 BET		•		•
		WS 320 KBET		•	•	•



Designed for 450 m²

		Counter cross heat exchanger	Summer bypass	Preheater	Enthalpy heat exchanger	Mobile control
WR 410 WS 470... 		up to 470 m ³ /h				
		WR 410	•			•
		WS 470 K	•		•	•
		WS 470 B	•	•		•
		WS 470 KB	•	•	•	•
		WS 470 ET				•
		WS 470 KET			•	•
		WS 470 BET		•		•
		WS 470 KBET		•	•	•

Designed for 600 m²

		Counter cross heat exchanger	Summer bypass	Preheater	Enthalpy heat exchanger	Mobile control
WR 600 Frost protection by shutting off the supply air fan		up to 600 m ³ /h				
		WR 600	•			

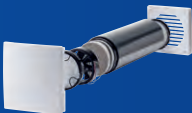
Single room ventilation unit

PushPull 45 	up to 42 m ³ /h per device	WRG 35 	up to 60 m ³ /h per device
---	---------------------------------------	---	---------------------------------------

Ventilation systems with heat recovery in accordance with DIN 1946-6

Chapter 4

Central ventilation units up to 120 m²

WS 150 up to 165 m³/h

WS 160 Flat up to 160 m³/h

WS 170 up to 160 m³/h

NEW!



Page 108
Page 112
Page 120

Central ventilation units up to 250 m²

WR 310 up to 320 m³/h

WS 320 up to 320 m³/h

NEW!



Page 128
Page 133

Central ventilation units up to 450 m²

WR 410 up to 470 m³/h

WS 470 up to 470 m³/h

NEW!



Page 128
Page 138

Central ventilation unit up to 600 m²

WR 600 up to 620 m³/h



Page 145

Room air controls / air quality controllers / radio switch



Page 148

Thermally insulated ventilation duct system MAICOTherm MT

For outside and outgoing air as well as for supply and exhaust air



Page 152

EW brine earth heat exchanger

System consisting of brine-air heat exchanger, brine pump regulator, pressure duct and other accessories



Page 156

MaicoFlex MF flexible round ventilation duct system

Air distributor for supply and exhaust air



Page 158

MAICO FFS flexible flat ventilation duct system

Air distributor for supply and exhaust air



Page 164

Single-room ventilation units

PushPull 45

Alternating operation with heat recovery, up to 42 m³/h

WRG 35

Balanced operation with heat recovery, up to 60 m³/h

NEW!



Page 168

Page 173

WS 150 centralised ventilation unit



Models

- WS 150 L: For left-hand building connections (exhaust air, supply air).
- WS 150 R: For right-hand building connections (exhaust air, supply air).
- Powder-coated plate housing in sandwich construction, with integrated heat insulation.
- Colour: light grey.
- Integrated filter system with coarse filter (G4) in the outside air and in the exhaust air. Filter change is possible without tools.

Features

- Automatic constant volumetric flow regulation for equal air quantities.
- Special energy savings due to the DC motor.
- 2 DN 125 duct connections each with rubber lip seals on side walls of unit. For directly connecting up tubular sound absorbers.

- Controlled through control unit RLS 2 F in the living room.
- Control unit for switching ventilation levels, timer and filter monitoring.
- Control unit not included in scope of delivery.
- DIBT approval.
- Connection to KNX systems possible.

Heat exchanger

- Counterflow heat exchanger made of aluminium.
- The heat exchanger can be easily removed and cleaned with water.

Energy-efficient fans

- 2 centrifugal DC fans, one fan each for supply air and exhaust air.
- 3 ventilation levels can be set:
 - 1 = Reduced ventilation: 70, 85, 95, 105 m³/h
 - 2 = Nominal ventilation: 85, 100, 120, 135 m³/h
 - 3 = Intensive ventilation: 120, 135, 150, 165 m³/h
 - Factory setting: 70/100/135 m³/h.

Mounting instructions

- Mounting on the wall or a pedestal is required to ensure access to the condensation connection.
- The front plate can be hinged open after loosening the 2 quick-release clips.
- Decouple the housing with impact sound plates for sound insulation.

Condensation drain

- Condensation is drained out at the bottom of the unit. Condensation drainage (3/4" external thread) for connection to a 1/2" hose.

Frost protection

- Frost protection by switching off the supply air fans.
- The frost protection feature switches the supply air fan off when the heat exchanger starts to freeze up.
- Recommendation: Combine heat recovery units with a brine earth heat exchanger.

Technical data

Article	Art. No.	Max. degree of heat provision in accordance with DIN EN 13141-7 (A7)	U _{nom}	f _{nom}	Con-nection dia-meter	Air flow volume	Power consumption in accordance with DIN EN 13141-7 (A7)	Stand-by power consumption	I _{max}	Housing emission sound pressure level	Filter class	Degree of protection	SPI value in accordance with DIN EN 13141-7 (A7)	Weight
		%	V	Hz	mm	m ³ /h	W		A	dB(A)		IP	Wh/m ³	kg
WS 150 L	0095.0058	90	230	50/60	125	70 - 165	27	< 2 W	0.5	31 ¹⁾	G4	00	0.23	51
WS 150 R	0095.0057	90	230	50/60	125	70 - 165	27	< 2 W	0.5	31 ¹⁾	G4	00	0.23	51

¹⁾ Spacing 1m, sound absorption 10 m²

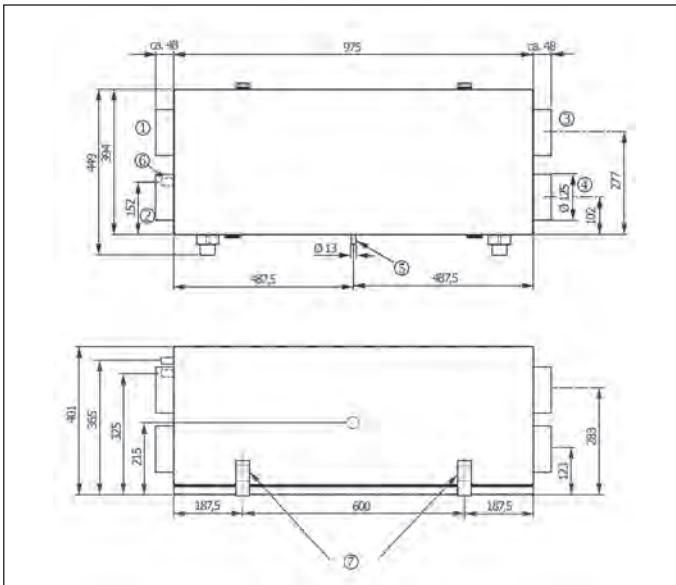

Dimensions [mm]

Connections on the left

- ① Exhaust air
- ② Supply air
- ③ Outside air
- ④ Outgoing air
- ⑤ Condensation drain
- ⑥ Electrical connections
- ⑦ Seal

Connections on the right

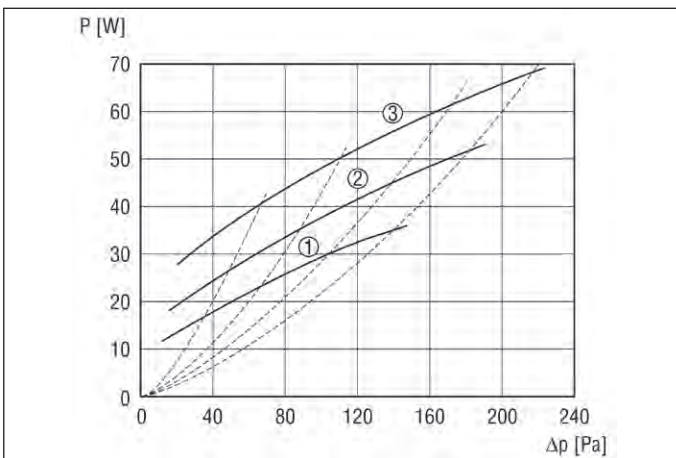
- ① Outside air
- ② Outgoing air
- ③ Exhaust air
- ④ Supply air
- ⑤ Condensation drain
- ⑥ Electrical connections
- ⑦ Seal

Characteristic curve

- ① Step 1 = 70 m³/h
- ② Step 2 = 100 m³/h
- ③ Step 3 = 135 m³/h

Important accessories
Wall bracket

P. 111

Wall bracket for mounting the WS 150 centralised ventilation unit

WSK 150 0018.0458

Dimensions [mm]

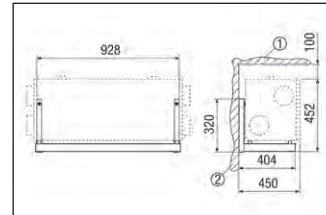

- ① Ceiling
- ② Wall

Room air control

P. 148

 Control unit for WS 150 centralised ventilation units, on/off, 3 levels, timer and time-controlled filter change display
 RLS 2 F 0157.0806

Room air control

P. 149

 Control unit for WS 150, ZEG 2000 P and ER 100 D centralised ventilation units, as well as HDR EC duct fan, On/Off, 3 steps
 RLS 3 0157.0831

Summer cassette

P. 111

Summer cassette for the supply of fresh outside air for WS 150 centralised ventilation unit

SK 150 0095.0151

Air filter, replacement
P. 111

Replacement air filter for WS 150 R and WS 150 L centralised ventilation units, filter class G4, 2 items

WSG 150 0093.0892

Hygrostats

P. 348

Hygrostat for controlling ventilation systems depending on the relative air humidity

 HY 230 0157.0126
 HY 230 I 0157.0127

WS 150 centralised ventilation unit
Sound power level in octave range

	63 Hz	125 Hz	250 Hz	500 Hz	1 kHz	2 kHz	4 kHz	8 kHz	Total
L_{LWA2} Level 2 [dB (A)]	26	28	26	28	22	19	9	5	33
L_{LWA5} Level 2 [dB (A)]	18	24	22	28	28	21	11	5	33
L_{LWA6} Level 2 [dB (A)]	19	22	24	28	28	25	10	5	33

L_{LWA5} , L_{LWA6} = sound power level emitted to the free surroundings.
 L_{LWA5} Exhaust air connections, L_{LWA6} Supply air connections.
 L_{LWA2} = housing sound power level in dB.
 L_{LWA5} = free inlet sound power level in dB.
 L_{LWA6} = free outlet sound power level in dB.

Accessories selection table

	WS 150 L	WS 150 R	see
Plug connector for duct	SVR 125	SVR 125	P. 111
45° elbow, drawn	B45-125	B45-125	P. 111
90° elbow, drawn	B90-125	B90-125	P. 111
Wall bracket	WSK 150	WSK 150	P. 111
Summer cassette	SK 150	SK 150	P. 111
Air filter, replacement	WSG 150	WSG 150	P. 111
Room air control	RLS 2 F RLS 3	RLS 2 F RLS 3	P. 148
MAICOTherm ventilation duct system, thermally insulated	MT	MT	P. 152
MAICOFlex ventilation duct system, round	MF	MF	P. 158
MAICO FFS ventilation duct system, flat	FFS	FFS	P. 164
Brine earth heat exchanger	EW	EW	P. 156
Shutter	AP 120	AP 120	P. 296
External grille	SG 120	SG 120	P. 303
Fly screen	FG 120	FG 120	P. 296
Stainless steel cowl	LH-V2A 12	LH-V2A 12	P. 304
Outside air wall connection	KW-AL 12E, KW-AL 12W, KW-AL 16E, KW-AL 16W	KW-AL 12E, KW-AL 12W, KW-AL 16E, KW-AL 16W	P. 154
Outgoing air wall connection	KW-FL 12E, KW-FL 12W, KW-FL 16E, KW-FL 16W	KW-FL 12E, KW-FL 12W, KW-FL 16E, KW-FL 16W	P. 155
Combi-wall connections	KWH 12 L, KWH 12 R, KWH 16 L, KWH 16 R	KWH 12 L, KWH 12 R, KWH 16 L, KWH 16 R	P. 155
Roof outlet	DF 125 T, DF 125 S	DF 125 T, DF 125 S	P. 306
Roofing tile	DP 125 TB, DP 125 SB, DP 125 A	DP 125 TB, DP 125 SB, DP 125 A	P. 306
Mounting clamp	BS 125	BS 125	P. 306
Rain protection grille	RG 125	RG 125	P. 306
Door ventilation grille	MLK 30 white, MLK 45 white	MLK 30 white, MLK 45 white	P. 312
Disk valve, synthetic material	TK 10, TK 12	TK 10, TK 12	P. 316
Disk valve, stainless steel	TM-V2A 10, TM-V2A 12	TM-V2A 10, TM-V2A 12	P. 316
Disk valve, metal	TM 10, TM 12, TFA 10, TFA 12, TFZ 10, TFZ 12	TM 10, TM 12, TFA 10, TFA 12, TFZ 10, TFZ 12	P. 316, P. 317
Mounting frame for TFA/TFZ	EBR-D 10, EBR-D 12	EBR-D 10, EBR-D 12	P. 318
Blower nozzle	WD 10 W, WD 10 D	WD 10 W, WD 10 D	P. 318, P. 319
Supply air valve	ZWVQ 10, ZWVQ 12	ZWVQ 10, ZWVQ 12	P. 319
Exhaust and supply air valve	AZV 100	AZV 100	P. 315
Grease filter element for exhaust air	FFE 10	FFE 10	P. 318
Sound absorber box	SB 12/16	SB 12/16	P. 320
Tubular sound absorber	RSR 12 RSR 12/50	RSR 12 RSR 12/50	P. 320
Slide-in sound absorber	SDE 8, SDE 10, SDE 12	SDE 8, SDE 10, SDE 12	P. 321
Electrical air heater	ERH 12-1	ERH 12-1	P. 323
Water air heater	WRH 12-1	WRH 12-1	P. 325
Air filter	TFE 12-4, TFE 12-5, TFE 12-7	TFE 12-4, TFE 12-5, TFE 12-7	P. 327, P. 328
Radio switch	XS 1	XS 1	P. 350
Radio receiver	XE 1	XE 1	P. 350
Thermostat	TH 10	TH 10	P. 344
Temperature control system	ETL 16 P	ETL 16 P	P. 346
Channel sensor	FL 30 P	FL 30 P	P. 346
Room sensor	FR 30 P	FR 30 P	P. 347
Air flow monitor	LW 9	LW 9	P. 347
Hygrostat	HY 230 HY 230 I	HY 230 HY 230 I	P. 348
Air quality controller	EAQ 10/1	EAQ 10/1	P. 349

**Plug connector for duct
SVR 125**

Article	Art. No.
SVR 125	0055.0183

- Plug connector for folded spiral-seam ducts, including lip seals.
- E.g. for connecting the WS 150, WS 160 Flat or WS 170 centralised ventilation units to folded spiral-seam ducts.

Features

Nominal size	125 mm
Material	Sheet steel
Max. ambient temperature	60 °C

**45° elbow, drawn
B45-125**

Article	Art. No.
B45-125	0055.0326

- 45° elbow, drawn, incl. lip seals. For folded spiral-seam ducts.
- E.g. for connecting WS 150, WS 160 Flat or WS 170 centralised ventilation units to folded spiral-seams ducts as alternative to SVR 125 plug connector.

Features

Nominal size	125 mm
Material	Sheet steel
Max. ambient temperature	60 °C

**90° elbow, drawn
B90-125**

Article	Art. No.
B90-125	0055.0312

- 90° elbow, drawn, incl. lip seals. For folded spiral-seam ducts.
- E.g. for connecting WS 150, WS 160 Flat or WS 170 centralised ventilation units to folded spiral-seams ducts as alternative to SVR 125 plug connector.

Features

Nominal size	125 mm
Material	Sheet steel
Max. ambient temperature	60 °C

**Wall bracket
WSK 150**



- Wall brackets for mounting the WS 150 ventilation unit.

Dimensions [mm]

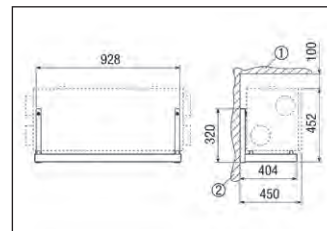

- ① Ceiling
- ② Wall

Features

Material	Sheet steel, powder coated
Colour	Black
Installation site	Wall

Article	Art. No.
WSK 150	0018.0458

**Summer cassette
SK 150**

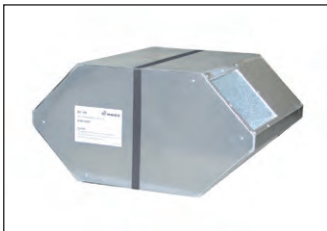

- Summer cassette for the supply of fresh outside air without using the heat exchange process during summer operation for WS 150 ventilation unit.
- Existing heat exchanger should be replaced with summer cassette.

Features

Material	Aluminium
Width	455 mm
Height	350 mm
Depth	230 mm

Article	Art. No.
SK 150	0095.0151

**Air filter, replacement
WSG**

Article	Art. No.
WSG 150	0093.0892

- Replacement air filter for WS 150 centralised ventilation unit.

Features

Filter class	G4
Width	350 mm
Height	250 mm
Depth	22 mm
Packing unit	2 x G4

WS 160 Flat centralised ventilation unit



Features

- Centralised ventilation unit with heat recovery for comfort ventilation.
- The WS 160 Flat... range of units is characterised by its compact and very flat design. The total height of just 23 cm makes space-saving installation possible in suspended ceilings.
- The highly efficient enthalpy heat exchanger fitted as standard means there is no need for a condensate drain. The installer is therefore free to select the unit's position on any ceiling, wall or inclined surface. Other benefits of the enthalpy heat exchanger with intelligent humidity control include humidity recovery and the ideal room climate, even in winter.
- The housing consists of expanded polypropylene (EPP) with thermal and sound insulation. The housing's EPP cover is covered with sheet steel for enhanced sound insulation.
- Colour black/white aluminium
- The flat units are very quiet, energy-efficient and hold an A-rating label in accordance with the ErP Directive. The fans with constant volumetric flow cover a volumetric flow range of 40 to 160 m³/h.
- The two supply air connections (fitted as standard) allow the supply air lines to be configured without crossing one another. There is therefore no need for unit variants in left-hand and right-hand versions.
- As standard, the unit has an F7 filter in the outside air and a G4 filter in the exhaust air. As an option, a G4 filter can also be retrofitted in the outside air. This filter cascade greatly extends the service life of the F7 filter.
- The controller is able to control a large number of external components, such as brine pump, external room heating or shutter for air/earth heat exchanger, and to extend the scope of the ventilation concept.
- DIBT approval applied for.
- PH certification.
- KBZET** variant: The use of the motorised zone shutter and needs-based zone regulation allows the supply air rooms to be split into 2 zones. The relevant splitting of the volumetric flows over the 2 zones can be stored in the time programme or regulated by corresponding air quality sensors in the zones.
- BET, KBET, KBZET** variants: The integrated bypass shutter (100 % bypass) with needs-based bypass control makes a continuously variable bypass control possible. Depending on temperature differences and user settings the room air can be cooled in an optimum manner without draughts.
- KET, KBET, KBZET** variants: The performance-controlled electrical preheating register is regulated depending on various parameters

recorded in the unit. The result is an efficient and energy-saving regulation strategy. Ventilation with a heat register therefore does not compromise on comfort even at low outside air temperatures.

RLS 1 WR control unit

- Included in the scope of delivery.
- Switching the 4 ventilation levels, maintenance display, fault messages.
- Other control units can be connected in parallel.
- Auto Sensor automatic operating mode.

Touch screen control unit RLS T1 WS

- Optional.
- Up to 6 operating modes possible.
- 2 automatic operating modes (Auto Sensor / Auto Time).
- 4 manual operating modes (ECO exhaust air / ECO supply air / MANUAL / OFF).

air@home

- The units have an integrated web server and can be controlled with an app when at home or out and about, e.g. using a smartphone.
- Live reports, user administration, control and setting using web tool, via tablet, laptop and PC.
- Setting options:
 - Needs-based automatic mode / Time-controlled automatic mode.
 - Manual operation / OFF.
 - ECO mode supply air or ECO mode exhaust air.
 - Filter queries, error messages.
- Registration needed. For more info, see "www.air-home.de"

Controller

- 3 temperature sensors in outside -, outgoing and supply air connections.
- 1 combination sensor (temperature and humidity) in exhaust air connection.
- Integrated excess humidity avoidance function.
- Continuously variable needs-based adaptation of air volumes.
- Multi-function contact for controlling EW brine earth heat exchanger (uncontrolled pump),

operating and fault display, preheating and postheating register, shutters.

- Can be extended with other PCBs.

ModBus

- Integrated MODBUS interface enables integration in the building control technology.

EnOcean

- Optional EnOcean plug-in module E-SM for integrating the ventilation unit into "EnOcean world" "www.enocean-alliance.org".

KNX

- Optional KNX plug-in module K-SM allows for connection to building control technology, "www.knx.org".

Heat exchanger

- Washable anti-microbial enthalpy heat exchanger made from plastic (PS).

Energy-efficient fans

- 2 radial direct current fans, curved to the front in the outside air / outgoing air.
- 4 ventilation levels can be adjusted continuously between 40.. 160 m³/h.

Mounting information

- Easy, very time-saving installation.
- Housing cover is easy to remove using guide pin and safety screw.
- Provide sound absorbers on the inlet and outlet sides.

Electrical connection

- Ready for service.
- Prepared for assembly-friendly connection of sensors.
- Extendible, functional electronics box allows optional additional circuit boards (ZP 1 and ZP 2) to be fitted with ease.

Condensation drain

- Not required.

Frost protection

- Prevents the heat exchanger from freezing up at low temperatures.
- For "K" unit models, using integrated, demand-controlled, electrical PTC preheating register.
- For "non-K" unit models, by switching off the supply air fan.



Energy efficiency class

Technical data

Article	Art. No.	Max. degree of heat provision in accordance with DIN EN 13141-7 (A7) %	U _{nom} V	f _{nom} Hz	Con- nection dia- meter mm	Air flow volume m ³ /h	Power con- sumption in accordance with DIN EN 13141-7 (A7) W	Stand-by power con- sumption	I _{max} A	Housing emission sound pressure level dB(A)	Humidity condi- tions with enthalpy heat exchanger in accordance with DIN EN 13141-7 (A2) %	Filter class	Degree of pro- tection IP	SPI value in accord- ance with DIN EN 13141-7 (A7) Wh/m ³	Weight kg
WS 160 Flat ET	0095.0090	76	230	50/60	125/160	40 - 160	36	< 1 W	1.1	37 ¹⁾	53	G4/F7	00	0.32	27
WS 160 Flat BET	0095.0092	76	230	50/60	125/160	40 - 160	36	< 1 W	1.1	37 ¹⁾	53	G4/F7	00	0.32	27
WS 160 Flat KET	0095.0091	76	230	50/60	125/160	40 - 160	36	< 1 W	4.6	37 ¹⁾	53	G4/F7	00	0.32	27
WS 160 Flat KBET	0095.0093	76	230	50/60	125/160	40 - 160	36	< 1 W	4.6	37 ¹⁾	53	G4/F7	00	0.32	27
WS 160 Flat KBZET	0095.0094	76	230	50/60	125/160	40 - 160	36	< 1 W	4.6	37 ¹⁾	53	G4/F7	00	0.32	27

¹⁾ Spacing 1m, sound absorption 10 m²
Equipment

Article	Bypass	Pre- heater	Zone shutter	Enthalpy heat ex- changer	Anti- freeze circuit	Summer circuit	Filter monitoring	Humid- ity control	CO ₂ - control (op- tional)	Air quality control (optional)	MODBUS interface	KNX con- nection (optional)	Control unit included in scope of delivery	Control unit (optional)	EnOcean wireless inte- gration (optional)	Mo- bile con- trol
WS 160 Flat ET	No	No	No	yes	yes	ECO exhaust air / ECO supply air	time-con- trolled (con- trolled by differential pressure as option)	inte- grated	SKD	EAQ 10/3	integrated	K-SM	RLS 1 WR, App	RLS T1 WS	E-SM	yes
WS 160 Flat BET	yes	No	No	yes	yes	ECO exhaust air / ECO supply air	time-con- trolled (con- trolled by differential pressure as option)	inte- grated	SKD	EAQ 10/3	integrated	K-SM	RLS 1 WR, App	RLS T1 WS	E-SM	yes
WS 160 Flat KET	No	integrated	No	yes	yes	ECO exhaust air / ECO supply air	time-con- trolled (con- trolled by differential pressure as option)	inte- grated	SKD	EAQ 10/3	integrated	K-SM	RLS 1 WR, App	RLS T1 WS	E-SM	yes
WS 160 Flat KBET	yes	integrated	No	yes	yes	ECO exhaust air / ECO supply air	time-con- trolled (con- trolled by differential pressure as option)	inte- grated	SKD	EAQ 10/3	integrated	K-SM	RLS 1 WR, App	RLS T1 WS	E-SM	yes
WS 160 Flat KBZET	yes	integrated	yes	yes	yes	ECO exhaust air / ECO supply air	time-con- trolled (con- trolled by differential pressure as option)	inte- grated	SKD	EAQ 10/3	integrated	K-SM	RLS 1 WR, App	RLS T1 WS	E-SM	yes

WS 160 Flat centralised ventilation unit



Dimensions [mm]

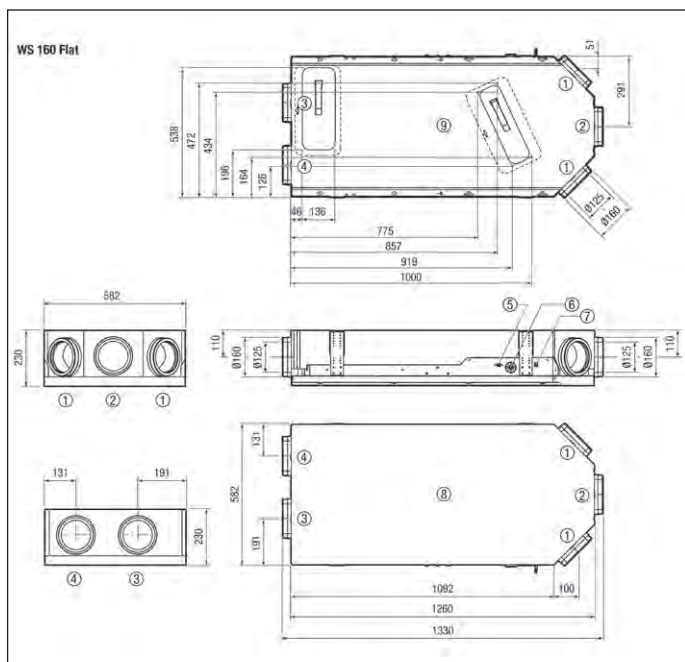

- ① DN 125 / DN 160 supply air
- ② DN 125 / DN 160 exhaust air
- ③ DN 125 / DN 160 outside air
- ④ DN 125 / DN 160 outgoing air
- ⑤ USB connection
- ⑥ Cable feedthrough
- ⑦ Electric connections
- ⑧ View from above
- ⑨ View from below

Characteristic curve

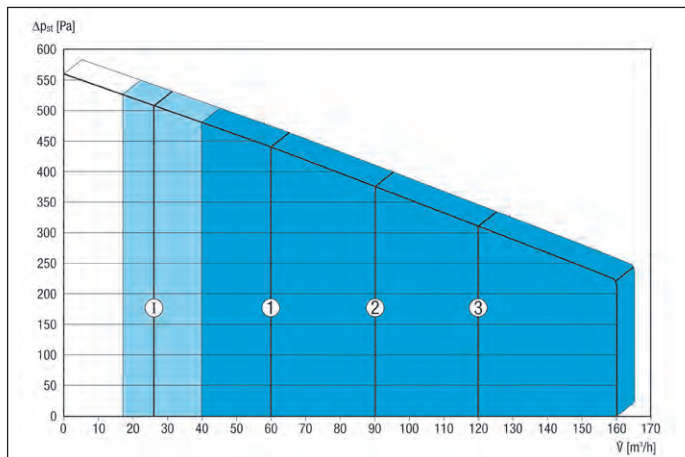

The figures shown indicate the preset ventilation levels ("factory settings").
 1 = 60 m³/h, reduced ventilation (RV)
 2 = 90 m³/h, nominal ventilation (NV)
 3 = 120 m³/h, intensive ventilation (IV)
 I = Interval or "humidity protection operation" depending on RV

Individual settings available:
 RV = 40 m³/h - 160 m³/h
 NV = 40 m³/h - 160 m³/h
 IV = 40 m³/h - 160 m³/h

Essential condition: RV < NV < IV !

Important accessories

Plug connector for duct



P. 117

Plug connector incl. lip seal, DN 125, for connecting folded spiral-seam ducts to the WS 150, WS 160 Flat or WS 170 central ventilation units

SVR 125 0055.0183

45° elbow, drawn



P. 117

45° elbow, drawn incl. lip seal, DN 125, for connecting folded spiral-seam ducts to the WS 150, WS 160 Flat or WS 170 central ventilation units

B45-125 0055.0326

90° elbow, drawn



P. 117

90° elbow, drawn incl. lip seal, DN 125, for connecting folded spiral-seam ducts to the WS 150, WS 160 Flat or WS 170 central ventilation units. Alternative to the SVR 125 plug connector

B90-125 0055.0312

Universal fixing bracket



P. 117

Fixing bracket for the assembly of WS 160 Flat centralised ventilation units on the wall or ceiling

WS-BWU 160 0092.0567

Ceiling fixing bracket



P. 118

Fixing bracket with damping element for the assembly of WS 160 Flat centralised ventilation units on the ceiling

WS-BWD 160 0092.0566

Filter locking cover



P. 118

Filter locking covers for WS 160 Flat centralised ventilation units

WS-FVA 160 0092.0565

Room air control



P. 148

Optional touch control unit for WS 160 Flat, WS 170 KBR.../ WS 170 KBL..., WR 310/WR 410, WS 320 and WS 470 centralised ventilation units. Setting time programs, operating modes, ventilation levels, temperatures etc. with integrated NTC room temperature sensor, mini USB port and 4-wire bus connection

RLS T1 WS 0157.0835

Air filters, replacement

P. 119

Replacement air filter for WS 160 Flat or WS 170 centralised ventilation units

WSF 170 0093.0271
 WSF-AKF 170 0093.0272
 WSG 170 0093.0270

Push-in frame for air filter

P. 119

Push-in frame for WSG 170 air filter, 1 item

WSG-ES 170 0093.0269

Preheating register



P. 118

Electric PTC preheating register for continuous operation of the WS 160 Flat centralised ventilation units at very low outside temperatures

WS-VH 160 0092.0568

Important accessories
Bypass for heat exchanger

P. 118

Automatic 100 % bypass with position feedback for the WS 160 Flat centralised ventilation units

WS-BP 160 0092.0569

EnOcean plug-in module

P. 151

The E-SM communication module allows the ventilation unit to be controlled with the EnOcean wireless standard. Once the plug-in module has been fitted on the basic PCB, appropriate wireless sensors / wireless control units (see EnOcean EEP list) can be taught in on the control. For WS 160 Flat, WS 170 KBR../WS 170 KBL..., WR 310/WR 410, WS 320 and WS 470 centralised ventilation units

E-SM 0092.0556

KNX plug-in module

P. 151

The K-SM is fitted on the basic PCB. This module then allows the unit control to be integrated in a KNX system (e.g. building control technology). For WS 160 Flat, WS 170 KBR../WS 170 KBL..., WR 310/WR 410, WS 320 and WS 470 centralised ventilation units

K-SM 0092.0557

Additional circuit board

P. 151

Additional circuit board for WS 160 Flat, WS 170 KBR../WS 170 KBL..., WR 310/WR 410, WS 320 and WS 470 centralised ventilation units. For example, to control an external postheating register or a controlled pump for brine earth heat exchangers

ZP 1 0092.0554

Additional circuit board

P. 151

Additional circuit board for WS 160 Flat, WS 170 KBR../WS 170 KBL..., WR 310/WR 410, WS 320 and WS 470 centralised ventilation units. For example, for operating the fans with pressure consistency or for differential pressure-controlled filter monitoring

ZP 2 0092.0555

CO₂ sensor

P. 349

Sensor for measuring the carbon dioxide concentration in the air, CO₂ measurement range from 500- 2,000 ppm, 0 - 10 V output

SKD 0157.0345

Sound power level in octave range

	63 Hz	125 Hz	250 Hz	500 Hz	1 kHz	2 kHz	4 kHz	8 kHz	Total
L _{LWA2} [dB (A)]	-	24	31	34	36	29	18	6	45
L _{LWA5} [dB (A)]	39	42	44	40	31	17	10	3	52
L _{LWA6} [dB (A)]	39	42	43	40	39	20	15	4	53

L_{LWA5}, L_{LWA6} = sound power level emitted to the free surroundings.

Measured at a subsequent operating point on the connections facing the room.

L_{LWA5} Exhaust air connections, L_{LWA6} Supply air connections.

Operating point: Reference volumetric flow 112 m³/h and external pressure 50 Pa

L_{LWA2} = housing sound power level in dB.

L_{LWA5} = free inlet sound power level in dB.

L_{LWA6} = free outlet sound power level in dB.

Accessories selection table

	WS 160 Flat ET	WS 160 Flat BET	WS 160 Flat KET	WS 160 Flat KBET	WS 160 Flat KBZET	see
Plug connector for duct	SVR 125	SVR 125	SVR 125	SVR 125	SVR 125	P. 117
45° elbow, drawn	B45-125	B45-125	B45-125	B45-125	B45-125	P. 117
90° elbow, drawn	B90-125	B90-125	B90-125	B90-125	B90-125	P. 117
Universal fixing bracket	WS-BWU 160	WS-BWU 160	WS-BWU 160	WS-BWU 160	WS-BWU 160	P. 117
Ceiling fixing bracket	WS-BWD 160	WS-BWD 160	WS-BWD 160	WS-BWD 160	WS-BWD 160	P. 118
Preheating register	WS-VH 160	WS-VH 160	-	-	-	P. 118
Bypass for heat exchanger	WS-BP 160	-	WS-BP 160	-	-	P. 118
Air filter, replacement	WSF 170 WSF-AKF 170 WSG 170	WSF 170 WSF-AKF 170 WSG 170	WSF 170 WSF-AKF 170 WSG 170	WSF 170 WSF-AKF 170 WSG 170	WSF 170 WSF-AKF 170 WSG 170	P. 119
Push-in frame for air filter	WSG-ES 170	WSG-ES 170	WSG-ES 170	WSG-ES 170	WSG-ES 170	P. 119
Filter locking cover	WS-FVA 160	WS-FVA 160	WS-FVA 160	WS-FVA 160	WS-FVA 160	P. 118
Room air control	RLS 1 WR RLS T1 WS	RLS 1 WR RLS T1 WS	RLS 1 WR RLS T1 WS	RLS 1 WR RLS T1 WS	RLS 1 WR RLS T1 WS	P. 148
EnOcean plug-in module	E-SM	E-SM	E-SM	E-SM	E-SM	P. 151
KNX plug-in module	K-SM	K-SM	K-SM	K-SM	K-SM	P. 151
Additional circuit board	ZP 1 ZP 2	ZP 1 ZP 2	ZP 1 ZP 2	ZP 1 ZP 2	ZP 1 ZP 2	P. 151
Radio switch	DS RC	DS RC	DS RC	DS RC	DS RC	P. 149
MAICOTherm ventilation duct system, thermally insulated	MT	MT	MT	MT	MT	P. 152
MAICOFlex ventilation duct system, round	MF	MF	MF	MF	MF	P. 158
MAICO FFS ventilation duct system, flat	FFS	FFS	FFS	FFS	FFS	P. 164

WS 160 Flat centralised ventilation unit

	WS 160 Flat ET	WS 160 Flat BET	WS 160 Flat KET	WS 160 Flat KBET	WS 160 Flat KBZET	see
Brine earth heat exchanger	EW	EW	EW	EW	EW	P. 156
External grille	MGR 80/125 alu	MGR 80/125 alu	MGR 80/125 alu	MGR 80/125 alu	MGR 80/125 alu	P. 304
Stainless steel cowl	LH-V2A 12	LH-V2A 12	LH-V2A 12	LH-V2A 12	LH-V2A 12	P. 304
Outside air wall connection	KW-AL 12E KW-AL 12W KW-AL 16E KW-AL 16W	KW-AL 12E KW-AL 12W KW-AL 16E KW-AL 16W	KW-AL 12E KW-AL 12W KW-AL 16E KW-AL 16W	KW-AL 12E KW-AL 12W KW-AL 16E KW-AL 16W	KW-AL 12E KW-AL 12W KW-AL 16E KW-AL 16W	P. 154
Outgoing air wall connection	KW-FL 12E KW-FL 12W KW-FL 16E KW-FL 16W	KW-FL 12E KW-FL 12W KW-FL 16E KW-FL 16W	KW-FL 12E KW-FL 12W KW-FL 16E KW-FL 16W	KW-FL 12E KW-FL 12W KW-FL 16E KW-FL 16W	KW-FL 12E KW-FL 12W KW-FL 16E KW-FL 16W	P. 155
Combi-wall connections	KWH 12 L, KWH 12 R KWH 16 L, KWH 16 R	KWH 12 L, KWH 12 R KWH 16 L, KWH 16 R	KWH 12 L, KWH 12 R KWH 16 L, KWH 16 R	KWH 12 L, KWH 12 R KWH 16 L, KWH 16 R	KWH 12 L, KWH 12 R KWH 16 L, KWH 16 R	P. 155
Roof outlet	DF 125 T, DF 125 S	DF 125 T, DF 125 S	DF 125 T, DF 125 S	DF 125 T, DF 125 S	DF 125 T, DF 125 S	P. 306
Roofing tile	DP 125 TB DP 125 SB DP 125 A	DP 125 TB DP 125 SB DP 125 A	DP 125 TB DP 125 SB DP 125 A	DP 125 TB DP 125 SB DP 125 A	DP 125 TB DP 125 SB DP 125 A	P. 306
Mounting clamp	BS 125	BS 125	BS 125	BS 125	BS 125	P. 306
Rain protection grille	RG 125	RG 125	RG 125	RG 125	RG 125	P. 306
Door ventilation grille	MLK 30 white MLK 45 white	MLK 30 white MLK 45 white	MLK 30 white MLK 45 white	MLK 30 white MLK 45 white	MLK 30 white MLK 45 white	P. 312
Disk valve, synthetic material	TK 10, TK 12	TK 10, TK 12	TK 10, TK 12	TK 10, TK 12	TK 10, TK 12	P. 316
Disk valve, stainless steel	TM-V2A 10 TM-V2A 12	TM-V2A 10 TM-V2A 12	TM-V2A 10 TM-V2A 12	TM-V2A 10 TM-V2A 12	TM-V2A 10 TM-V2A 12	P. 316
Disk valve, metal	TM 10, TM 12 TFA 10, TFA 12 TFZ 10, TFZ 12	TM 10, TM 12 TFA 10, TFA 12 TFZ 10, TFZ 12	TM 10, TM 12 TFA 10, TFA 12 TFZ 10, TFZ 12	TM 10, TM 12 TFA 10, TFA 12 TFZ 10, TFZ 12	TM 10, TM 12 TFA 10, TFA 12 TFZ 10, TFZ 12	P. 316, P. 317
Mounting frame for TFA/TFZ	EBR-D 10 EBR-D 12	EBR-D 10 EBR-D 12	EBR-D 10 EBR-D 12	EBR-D 10 EBR-D 12	EBR-D 10 EBR-D 12	P. 318
Blower nozzle	WD 10 W WD 10 D	WD 10 W WD 10 D	WD 10 W WD 10 D	WD 10 W WD 10 D	WD 10 W WD 10 D	P. 318, P. 319
Supply air valve	ZWWQ 10 ZWWQ 12	ZWWQ 10 ZWWQ 12	ZWWQ 10 ZWWQ 12	ZWWQ 10 ZWWQ 12	ZWWQ 10 ZWWQ 12	P. 319
Exhaust and supply air valve	AZV 100	AZV 100	AZV 100	AZV 100	AZV 100	P. 315
Grease filter element for exhaust air	FFE 10	FFE 10	FFE 10	FFE 10	FFE 10	P. 318
Thermally insulated long pipe elbow	ABLS 160	ABLS 160	ABLS 160	ABLS 160	ABLS 160	P. 154
Sound absorber box	SB 12/16	SB 12/16	SB 12/16	SB 12/16	SB 12/16	P. 320
Tubular sound absorber	RSR 12 RSR 16 RSR 12/50 RSR 16/50	RSR 12 RSR 16 RSR 12/50 RSR 16/50	RSR 12 RSR 16 RSR 12/50 RSR 16/50	RSR 12 RSR 16 RSR 12/50 RSR 16/50	RSR 12 RSR 16 RSR 12/50 RSR 16/50	P. 320
Flat oval duct sound absorber	RSOF 12/50 RSOF 16/50	RSOF 12/50 RSOF 16/50	RSOF 12/50 RSOF 16/50	RSOF 12/50 RSOF 16/50	RSOF 12/50 RSOF 16/50	P. 321
Slide-in sound absorber	SDE 8 SDE 10	SDE 8 SDE 10	SDE 8 SDE 10	SDE 8 SDE 10	SDE 8 SDE 10	P. 321
Electrical air heater	ERH 12-1 ERH 16-2	ERH 12-1 ERH 16-2	ERH 12-1 ERH 16-2	ERH 12-1 ERH 16-2	ERH 12-1 ERH 16-2	P. 323
Water air heater	WRH 12-1 WRH 16-2	WRH 12-1 WRH 16-2	WRH 12-1 WRH 16-2	WRH 12-1 WRH 16-2	WRH 12-1 WRH 16-2	P. 325
Air filter	TFE 12-4, TFE 16-4 TFE 12-5, TFE 16-5 TFE 12-7, TFE 16-7	TFE 12-4, TFE 16-4 TFE 12-5, TFE 16-5 TFE 12-7, TFE 16-7	TFE 12-4, TFE 16-4 TFE 12-5, TFE 16-5 TFE 12-7, TFE 16-7	TFE 12-4, TFE 16-4 TFE 12-5, TFE 16-5 TFE 12-7, TFE 16-7	TFE 12-4, TFE 16-4 TFE 12-5, TFE 16-5 TFE 12-7, TFE 16-7	P. 327, P. 328
Radio switch	XS 1	XS 1	XS 1	XS 1	XS 1	P. 350
Radio receiver	XE 1	XE 1	XE 1	XE 1	XE 1	P. 350
Thermostat	TH 10	TH 10	TH 10	TH 10	TH 10	P. 344
Temperature control system	ETL 16 P	ETL 16 P	ETL 16 P	ETL 16 P	ETL 16 P	P. 346
Channel sensor	FL 30 P	FL 30 P	FL 30 P	FL 30 P	FL 30 P	P. 346
Room sensor	FR 30 P	FR 30 P	FR 30 P	FR 30 P	FR 30 P	P. 347
Air flow monitor	LW 9	LW 9	LW 9	LW 9	LW 9	P. 347
Humidity and temperature sensor	FFT 30 K	FFT 30 K	FFT 30 K	FFT 30 K	FFT 30 K	P. 347
CO₂ sensor	SKD	SKD	SKD	SKD	SKD	P. 349
Air quality controller	EAQ 10/3	EAQ 10/3	EAQ 10/3	EAQ 10/3	EAQ 10/3	P. 150

**Plug connector for duct
SVR 125**



- Plug connector for folded spiral-seam ducts, including lip seals.
- E.g. for connecting the WS 150, WS 160 Flat or WS 170 centralised ventilation units to folded spiral-seam ducts.

Features

Nominal size	125 mm
Material	Sheet steel
Max. ambient temperature	60 °C

Article	Art. No.
SVR 125	0055.0183

**45° elbow, drawn
B45-125**



- 45° elbow, drawn, incl. lip seals. For folded spiral-seam ducts.
- E.g. for connecting WS 150, WS 160 Flat or WS 170 centralised ventilation units to folded spiral-seam ducts as alternative to SVR 125 plug connector.

Dimensions [mm]

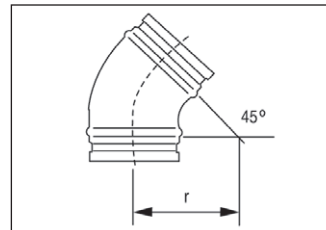

DN = R

Features

Nominal size	125 mm
Material	Sheet steel
Max. ambient temperature	60 °C

Article	Art. No.
B45-125	0055.0326

Article	DN
	mm
B45-125	125

**90° elbow, drawn
B90-125**



- 90° elbow, drawn, incl. lip seals. For folded spiral-seam ducts.
- E.g. for connecting WS 150, WS 160 Flat or WS 170 centralised ventilation units to folded spiral-seam ducts as alternative to SVR 125 plug connector.

Dimensions [mm]

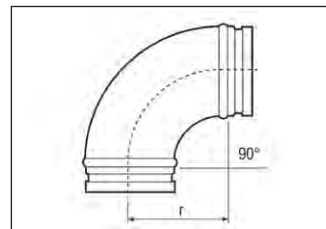

r = 125

Features

Nominal size	125 mm
Material	Sheet steel
Max. ambient temperature	60 °C

Article	Art. No.
B90-125	0055.0312

Article	DN
	mm
B90-125	125

**Universal fixing bracket
WS-BWU 160**

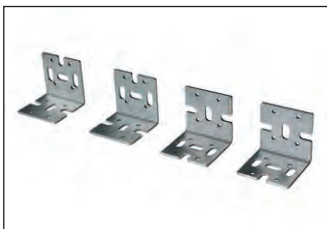

- Fixing bracket for the assembly of WS 160 Flat centralised ventilation units on the wall or ceiling.
- The bracket can be fitted in various positions on the unit to simplify fixing the unit.

Dimensions [mm]

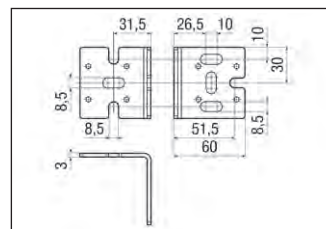

Features

Material	Sheet steel, galvanised
Installation site	Wall/Ceiling
Packing unit	4 pieces

Article	Art. No.
WS-BWU 160	0092.0567

Accessories for WS 160 Flat

Ceiling fixing bracket WS-BWD 160



- Fixing bracket for the assembly of WS 160 Flat centralised ventilation units on the ceiling.
- The unit is acoustically isolated from the ceiling by the integrated damping element.

Dimensions [mm]

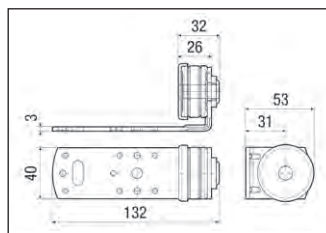

Features

Material	Sheet steel, galvanised
Installation site	Ceiling
Packing unit	4 pieces

Article	Art. No.
WS-BWD 160	0092.0566

Filter locking cover WS-FVA 160



- Filter locking cover made from powder-coated sheet for WS 160 Flat centralised ventilation units.

Dimensions [mm]

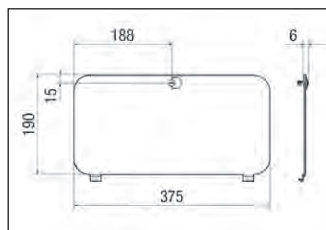

Features

Material	Sheet steel, powder coated
Packing unit	2 pieces

Article	Art. No.
WS-FVA 160	0092.0565

Preheating register WS-VH 160

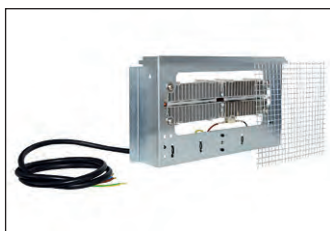

- Electric PTC preheating register for continuous operation of the WS 160 Flat centralised ventilation units at very low outside temperatures.

Features

U_{nom}	230 VAC
f_{nom}	50 Hz
Degree of protection	IP 00
Heater power rating	350 W

Article	Art. No.
WS-VH 160	0092.0568

Bypass for heat exchanger WS-BP 160



Automatic 100 % bypass with position feedback for the WS 160 Flat centralised ventilation units.

Article	Art. No.
WS-BP 160	0092.0569

Air filters, replacement WSF/WSG			
Article	Art. No.	Pack- ing unit	Filter class
WSF 170	0093.0271	1 x F7	F7
WSF-AKF 170	0093.0272	1 x active carbon, carbon M5	M5/ active carbon
WSG 170	0093.0270	10 x G4	G4

- Replacement air filters for WS 160 Flat and WS 170... centralised ventilation units.
- All WS 160 Flat and WS 170... units can be equipped in the outside air with a G4/F7 filter combination.
- Alternative to the F7 filter of the M5 active carbon filter.

Article	Width mm	Height mm	Depth mm
WSF 170	400	173	50
WSF-AKF 170	400	173	50
WSG 170	305	165	17

Push-in frame for air filter WSG-ES 170	
Article	Art. No.
WSG-ES 170	0093.0269

- Push-in frame for WSG 170 air filter.
- Can consistently be re-used.
- Is needed if the WS 160 Flat or WS 170... is to be equipped with an extra G4 filter in the outside air.

Features	
Width	300 mm
Height	165 mm
Depth	22 mm

WS 170 centralised ventilation unit



Models

- R = right-hand version, L = left-hand version
- ET = Enthalpy heat exchanger
- WS 170 R..., WS 170 L...: Standard unit with RLS 1 WR and 2 x G4 filter.
- WS 170 KR..., WS 170 KL...: Comfort unit with RLS 1 WR control, G4 filter (exhaust air) and F7 pollen filter (outside air), electric frost protection heating, sound-optimised housing.
- WS 170 KBR..., WS 170 KBL...: Bypass unit with RLS 1 WR control, G4 filter (exhaust air) and F7 pollen filter (outside air), electric frost protection heating, sound-optimised housing, bypass channel. Mobile control "air@home" using app and web tool. USB connection for service and start-up.

Features

- Compact, very quiet and energy-saving unit.
- DC motors with integrated, automatic volumetric flow regulation for constant air volume (volumetric flow consistency).
- Maximum heat recovery and time-saving adjustment.
- Maximum air tightness. Good flexibility thanks to various connection options.
- Sheet steel, powder coated housing.
- Colour white aluminium.
- Inner cladding made from temperature-resistant and extremely noise- and heat-insulating plastic (EPP). The material is also characterised by its hygienic and non-hygroscopic properties. Tested by the Institut für Luft-hygiene Berlin [Berlin Institute for Air Hygiene] according to VDI 6022 Part 1.

- The narrow unit is particularly well-suited to installation in kitchens.
- Simple filter change is possible without tools.
- 4 DN 125 duct connections. Can be equipped with plug-in connectors or duct bend (accessories).
- Connection to KNX possible.
- Connection to EnOcean possible (WS 170 KBR.../WS 170 KBL...).
- Integrated MODBUS interface (WS 170 KBR.../WS 170 KBL...).
- DIBT approval (exception WS 170..ET).
- PH certification (exception for WS 170 R.../WS 170 L... and all WS 170..ET).

RLS 1 WR control unit

- Included in scope of supply for all WS 170 devices.
- Switching the 4 ventilation levels, maintenance display, fault messages.
- Optional with/without on/off switch.
- Other control units can be connected in parallel.

RLS D1 WR digital control unit

- Optional for WS 170 R..., WS 170 L..., WS 170 KR.. and WS 170 KL...
- Control and power supply through a 2-core bus cable.
- Digital status display, switching the 4 ventilation levels, time and date (weekly program, "Plus function", maintenance display and fault messages).
- Plus function (summer operation): In the Eco operation only the exhaust fan is working; thereby approx. 50% power saving.

Touch screen control unit

RLS T1 WS

- Optional for WS 170 KBR.../WS 170 KBL...
- Up to 6 operating modes possible.
- 2 automatic operating modes (Auto Sensor / Auto Time).
- 4 manual operating modes (ECO exhaust air / ECO supply air / OFF).

air@home

- The WS 170 KBR.../WS 170 KBL... units have an integrated web server and can be controlled with an app when at home or out and about, e.g. using a smartphone.
- Live reports, user administration, control and setting using web tool, via tablet, laptop and PC.
- Settings:
 - Needs-based automatic mode / Time-controlled automatic mode.
 - Manual operation / OFF.
 - ECO mode supply air or ECO mode exhaust air.
 - Filter queries, error messages.
- Registration needed. For more info, see "www.air-home.de".

Controller

- 3 temperature sensors in outside-, outgoing and supply air connections.
- 1 combination sensor (temperature and humidity) in exhaust air connection.
- Integrated excess humidity avoidance function.
- Continuously variable needs-based adaptation of air volumes.
- Can be extended with other PCBs (z.B. ZP 1, ZP 2).

ModBus

- Units WS 170 KBR.../WS 170 KBL...
- Integrated MODBUS interface enables integration in the building control technology.

EnOcean

- Units WS 170 KBR.../WS 170 KBL...
- Optional EnOcean plug-in module E-SM for integrating the ventilation unit into "EnOcean world" "www.enocean-alliance.org".
- The data is transferred in the 868.3 MHz frequency band.
- Only the following EnOcean Equipment Profiles (EEP) are supported by the E-SM plug-in module: EEP A5-04-01, EEP A5-09-08, EEP A5-09-04, EEP F6-02-01.

KNX

- All WS 170 units can be connected to the KNX building control technology (www.knx.org).
- WS 170 R.../WS 170 L... and WS 170 KR.../WS 170 KL... via an additional KNX fan coil actuator (provided by the customer).
- WS 170 KBR.../WS 170 KBL... via optional KNX plug-in module K-SM accessory.

Heat exchanger

- Unit variants WS 170.. (Exception WS 170 ..ET): Highly efficient cross-counterflow plate heat exchanger made of plastic material (PS).
- Unit variants WS 170 ..ET: Highly efficient enthalpy cross-counterflow heat exchanger made from plastic.

Energy-efficient fans

- 2 radial direct current fans, curved to the front in the outside / outgoing air.
- 4 ventilation levels can be adjusted continuously from 40..160 m³/h. Factory settings: 60, 90, 120 m³/h.

Mounting instructions

- Easy, very time-saving mounting on the wall with the wall bracket included in the scope of delivery.
- Housing lid can be folded up using quick-release locks.
- Provide sound absorbers on the inlet and outlet sides.

Electrical connection

- Ready for service.
- Prepared for assembly-friendly connection of sensors.
- Potential-free contact e.g. for operating display.

Condensation drain

- Condensation drain (3/4" hose connection or drain pipe with a diameter of 28 mm) at the bottom of the unit.
- Connection to a siphon.
- Sturdy, easy to clean, integrated condensate tank.

Frost protection

- Prevents the heat exchanger from freezing up at low temperatures.
- Standard unit: Switching off the supply air fan.
- Comfort and bypass units: Integrated, energy-saving and self-regulating PTC heat register for preheating exhaust air.
- Recommendation: Combine units with heat recovery with a brine earth heat exchanger.



WS 170 R.../WS 170 L... and WS 170 KR.../WS 170 KL...



Energy efficiency class



PH certification: WS 170 KR.../WS 170 KL... and WS 170 KBR.../WS 170 KBL...



DIBT approval: all WS 170 devices (exception: WS 170..ET variants)



EnOcean: WS 170 KBR.../WS 170 KBL...



Mobile control: WS 170 KBR.../WS 170 KBL...

Technical data

Article	Art. No.	Max. degree of heat provision in accordance with DIN EN 13141-7 (A7)	U _{nom}	f _{nom}	Connection diameter	Air flow volume	Power consumption in accordance with DIN EN 13141-7 (A7)	Stand-by power consumption	I _{max}	Housing emission sound pressure level	Humidity conditions with enthalpy heat exchanger in accordance with DIN EN 13141-7 (A2)	Filter class	Degree of protection	SPI value in accordance with DIN EN 13141-7 (A7)	Weight
		%	V	Hz	mm	m ³ /h	W		A	dB(A)	%		IP	Wh/m ³	kg
WS 170 R	0095.0081	95	230	50/60	125	40 - 160	35	< 5 W	0.5	42/45/47 ¹⁾	–	G4/G4	00	0.32	36.5
WS 170 RET	0095.0110	90	230	50/60	125	40 - 160	36	< 5 W	0.5	42/45/47 ¹⁾	80	G4/G4	00	0.28	40
WS 170 L	0095.0082	95	230	50/60	125	40 - 160	35	< 5 W	0.5	42/45/47 ¹⁾	–	G4/G4	00	0.32	36.5
WS 170 LET	0095.0111	90	230	50/60	125	40 - 160	36	< 5 W	0.5	42/45/47 ¹⁾	80	G4/G4	00	0.28	40
WS 170 KR	0095.0083	95	230	50/60	125	40 - 160	35	< 5 W	0.5 ²⁾	32/34/35 ¹⁾	–	G4/F7	00	0.32	42.5
WS 170 KRET	0095.0112	90	230	50/60	125	40 - 160	36	< 5 W	0.5 ²⁾	32/34/35 ¹⁾	80	G4/F7	00	0.28	46
WS 170 KL	0095.0084	95	230	50/60	125	40 - 160	35	< 5 W	0.5 ²⁾	32/34/35 ¹⁾	–	G4/F7	00	0.32	42.5
WS 170 KLET	0095.0113	90	230	50/60	125	40 - 160	36	< 5 W	0.5 ²⁾	32/34/35 ¹⁾	80	G4/F7	00	0.28	46
WS 170 KBR	0095.0087	95	230	50/60	125	40 - 160	35	< 1 W	0.5 ²⁾	32/34/35 ¹⁾	–	G4/F7	00	0.32	44.8
WS 170 KBRET	0095.0114	90	230	50/60	125	40 - 160	36	< 1 W	0.5 ²⁾	32/34/35 ¹⁾	80	G4/F7	00	0.28	48
WS 170 KBL	0095.0088	95	230	50/60	125	40 - 160	35	< 1 W	0.5 ²⁾	32/34/35 ¹⁾	–	G4/F7	00	0.32	44.8
WS 170 KBLET	0095.0115	90	230	50/60	125	40 - 160	36	< 1 W	0.5 ²⁾	32/34/35 ¹⁾	80	G4/F7	00	0.28	48

¹⁾ Spacing 1m, sound absorption 10 m²
²⁾ With active 4 A frost protection heating

Equipment

Article	Bypass	Pre-heater	Enthalpy heat exchanger	Anti-freeze circuit	Summer circuit	Filter monitoring	Humidity control	CO ₂ -control (optional)	Air quality control (optional)	MODBUS interface	KNX connection (optional)	Control unit included in scope of delivery	Control unit (optional)	Wireless switch on/off (optional)	EnOcean wireless integration (optional)	Mobile control
WS 170 R	No	external	No	yes	Exhaust air with RLS D1 WR	with time control	-	SKD	EAQ 10/2	No	to be supplied by the customer	RLS 1 WR	RLS D1 WR	XE 1, XS 1	No	No
WS 170 RET	No	external	yes	yes	Exhaust air with RLS D1 WR	with time control	-	SKD	EAQ 10/2	No	to be supplied by the customer	RLS 1 WR	RLS D1 WR	XE 1, XS 1	No	No
WS 170 L	No	external	No	yes	Exhaust air with RLS D1 WR	with time control	-	SKD	EAQ 10/2	No	to be supplied by the customer	RLS 1 WR	RLS D1 WR	XE 1, XS 1	No	No
WS 170 LET	No	external	yes	yes	Exhaust air with RLS D1 WR	with time control	-	SKD	EAQ 10/2	No	to be supplied by the customer	RLS 1 WR	RLS D1 WR	XE 1, XS 1	No	No
WS 170 KR	No	integrated	No	yes	Exhaust air with RLS D1 WR	with time control	-	SKD	EAQ 10/2	No	to be supplied by the customer	RLS 1 WR	RLS D1 WR	XE 1, XS 1	No	No
WS 170 KRET	No	integrated	yes	yes	Exhaust air with RLS D1 WR	with time control	-	SKD	EAQ 10/2	No	to be supplied by the customer	RLS 1 WR	RLS D1 WR	XE 1, XS 1	No	No
WS 170 KL	No	integrated	No	yes	Exhaust air with RLS D1 WR	with time control	-	SKD	EAQ 10/2	No	to be supplied by the customer	RLS 1 WR	RLS D1 WR	XE 1, XS 1	No	No
WS 170 KLET	No	integrated	yes	yes	Exhaust air with RLS D1 WR	with time control	-	SKD	EAQ 10/2	No	to be supplied by the customer	RLS 1 WR	RLS D1 WR	XE 1, XS 1	No	No
WS 170 KBR	automatic	integrated	No	yes	Exhaust air / supply air	with time control	integrated	SKD	EAQ 10/3	integrated	K-SM	RLS 1 WR, App	RLS T1 WS	XE 1, XS 1	E-SM	yes
WS 170 KBRET	automatic	integrated	yes	yes	Exhaust air / supply air	with time control	integrated	SKD	EAQ 10/3	integrated	K-SM	RLS 1 WR, App	RLS T1 WS	XE 1, XS 1	E-SM	yes
WS 170 KBL	automatic	integrated	No	yes	Exhaust air / supply air	with time control	integrated	SKD	EAQ 10/3	integrated	K-SM	RLS 1 WR, App	RLS T1 WS	XE 1, XS 1	E-SM	yes
WS 170 KBLET	automatic	integrated	yes	yes	Exhaust air / supply air	with time control	integrated	SKD	EAQ 10/3	integrated	K-SM	RLS 1 WR, App	RLS T1 WS	XE 1, XS 1	E-SM	yes

WS 170 centralised ventilation unit



Dimensions [mm]

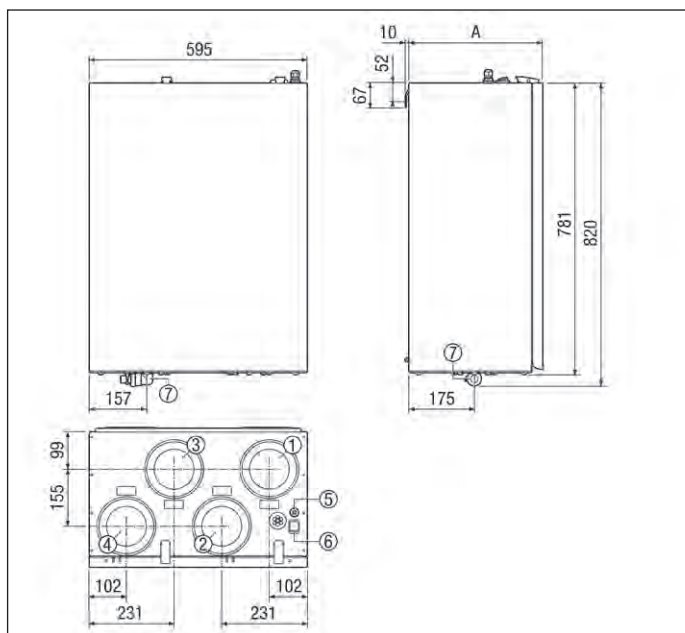

Left-hand version

- ① DN 125 outgoing air
- ② DN 125 outside air
- ③ DN 125 exhaust air
- ④ DN 125 supply air
- ⑤ Cable screw-connection
- ⑥ Main switch
- ⑦ Condensation connection

Article	A
WS 170 R	375
WS 170 RET	375
WS 170 L	375
WS 170 LET	375
WS 170 KR	375
WS 170 KRET	375
WS 170 KL	375
WS 170 KLET	375
WS 170 KBR	435
WS 170 KBRET	435
WS 170 KBL	435
WS 170 KBLET	435

Characteristic curve

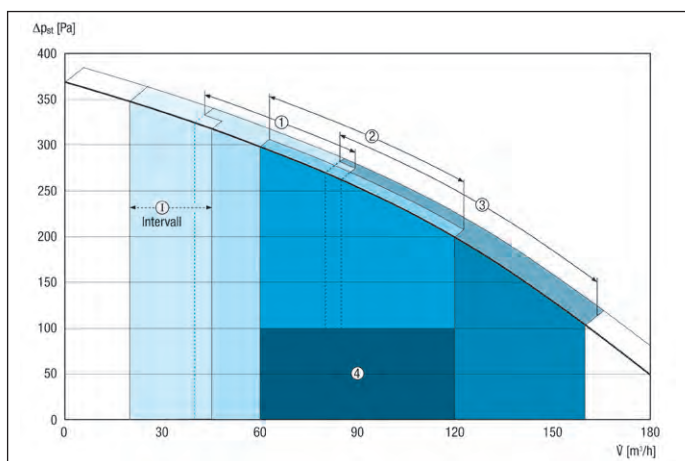

I - Interval / vacation operation for humidity protection

- ① Reduced ventilation
- ② Nominal ventilation
- ③ Intensive / Party operation
- ④ Recommended setting range

Important accessories

Plug connector for duct



P. 126

Plug connector incl. lip seal, DN 125, for connecting folded spiral-seam ducts to the WS 150, WS 160 Flat or WS 170 central ventilation units

SVR 125 0055.0183

45° elbow, drawn



P. 126

45° elbow, drawn incl. lip seal, DN 125, for connecting folded spiral-seam ducts to the WS 150, WS 160 Flat or WS 170 central ventilation units

B45-125 0055.0326

90° elbow, drawn



P. 126

90° elbow, drawn incl. lip seal, DN 125, for connecting folded spiral-seam ducts to the WS 150, WS 160 Flat or WS 170 central ventilation units. Alternative to the SVR 125 plug connector

B90-125 0055.0312

Room air control



P. 148

Optional touch control unit for WS 160 Flat, WS 170 KBR../WS 170 KBL.., WR 310/WR 410, WS 320 and WS 470 centralised ventilation units. Setting time programs, operating modes, ventilation levels, temperatures etc. with integrated NTC room temperature sensor, mini USB port and 4-wire bus connection

RLS T1 WS 0157.0835

Room air control



P. 148

Optional digital control unit for WS 170 R../WS 170 L.., WS 170 KR../WS 170 KL.. and WR 600 centralised ventilation units, with timer, filter change and fault displays and summer mode

RLS D1 WR 0157.0828

Air filters, replacement

P. 127

Replacement air filter for WS 160 Flat and WS 170.. centralised ventilation units

WSF 170 0093.0271
WSF-AKF 170 0093.0272
WSG 170 0093.0270

Push-in frame for air filter

P. 127

Push-in frame for WSG 170 air filter, 1 item

WSG-ES 170 0093.0269

Temperature sensor



P. 126

Temperature sensor with grommet for switching off the unit at a supply air temperature below 10 °C when using a warm water register

NTC 15 0157.0833

EnOcean plug-in module



P. 151

The E-SM communication module allows the ventilation unit to be controlled with the EnOcean wireless standard. Once the plug-in module has been fitted on the basic PCB, appropriate wireless sensors / wireless control units (see EnOcean EEP list) can be taught in on the control. For WS 160 Flat, WS 170 KBR../WS≈170 KBL.., WR 310/WR 410, WS 320 and WS 470 centralised ventilation units

E-SM 0092.0556

KNX plug-in module



P. 151

The K-SM is fitted on the basic PCB. This module then allows the unit control to be integrated in a KNX system (e.g. building control technology). For WS 160 Flat, WS 170 KBR../WS 170 KBL.., WR 310/WR 410, WS 320 and WS 470 centralised ventilation units

K-SM 0092.0557

Important accessories
Additional circuit board

P. 151

Additional circuit board for WS 160 Flat, WS 170 KBR../WS 170 KBL..., WR 310/WR 410, WS 320 and WS 470 centralised ventilation units. For example, to control an external postheating register or a controlled pump for brine earth heat exchangers
 ZP 1 0092.0554

Additional circuit board

P. 151

Additional circuit board for WS 160 Flat, WS 170 KBR../WS 170 KBL..., WR 310/WR 410, WS 320 and WS 470 centralised ventilation units. For example, for operating the fans with pressure consistency or for differential pressure-controlled filter monitoring
 ZP 2 0092.0555

CO₂ sensor

P. 349

Sensor for measuring the carbon dioxide concentration in the air, CO₂ measurement range from 500 - 2,000 ppm, 0 - 10 V output
 SKD 0157.0345

**Sound power level in octave range
 WS 170 R../WS 170 L..**

	63 Hz	125 Hz	250 Hz	500 Hz	1 kHz	2 kHz	4 kHz	8 kHz	Total
L_{LWA2}² Level 2 [dB (A)]	20	38	41	40	41	34	23	9	47
L_{LWA5}³ Level 2 [dB (A)]	26	36	36	36	41	32	19	4	44
L_{LWA6}³ Level 2 [dB (A)]	26	37	39	37	44	35	23	8	46

**Sound power level in octave range
 WS 170 KR../WS 170 KL..., WS 170 KBR../WS 170 KBL..**

	63 Hz	125 Hz	250 Hz	500 Hz	1 kHz	2 kHz	4 kHz	8 kHz	Total
L_{LWA2}² Level 2 [dB (A)]	27	28	29	29	28	21	15	3	36
L_{LWA5}³ Level 2 [dB (A)]	26	36	36	36	41	32	19	4	44
L_{LWA6}³ Level 2 [dB (A)]	26	37	39	37	44	35	23	8	46

L_{LWA5}¹, L_{LWA6}¹ = sound power level emitted to the free surroundings. Measured at a subsequent operating point on the connections facing the room.

L_{LWA5}² Exhaust air connections, L_{LWA6}² Supply air connections.

Operating point, level 2: Air volume 100 m³/h and external pressure 100 Pa
 In accordance with DIN 45635, Part 38, April 1986.

L_{LWA2}² = housing sound power level in dB.

L_{LWA5}³ = free inlet sound power level in dB.

L_{LWA6}³ = free outlet sound power level in dB.

L_{LWA5}¹, L_{LWA6}¹ = sound power level emitted to the free surroundings. Measured at a subsequent operating point on the connections facing the room.

L_{LWA5}² Exhaust air connections, L_{LWA6}² Supply air connections.

Operating point, level 2: Air volume 100 m³/h and external pressure 100 Pa
 In accordance with DIN 45635, Part 38, April 1986.

L_{LWA2}² = housing sound power level in dB.

L_{LWA5}³ = free inlet sound power level in dB.

L_{LWA6}³ = free outlet sound power level in dB.

WS 170 centralised ventilation unit
Accessories selection table

	WS 170 R	WS 170 RET	WS 170 L	WS 170 LET	WS 170 KR	WS 170 KRET	see
Plug connector for duct	SVR 125	SVR 125	SVR 125	SVR 125	SVR 125	SVR 125	P. 126
45° elbow, drawn	B45-125	B45-125	B45-125	B45-125	B45-125	B45-125	P. 126
90° elbow, drawn	B90-125	B90-125	B90-125	B90-125	B90-125	B90-125	P. 126
Air filter, replacement	WSF 170 WSF-AKF 170 WSG 170	WSF 170 WSF-AKF 170 WSG 170	WSF 170 WSF-AKF 170 WSG 170	WSF 170 WSF-AKF 170 WSG 170	WSF 170 WSF-AKF 170 WSG 170	WSF 170 WSF-AKF 170 WSG 170	P. 127
Push-in frame for air filter	WSG-ES 170	WSG-ES 170	WSG-ES 170	WSG-ES 170	WSG-ES 170	WSG-ES 170	P. 127
Room air control	RLS 1 WR RLS D1 WR	RLS 1 WR RLS D1 WR	RLS 1 WR RLS D1 WR	RLS 1 WR RLS D1 WR	RLS 1 WR RLS D1 WR	RLS 1 WR RLS D1 WR	P. 148
Temperature sensor	NTC 15	NTC 15	NTC 15	NTC 15	NTC 15	NTC 15	P. 126
MAICOTherm ventilation duct system, thermally insulated	MT	MT	MT	MT	MT	MT	P. 152
MAICOFlex ventilation duct system, round	MF	MF	MF	MF	MF	MF	P. 158
MAICO FFS ventilation duct system, flat	FFS	FFS	FFS	FFS	FFS	FFS	P. 164
Brine earth heat exchanger	EW	EW	EW	EW	EW	EW	P. 156
Shutter	AP 120	AP 120	AP 120	AP 120	AP 120	AP 120	P. 296
External grille	SG 120	SG 120	SG 120	SG 120	SG 120	SG 120	P. 303
Fly screen	FG 120	FG 120	FG 120	FG 120	FG 120	FG 120	P. 296
Stainless steel cowl	LH-V2A 12	LH-V2A 12	LH-V2A 12	LH-V2A 12	LH-V2A 12	LH-V2A 12	P. 304
Outside air wall connection	KW-AL 12E KW-AL 12W KW-AL 16E KW-AL 16W	KW-AL 12E KW-AL 12W KW-AL 16E KW-AL 16W	KW-AL 12E KW-AL 12W KW-AL 16E KW-AL 16W	KW-AL 12E KW-AL 12W KW-AL 16E KW-AL 16W	KW-AL 12E KW-AL 12W KW-AL 16E KW-AL 16W	KW-AL 12E KW-AL 12W KW-AL 16E KW-AL 16W	P. 154
Outgoing air wall connection	KW-FL 12E KW-FL 12W KW-FL 16E KW-FL 16W	KW-FL 12E KW-FL 12W KW-FL 16E KW-FL 16W	KW-FL 12E KW-FL 12W KW-FL 16E KW-FL 16W	KW-FL 12E KW-FL 12W KW-FL 16E KW-FL 16W	KW-FL 12E KW-FL 12W KW-FL 16E KW-FL 16W	KW-FL 12E KW-FL 12W KW-FL 16E KW-FL 16W	P. 155
Combi-wall connections	KWH 12 L KWH 12 R KWH 16 L KWH 16 R	KWH 12 L KWH 12 R KWH 16 L KWH 16 R	KWH 12 L KWH 12 R KWH 16 L KWH 16 R	KWH 12 L KWH 12 R KWH 16 L KWH 16 R	KWH 12 L KWH 12 R KWH 16 L KWH 16 R	KWH 12 L KWH 12 R KWH 16 L KWH 16 R	P. 155
Roof outlet	DF 125 T, DF 125 S	DF 125 T, DF 125 S	DF 125 T, DF 125 S	DF 125 T, DF 125 S	DF 125 T, DF 125 S	DF 125 T, DF 125 S	P. 306
Roofing tile	DP 125 TB DP 125 SB DP 125 A	DP 125 TB DP 125 SB DP 125 A	DP 125 TB DP 125 SB DP 125 A	DP 125 TB DP 125 SB DP 125 A	DP 125 TB DP 125 SB DP 125 A	DP 125 TB DP 125 SB DP 125 A	P. 306
Mounting clamp	BS 125	BS 125	BS 125	BS 125	BS 125	BS 125	P. 306
Rain protection grille	RG 125	RG 125	RG 125	RG 125	RG 125	RG 125	P. 306
Door ventilation grille	MLK 30 white MLK 45 white	MLK 30 white MLK 45 white	MLK 30 white MLK 45 white	MLK 30 white MLK 45 white	MLK 30 white MLK 45 white	MLK 30 white MLK 45 white	P. 312
Disk valve, synthetic material	TK 10, TK 12	TK 10, TK 12	TK 10, TK 12	TK 10, TK 12	TK 10, TK 12	TK 10, TK 12	P. 316
Disk valve, stainless steel	TM-V2A 10 TM-V2A 12	TM-V2A 10 TM-V2A 12	TM-V2A 10 TM-V2A 12	TM-V2A 10 TM-V2A 12	TM-V2A 10 TM-V2A 12	TM-V2A 10 TM-V2A 12	P. 316
Disk valve, metal	TM 10, TM 12 TFA 10, TFA 12 TFZ 10, TFZ 12	TM 10, TM 12 TFA 10, TFA 12 TFZ 10, TFZ 12	TM 10, TM 12 TFA 10, TFA 12 TFZ 10, TFZ 12	TM 10, TM 12 TFA 10, TFA 12 TFZ 10, TFZ 12	TM 10, TM 12 TFA 10, TFA 12 TFZ 10, TFZ 12	TM 10, TM 12 TFA 10, TFA 12 TFZ 10, TFZ 12	P.316, P. 317
Mounting frame for TFA/TFZ	EBR-D 10 EBR-D 12	EBR-D 10 EBR-D 12	EBR-D 10 EBR-D 12	EBR-D 10 EBR-D 12	EBR-D 10 EBR-D 12	EBR-D 10 EBR-D 12	P. 318
Blower nozzle	WD 10 W WD 10 D	WD 10 W WD 10 D	WD 10 W WD 10 D	WD 10 W WD 10 D	WD 10 W WD 10 D	WD 10 W WD 10 D	P. 318, P. 319
Supply air valve	ZWVQ 10 ZWVQ 12	ZWVQ 10 ZWVQ 12	ZWVQ 10 ZWVQ 12	ZWVQ 10 ZWVQ 12	ZWVQ 10 ZWVQ 12	ZWVQ 10 ZWVQ 12	P. 319
Exhaust and supply air valve	AZV 100	AZV 100	AZV 100	AZV 100	AZV 100	AZV 100	P. 315
Grease filter element for exhaust air	FFE 10	FFE 10	FFE 10	FFE 10	FFE 10	FFE 10	P. 318
Sound absorber box	SB 12/16	SB 12/16	SB 12/16	SB 12/16	SB 12/16	SB 12/16	P. 320
Tubular sound absorber	RSR 12, RSR 12/50	RSR 12, RSR 12/50	RSR 12, RSR 12/50	RSR 12, RSR 12/50	RSR 12, RSR 12/50	RSR 12, RSR 12/50	P. 320
Slide-in sound absorber	SDE 8, SDE 10 SDE 12	SDE 8, SDE 10 SDE 12	SDE 8, SDE 10 SDE 12	SDE 8, SDE 10 SDE 12	SDE 8, SDE 10 SDE 12	SDE 8, SDE 10 SDE 12	P. 321
Electrical air heater	ERH 12-1	ERH 12-1	ERH 12-1	ERH 12-1	ERH 12-1	ERH 12-1	P. 323
Water air heater	WRH 12-1	WRH 12-1	WRH 12-1	WRH 12-1	WRH 12-1	WRH 12-1	P. 325
Air filter	TFE 12-4, TFE 12-5 TFE 12-7	TFE 12-4, TFE 12-5 TFE 12-7	TFE 12-4, TFE 12-5 TFE 12-7	TFE 12-4, TFE 12-5 TFE 12-7	TFE 12-4, TFE 12-5 TFE 12-7	TFE 12-4, TFE 12-5 TFE 12-7	P. 327, P. 328
Radio switch	XS 1	XS 1	XS 1	XS 1	XS 1	XS 1	P. 350
Radio receiver	XE 1	XE 1	XE 1	XE 1	XE 1	XE 1	P. 350
Thermostat	TH 10	TH 10	TH 10	TH 10	TH 10	TH 10	P. 344
Temperature control system	ETL 16 P	ETL 16 P	ETL 16 P	ETL 16 P	ETL 16 P	ETL 16 P	P. 346
Channel sensor	FL 30 P	FL 30 P	FL 30 P	FL 30 P	FL 30 P	FL 30 P	P. 346
Room sensor	FR 30 P	FR 30 P	FR 30 P	FR 30 P	FR 30 P	FR 30 P	P. 347
Air flow monitor	LW 9	LW 9	LW 9	LW 9	LW 9	LW 9	P. 347
CO₂ sensor	SKD	SKD	SKD	SKD	SKD	SKD	P. 349
Air quality controller	EAQ 10/2	EAQ 10/2	EAQ 10/2	EAQ 10/2	EAQ 10/2	EAQ 10/2	P. 150

Accessories selection table

	WS 170 KL	WS 170 KLET	WS 170 KBR	WS 170 KBRET	WS 170 KBL	WS 170 KBLET	see
Plug connector for duct	SVR 125	SVR 125	SVR 125	SVR 125	SVR 125	SVR 125	P. 126
45° elbow, drawn	B45-125	B45-125	B45-125	B45-125	B45-125	B45-125	P. 126
90° elbow, drawn	B90-125	B90-125	B90-125	B90-125	B90-125	B90-125	P. 143
Air filter, replacement	WSF 170 WSF-AKF 170 WSG 170	WSF 170 WSF-AKF 170 WSG 170	WSF 170 WSF-AKF 170 WSG 170	WSF 170 WSF-AKF 170 WSG 170	WSF 170 WSF-AKF 170 WSG 170	WSF 170 WSF-AKF 170 WSG 170	P. 127
Push-in frame for air filter	WSG-ES 170	WSG-ES 170	WSG-ES 170	WSG-ES 170	WSG-ES 170	WSG-ES 170	P. 127
Room air control	RLS 1 WR RLS D1 WR	RLS 1 WR RLS D1 WR	RLS 1 WR RLS T1 WS	RLS 1 WR RLS T1 WS	RLS 1 WR RLS T1 WS	RLS 1 WR RLS T1 WS	P. 148
Temperature sensor	NTC 15	NTC 15	NTC 15	NTC 15	NTC 15	NTC 15	P. 126
Enocean plug-in module	–	–	E-SM	E-SM	E-SM	E-SM	P. 151
KNX plug-in module	–	–	K-SM	K-SM	K-SM	K-SM	P. 151
Additional circuit board	–	–	ZP 1, ZP 2	ZP 1, ZP 2	ZP 1, ZP 2	ZP 1, ZP 2	P. 151
Radio switch	–	–	DS RC	DS RC	DS RC	DS RC	P. 149
MAICOTherm ventilation duct system, thermally insulated	MT	MT	MT	MT	MT	MT	P. 152
MAICOFlex ventilation duct system, round	MF	MF	MF	MF	MF	MF	P. 158
MAICO FFS ventilation duct system, flat	FFS	FFS	FFS	FFS	FFS	FFS	P. 164
Brine earth heat exchanger	EW	EW	EW	EW	EW	EW	P. 156
Shutter	AP 120	AP 120	AP 120	AP 120	AP 120	AP 120	P. 296
External grille	SG 120	SG 120	SG 120	SG 120	SG 120	SG 120	P. 303
Fly screen	FG 120	FG 120	FG 120	FG 120	FG 120	FG 120	P. 296
Stainless steel cowl	LH-V2A 12	LH-V2A 12	LH-V2A 12	LH-V2A 12	LH-V2A 12	LH-V2A 12	P. 304
Outside air wall connection	KW-AL 12E KW-AL 12W KW-AL 16E KW-AL 16W	KW-AL 12E KW-AL 12W KW-AL 16E KW-AL 16W	KW-AL 12E KW-AL 12W KW-AL 16E KW-AL 16W	KW-AL 12E KW-AL 12W KW-AL 16E KW-AL 16W	KW-AL 12E KW-AL 12W KW-AL 16E KW-AL 16W	KW-AL 12E KW-AL 12W KW-AL 16E KW-AL 16W	P. 154
Outgoing air wall connection	KW-FL 12E KW-FL 12W KW-FL 16E KW-FL 16W	KW-FL 12E KW-FL 12W KW-FL 16E KW-FL 16W	KW-FL 12E KW-FL 12W KW-FL 16E KW-FL 16W	KW-FL 12E KW-FL 12W KW-FL 16E KW-FL 16W	KW-FL 12E KW-FL 12W KW-FL 16E KW-FL 16W	KW-FL 12E KW-FL 12W KW-FL 16E KW-FL 16W	P. 155
Combi-wall connections	KWH 12 L KWH 12 R KWH 16 L KWH 16 R	KWH 12 L KWH 12 R KWH 16 L KWH 16 R	KWH 12 L KWH 12 R KWH 16 L KWH 16 R	KWH 12 L KWH 12 R KWH 16 L KWH 16 R	KWH 12 L KWH 12 R KWH 16 L KWH 16 R	KWH 12 L KWH 12 R KWH 16 L KWH 16 R	P. 155
Roof outlet	DF 125 T, DF 125 S	DF 125 T, DF 125 S	DF 125 T, DF 125 S	DF 125 T, DF 125 S	DF 125 T, DF 125 S	DF 125 T, DF 125 S	P. 306
Roofing tile	DP 125 TB DP 125 SB DP 125 A	DP 125 TB DP 125 SB DP 125 A	DP 125 TB DP 125 SB DP 125 A	DP 125 TB DP 125 SB DP 125 A	DP 125 TB DP 125 SB DP 125 A	DP 125 TB DP 125 SB DP 125 A	P. 306
Mounting clamp	BS 125	BS 125	BS 125	BS 125	BS 125	BS 125	P. 306
Rain protection grille	RG 125	RG 125	RG 125	RG 125	RG 125	RG 125	P. 306
Door ventilation grille	MLK 30 white MLK 45 white	MLK 30 white MLK 45 white	MLK 30 white MLK 45 white	MLK 30 white MLK 45 white	MLK 30 white MLK 45 white	MLK 30 white MLK 45 white	P. 312
Disk valve, synthetic material	TK 10, TK 12	TK 10, TK 12	TK 10, TK 12	TK 10, TK 12	TK 10, TK 12	TK 10, TK 12	P. 316
Disk valve, stainless steel	TM-V2A 10 TM-V2A 12	TM-V2A 10 TM-V2A 12	TM-V2A 10 TM-V2A 12	TM-V2A 10 TM-V2A 12	TM-V2A 10 TM-V2A 12	TM-V2A 10 TM-V2A 12	P. 316
Disk valve, metal	TM 10, TM 12 TFA 10, TFA 12 TFZ 10, TFZ 12	TM 10, TM 12 TFA 10, TFA 12 TFZ 10, TFZ 12	TM 10, TM 12 TFA 10, TFA 12 TFZ 10, TFZ 12	TM 10, TM 12 TFA 10, TFA 12 TFZ 10, TFZ 12	TM 10, TM 12 TFA 10, TFA 12 TFZ 10, TFZ 12	TM 10, TM 12 TFA 10, TFA 12 TFZ 10, TFZ 12	P.316, P.317
Mounting frame for TFA/TFZ	EBR-D 10, EBR-D 12	EBR-D 10, EBR-D 12	EBR-D 10, EBR-D 12	EBR-D 10, EBR-D 12	EBR-D 10, EBR-D 12	EBR-D 10, EBR-D 12	P. 318
Blower nozzle	WD 10 W WD 10 D	WD 10 W, WD 10 D	WD 10 W, WD 10 D	WD 10 W, WD 10 D	WD 10 W, WD 10 D	WD 10 W, WD 10 D	P. 318, P. 319
Supply air valve	ZWVQ 10, ZWVQ 12	ZWVQ 10, ZWVQ 12	ZWVQ 10, ZWVQ 12	ZWVQ 10, ZWVQ 12	ZWVQ 10, ZWVQ 12	ZWVQ 10, ZWVQ 12	P. 319
Exhaust and supply air valve	AZV 100	AZV 100	AZV 100	AZV 100	AZV 100	AZV 100	P. 315
Grease filter element for exhaust air	FFE 10	FFE 10	FFE 10	FFE 10	FFE 10	FFE 10	P. 318
Sound absorber box	SB 12/16	SB 12/16	SB 12/16	SB 12/16	SB 12/16	SB 12/16	P. 320
Tubular sound absorber	RSR 12 RSR 12/50	RSR 12 RSR 12/50	RSR 12 RSR 12/50	RSR 12 RSR 12/50	RSR 12 RSR 12/50	RSR 12 RSR 12/50	P. 320
Slide-in sound absorber	SDE 8, SDE 10 SDE 12	SDE 8, SDE 10 SDE 12	SDE 8, SDE 10 SDE 12	SDE 8, SDE 10 SDE 12	SDE 8, SDE 10 SDE 12	SDE 8, SDE 10 SDE 12	P. 321
Electrical air heater	ERH 12-1	ERH 12-1	ERH 12-1	ERH 12-1	ERH 12-1	ERH 12-1	P. 323
Water air heater	WRH 12-1	WRH 12-1	WRH 12-1	WRH 12-1	WRH 12-1	WRH 12-1	P. 325
Air filter	TFE 12-4, TFE 12-5 TFE 12-7	TFE 12-4, TFE 12-5 TFE 12-7	TFE 12-4, TFE 12-5 TFE 12-7	TFE 12-4, TFE 12-5 TFE 12-7	TFE 12-4, TFE 12-5 TFE 12-7	TFE 12-4, TFE 12-5 TFE 12-7	P. 327, P. 328
Radio switch	XS 1	XS 1	XS 1	XS 1	XS 1	XS 1	P. 350
Radio receiver	XE 1	XE 1	XE 1	XE 1	XE 1	XE 1	P. 350
Thermostat	TH 10	TH 10	TH 10	TH 10	TH 10	TH 10	P. 344
Temperature control system	ETL 16 P	ETL 16 P	ETL 16 P	ETL 16 P	ETL 16 P	ETL 16 P	P. 346
Channel sensor	FL 30 P	FL 30 P	FL 30 P	FL 30 P	FL 30 P	FL 30 P	P. 346
Room sensor	FR 30 P	FR 30 P	FR 30 P	FR 30 P	FR 30 P	FR 30 P	P. 347
Air flow monitor	LW 9	LW 9	LW 9	LW 9	LW 9	LW 9	P. 347
CO₂ sensor	SKD	SKD	SKD	SKD	SKD	SKD	P. 349
Air quality controller	EAQ 10/2	EAQ 10/2	EAQ 10/3	EAQ 10/3	EAQ 10/3	EAQ 10/3	P. 150

Accessories for WS 170

Plug connector for duct SVR 125



- Plug connector for folded spiral-seam ducts, including lip seals.
- E.g. for connecting the WS 150, WS 160 Flat or WS 170 centralised ventilation units to folded spiral-seam ducts.

Article	Art. No.
SVR 125	0055.0183

Features

Nominal size	125 mm
Material	Sheet steel
Max. ambient temperature	60 °C

45° elbow, drawn B45-125



- 45° elbow, drawn, incl. lip seals. For folded spiral-seam ducts.
- E.g. for connecting WS 150, WS 160 Flat or WS 170 centralised ventilation units to folded spiral-seam ducts as alternative to SVR 125 plug connector.

Article	Art. No.
B45-125	0055.0326

Dimensions [mm]

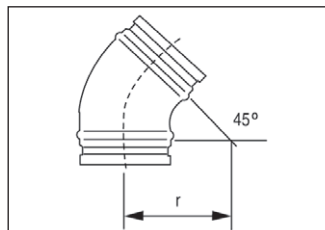

DN = R

Article	DN mm
B45-125	125

Features

Nominal size	125 mm
Material	Sheet steel
Max. ambient temperature	60 °C

90° elbow, drawn B90-125



- 90° elbow, drawn, incl. lip seals. For folded spiral-seam ducts.
- E.g. for connecting WS 150, WS 160 Flat or WS 170 centralised ventilation units to folded spiral-seam ducts as alternative to SVR 125 plug connector.

Article	Art. No.
B90-125	0055.0312

Dimensions [mm]

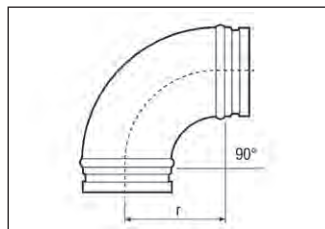

r = 125

Article	DN mm
B90-125	125

Features

Nominal size	125 mm
Material	Sheet steel
Max. ambient temperature	60 °C

Temperature sensor NTC 15



- Temperature sensor with grommet for switching off the unit at a supply air temperature below 10 °C when using a warm water register.
- This is claimed by the Passivhausinstitut for the protection of an ideal warm water register, e.g. WRH 12-1, in the supply air.
- Accessories for ventilation unit with heat recovery WS 170.

Article	Art. No.
NTC 15	0157.0833

Air filters, replacement WSF/WSG			
Article	Art. No.	Pack- ing unit	Filter class
WSF 170	0093.0271	1 x F7	F7
WSF-AKF 170	0093.0272	1 x active carbon, carbon M5	M5/ active carbon
WSG 170	0093.0270	10 x G4	G4

- Replacement air filters for WS 160 Flat and WS 170... centralised ventilation units.
- All WS 160 Flat and WS 170... units can be equipped in the outside air with a G4/F7 filter combination.
- Alternative to the F7 filter of the M5 active carbon filter.

Article	Width mm	Height mm	Depth mm
WSF 170	400	173	50
WSF-AKF 170	400	173	50
WSG 170	305	165	17

Push-in frame for air filter WSG-ES 170	
Article	Art. No.
WSG-ES 170	0093.0269

- Push-in frame for WSG 170 air filter.
- Can consistently be re-used.
- Is needed if the WS 160 Flat or WS 170... is to be equipped with an extra G4 filter in the outside air.

Features	
Width	300 mm
Height	165 mm
Depth	22 mm

WR 310 / WR 410 centralised ventilation unit



Models

- WR 310
- WR 410

Features

- Highly efficient, intelligent, centralised ventilation unit with heat recovery for comfort ventilation.
- Compact and very quiet unit for wall / standalone mounting (optional).
- An easily accessible USB port for service/start-up characterises all unit variants.
- DC motors with integrated, automatic volumetric flow regulation for constant air volume ("volumetric flow consistency").
- The DC motors can be operated via the optional additional "pressure constant" PCB ZP 2.
- Good customer service/ease of use thanks to modern unit module technology.
- Good flexibility thanks to various equipment and connection options.
- Housing: Sheet steel, powder coated.
- Colour: white aluminium.
- Inner cladding made from temperature-resistant and extremely noise- and heat-insulating plastic (EPP). The material is also characterised by its hygienic and non-hygroscopic properties. Tested by the Institut für Luft-hygiene Berlin [Berlin Institute for Air Hygiene] according to VDI 6022 Part 1.

- Additional noise-insulating cladding in the supply air guide.
- Maximum air tightness.
- Simple filter change is possible without tools.
- 4 DN 160 duct connections.
- Can be equipped with plug-in connectors or duct bend (accessories).
- The WR 310 and WR 410 unit variants can be upgraded later on (e.g. electr. PTC preheating register (optional) or bypass (optional) or enthalpy heat exchanger (optional)).
- DIBT approval.
- PH certification.

RLS 1 WR control unit

- Included in the scope of delivery.**
- Switching the 4 ventilation levels, maintenance display, fault messages.
- Other control units can be connected in parallel.

Touch screen control unit RLS T1 WS

- Optional.**
- Up to 6 operating modes possible.
- 2 automatic operating modes (Auto Sensor / Auto Time).
- 4 manual operating modes (ECO exhaust air / ECO supply air / MANUAL / OFF).

air@home

- The units have an integrated web server and can be controlled with an app when at home or out and about, e.g. using a smartphone.
- Live reports, user administration, control and setting using web tool, via tablet, laptop and PC.
- Settings:
 - Needs-based automatic mode / Time-controlled automatic mode.
 - Manual operation / OFF.
 - ECO mode supply air or ECO mode exhaust air.
 - Filter queries, error messages.
- Registration needed. For more info, see "www.air-home.de".

Controller

- 3 temperature sensors in outside -, outgoing and supply air connections.
- 1 combination sensor (temperature and humidity) in exhaust air connection.
- Integrated excess humidity avoidance function.
- Continuously variable needs-based adaptation of air volumes.
- Multi-function contact for controlling EW brine earth heat exchanger (uncontrolled pump), operating and fault display, preheating and postheating register, shutters.
- Can be extended with other PCBs (e.g. ZP 1, ZP 2).

ModBus

- Integrated MODBUS interface enables integration in the building control technology.

EnOcean

- Optional EnOcean plug-in module E-SM for integrating the ventilation unit into "EnOcean world" "www.enocean-alliance.org".

KNX

- Optional KNX plug-in module K-SM allows for connection to building control technology, "www.knx.org".

Heat exchanger

- Highly efficient cross-counterflow plate heat exchanger made of plastic material (PS).

Energy-efficient fans

- 2 radial direct current fans, curved to the front in the supply air / outgoing air.
- 4 ventilation levels can be adjusted continuously between 80.. 320 m³/h (WR 310) / 80.. 470 m³/h (WR 410).

Mounting instructions

- Easy, very time-saving mounting with the wall bracket included in the scope of delivery.
- Housing cover is easy to remove using practical magnetic locks.
- Provide sound absorbers on the inlet and outlet sides.

Electrical connection

- Ready for service with on/off switch.
- Prepared for assembly-friendly connection of sensors.
- Extendible, functional electronics box allows optional additional circuit boards (ZP 1 and ZP 2) to be fitted with ease.

Condensation drain

- Condensation drain (1 1/2" screen valve).
- Connection to an optional siphon (DN40).
- Easy-clean condensate tank integrated in EPP housing.

Frost protection

- Prevents the heat exchanger from freezing up at low temperatures.
- By switching off the supply air fan.
- Recommendation: Combine units with heat recovery with a brine earth heat exchanger.



Energy efficiency class for WR 310



Energy efficiency class for WR 410

Technical data

Article	Art. No.	Max. degree of heat provision in accordance with DIN EN 13141-7 (A7) %	U _{nom} V	f _{nom} Hz	Con- nection diameter mm	Air flow volume m ³ /h	Power con- sumption in accordance with DIN EN 13141-7 (A7) W	Stand-by power con- sump- tion	I _{max} A	Housing emission sound pressure level dB(A)	Filter class	Degree of pro- tection IP	SPI value in accordance with DIN EN 13141-7 (A7) Wh/m ³	Weight kg
WR 310	0095.0220	96	230	50/60	160	80 - 320	37	< 1 W	1.5	36 ¹⁾	G4/F7	40	0.18	67
WR 410	0095.0228	96	230	50/60	160	80 - 470	87	< 1 W	2	42 ¹⁾	G4/F7	40	0.26	67

¹⁾ Spacing 1m, sound absorption 10 m²

Equipment

Article	Bypass	Pre- heater	Enthalpy heat ex- changer	Anti- freeze circuit	Summer circuit	Filter monit- oring	Humidity control	CO ₂ - control (op- tional)	Air quality control (op- tional)	MODBUS interface	KNX con- nection (optional)	Control unit included in scope of delivery	Control unit (op- tional)	EnOcean wireless integration (optional)	Mobile control
WR 310	No	No	No	yes	ECO exhaust air / ECO supply air	with time control	integrated	SKD	EAQ 10/3	integrated	K-SM	RLS 1 WR, App	RLS T1 WS	E-SM	yes
WR 410	No	No	No	yes	ECO exhaust air / ECO supply air	with time control	integrated	SKD	EAQ 10/3	integrated	K-SM	RLS 1 WR, App	RLS T1 WS	E-SM	yes

Important accessories
Plug connector for duct

P. 143

Plug connector incl. lip seal, DN 160, for connecting folded spiral-seams ducts to the WR 310/WR 410, WS 320 and WS 470 central ventilation units
SVR 160 0055.0185

90° elbow, drawn

P. 143

90° elbow, drawn, incl. lip seal, DN 160, for connecting folded spiral-seams ducts to the WR 310/WR 410, WS 320 and WS 470 central ventilation units. Alternative to the SVR 160 plug connector
B90-160 0055.0314

Assembly feet

P. 143

Assembly feet for upright installation of WR 310/WR 410, WS 320 and WS 470 centralised ventilation units
WS-MF 320/470 0092.0558

Siphon

P. 144

1 1/2" siphon for screen valve connection for the WR 310/WR 410, WS 320 and WS 470 centralised ventilation units
WS-SI 320/470 0092.0564

Room air control

P. 148

Optional touch control unit for WS 160 Flat, WS 170 KBR../WS 170 KBL..., WR 310/WR 410, WS 320 and WS 470 centralised ventilation units. Setting time programs, operating modes, ventilation levels, temperatures etc. with integrated NTC room temperature sensor, mini USB port and 4-wire bus connection
RLS T1 WS 0157.0835

Air filters, replacement
P. 144

Replacement air filter for WR 310/WR 410, WS 320 and WS 470 centralised ventilation units
WSF-AKF 320/470 0092.0563
WSF 320/470 0092.0559
WSG 320/470 0092.0560

Replacement filter mat
P. 144

Replacement filter mats for WR 310/WR 410, WS 320 and WS 470 centralised ventilation units, filter class G4, 10 items
WSG-EG 320/470 0092.0562

Push-in frame for air filter

P. 144

Push-in frame for WSG 320/470 air filter, 1 item
WSG-ES 320/470 0092.0561

Preheating register

P. 143

Electric PTC preheating register for continuous operation of the WR 310/WR 410, WS 320 and WS 470 centralised ventilation units at very low outside temperatures
WS-VH 320/470 0093.1266

Bypass for heat exchanger

P. 144

Automatic 100% bypass with position feedback for WR 310/WR 410, WS 320 and WS 470 centralised ventilation units
WS-BP 320/470 0093.1265

EnOcean plug-in module

P. 151

The E-SM communication module allows the ventilation unit to be controlled with the EnOcean wireless standard. Once the plug-in module has been fitted on the basic PCB, appropriate wireless sensors / wireless control units (see EnOcean EEP list) can be taught in on the control.
For WS 160 Flat, WS 170 KBR../WS 170 KBL..., WR 310/WR 410, WS 320 and WS 470 centralised ventilation units
E-SM 0092.0556

KNX plug-in module

P. 151

The K-SM is fitted on the basic PCB. This module then allows the unit control to be integrated in a KNX system (e.g. building control technology).
For WS 160 Flat, WS 170 KBR../WS 170 KBL..., WR 310/WR 410, WS 320 and WS 470 centralised ventilation units
K-SM 0092.0557

Additional circuit board

P. 151

Additional circuit board for WS 160 Flat, WS 170 KBR../WS 170 KBL..., WR 310/WR 410, WS 320 and WS 470 centralised ventilation units. For example, to control an external postheating register or a controlled pump for brine earth heat exchangers
ZP 1 0092.0554

Additional circuit board

P. 151

Additional circuit board for WS 160 Flat, WS 170 KBR../WS 170 KBL..., WR 310/WR 410, WS 320 and WS 470 centralised ventilation units. For example, for operating the fans with pressure consistency or for differential pressure-controlled filter monitoring
ZP 2 0092.0555

CO₂ sensor

P. 349

Sensor for measuring the carbon dioxide concentration in the air, CO₂ measurement range from 500 - 2,000 ppm, 0 - 10 V output
SKD 0157.0345

WR 310 / WR 410 centralised ventilation unit

Sound power level in octave range WR 310

	63 Hz	125 Hz	250 Hz	500 Hz	1 kHz	2 kHz	4 kHz	8 kHz	Total
L_{LWA2} [dB (A)]	19	29	39	40	38	30	20	20	44
L_{LWA5} [dB (A)]	35	35	34	33	37	28	15	15	42
L_{LWA6} [dB (A)]	40	44	46	45	46	29	19	16	52

L_{LWA5}, L_{LWA6} = sound power level emitted to the free surroundings. Measured at a subsequent operating point on the connections facing the room.
 L_{LWA5} Exhaust air connections, L_{LWA6} Supply air connections.
 Operating point: Reference volumetric flow 210 m³/h and external pressure 50 Pa
 L_{LWA2} = housing sound power level in dB.
 L_{LWA5} = free inlet sound power level in dB.
 L_{LWA6} = free outlet sound power level in dB.

Sound power level in octave range WR 410

	63 Hz	125 Hz	250 Hz	500 Hz	1 kHz	2 kHz	4 kHz	8 kHz	Total
L_{LWA2} [dB (A)]	30	38	43	46	46	38	27	20	50
L_{LWA5} [dB (A)]	43	44	41	41	45	37	28	14	50
L_{LWA6} [dB (A)]	50	55	56	55	55	41	36	35	62

L_{LWA5}, L_{LWA6} = sound power level emitted to the free surroundings. Measured at a subsequent operating point on the connections facing the room.
 L_{LWA5} Exhaust air connections, L_{LWA6} Supply air connections.
 Operating point: Reference volumetric flow 340 m³/h and external pressure 50 Pa
 L_{LWA2} = housing sound power level in dB.
 L_{LWA5} = free inlet sound power level in dB.
 L_{LWA6} = free outlet sound power level in dB.

Accessories selection table

	WR 310	WR 410	see
Plug connector for duct	SVR 160	SVR 160	P. 143
90° elbow, drawn	B90-160	B90-160	P. 143
Assembly feet	WS-MF 320/470	WS-MF 320/470	P. 143
Siphon	WS-SI 320/470	WS-SI 320/470	P. 144
Preheating register	WS-VH 320/470	WS-VH 320/470	P. 143
Bypass for heat exchanger	WS-BP 320/470	WS-BP 320/470	P. 144
Air filter, replacement	WSF-AKF 320/470, WSF 320/470, WSG 320/470	WSF-AKF 320/470, WSF 320/470, WSG 320/470	P. 144
Replacement filter mat	WSG-EG 320/470	WSG-EG 320/470	P. 144
Push-in frame for air filter	WSG-ES 320/470	WSG-ES 320/470	P. 144
Room air control	RLS 1 WR, RLS T1 WS	RLS 1 WR, RLS T1 WS	P. 148
Enocean plug-in module	E-SM	E-SM	P. 151
KNX plug-in module	K-SM	K-SM	P. 151
Additional circuit board	ZP 1, ZP 2	ZP 1, ZP 2	P. 151
Radio switch	DS RC	DS RC	P. 149
MAICOTherm ventilation duct system, thermally insulated	MT	MT	P. 152
MAICOFlex ventilation duct system, round	MF	MF	P. 158
MAICO FFS ventilation duct system, flat	FFS	FFS	P. 164
Brine earth heat exchanger	EW	EW	P. 156
Shutter	AS 20	AS 20	P. 297
External grille	MGR 160 alu	MGR 160 alu	P. 304
Stainless steel cowl	LH-V2A 16	LH-V2A 16	P. 304
Outside air wall connection	KW-AL 16E, KW-AL 16W, KW-AL 20E, KW-AL 20W	KW-AL 16E, KW-AL 16W, KW-AL 20E, KW-AL 20W	P. 154
Outgoing air wall connection	KW-FL 16E, KW-FL 16W, KW-FL 20E, KW-FL 20W	KW-FL 16E, KW-FL 16W, KW-FL 20E, KW-FL 20W	P. 155
Combi-wall connections	KWH 16 L, KWH 16 R, KWH 20 L, KWH 20 R	KWH 16 L, KWH 16 R, KWH 20 L, KWH 20 R	P. 155
Roof outlet	DF 160 S	DF 160 S	P. 306
Roofing tile	DP 160 SB, DP 160 A	DP 160 SB, DP 160 A	P. 306
Mounting clamp	BS 160	BS 160	P. 306
Rain protection grille	RG 160	RG 160	P. 306
Door ventilation grille	MLK 30 white, MLK 45 white	MLK 30 white, MLK 45 white	P. 312
Disk valve, synthetic material	TK 10, TK 12	TK 10, TK 12	P. 316
Disk valve, stainless steel	TM-V2A 10, TM-V2A 12	TM-V2A 10, TM-V2A 12	P. 316
Disk valve, metal	TM 10, TM 12, TFA 10, TFA 12, TFZ 10, TFZ 12	TM 10, TM 12, TFA 10, TFA 12, TFZ 10, TFZ 12	P. 316, P. 317
Mounting frame for TFA/TFZ	EBR-D 10, EBR-D 12	EBR-D 10, EBR-D 12	P. 318
Blower nozzle	WD 10 W, WD 10 D	WD 10 W, WD 10 D	P. 318, P. 319
Supply air valve	ZWVQ 10, ZWVQ 12	ZWVQ 10, ZWVQ 12	P. 319
Exhaust and supply air valve	AZV 100	AZV 100	P. 315
Grease filter element for exhaust air	FFE 10	FFE 10	P. 318
Thermally insulated long pipe elbow	ABLS 160	ABLS 160	P. 154
Sound absorber box	SB 12/16	SB 12/16	P. 320
Tubular sound absorber	RSR 10, RSR 12, RSR 16, RSR 16/50	RSR 10, RSR 12, RSR 16, RSR 16/50	P. 320
Slide-in sound absorber	SDE 8, SDE 10, SDE 12	SDE 8, SDE 10, SDE 12	P. 321
Electrical air heater	ERH 16-2	ERH 16-2	P. 323
Water air heater	WRH 16-2	WRH 16-2	P. 325
Air filter	TFE 16-4, TFE 16-5, TFE 16-7	TFE 16-4, TFE 16-5, TFE 16-7	P. 327, P. 328
Radio switch	XS 1	XS 1	P. 350
Radio receiver	XE 1	XE 1	P. 350
Thermostat	TH 10	TH 10	P. 344
Temperature control system	ETL 16 P	ETL 16 P	P. 346
Channel sensor	FL 30 P	FL 30 P	P. 346
Room sensor	FR 30 P	FR 30 P	P. 347
Air flow monitor	LW 9	LW 9	P. 347
Humidity and temperature sensor	FFT 30 K	FFT 30 K	P. 347
CO₂ sensor	SKD	SKD	P. 349
Air quality controller	EAQ 10/3	EAQ 10/3	P. 150

Models

- B: With integrated, automatically controlled, 100% bypass with position feedback.
- K: With integrated, demand-controlled, electrical PTC preheating register.
- KB: With PTC preheating register and bypass.
- ET: With integrated, anti-microbial enthalpy heat exchanger for transferring humidity and heat.
- BET: With bypass and enthalpy heat exchanger.
- KET: With PTC preheating register and enthalpy heat exchanger.
- KBET: With PTC preheating register, bypass and enthalpy heat exchanger.
- Good flexibility thanks to various equipment and connection options.
- Housing: Sheet steel, powder coated.
- Colour: white aluminium.
- Inner cladding made from temperature-resistant and extremely noise- and heat-insulating plastic (EPP). The material is also characterised by its hygienic and non-hygroscopic properties. Tested by the Institut für Lufthygiene Berlin [Berlin Institute for Air Hygiene] according to VDI 6022 Part 1.
- Additional noise-insulating cladding in the supply air guide.
- Maximum air tightness.
- Simple filter change is possible without tools.
- 4 DN 160 duct connections.
- Can be equipped with plug-in connectors or duct bend (accessories).
- All unit variants (e.g. "K") can also be converted into other unit variants (e.g. "KET") later on using optional components.
- DIBT approval.
- PH certification.

Features

- Highly efficient, intelligent, centralised ventilation unit with heat recovery for comfort ventilation.
- Compact and very quiet unit for wall / standalone mounting (optional).
- An easily accessible USB port for service/start-up characterises all unit variants.
- DC motors with integrated, automatic volumetric flow regulation for constant air volume ("volumetric flow consistency").
- The DC motors can be operated via the optional additional "pressure constant" PCB ZP 2.
- Good customer service/ease of use thanks to modern unit module technology.

RLS 1 WR control unit

- **Included in the scope of delivery.**
- Switching the 4 ventilation levels, maintenance display, fault messages.
- Other control units can be connected in parallel.

Touch screen control unit
RLS T1 WS

- **Optional.**
- Up to 6 operating modes possible.
- 2 automatic operating modes (Auto Sensor / Auto Time).
- 4 manual operating modes (ECO exhaust air / ECO supply air / MANUAL / OFF).

air@home

- The units have an integrated web server and can be controlled with an app when at home or out and about, e.g. using a smartphone.
- Live reports, user administration, control and setting using web tool, via tablet, laptop and PC.
- Settings:
 - Needs-based automatic mode / Time-controlled automatic mode.
 - Manual operation / OFF.
 - ECO mode supply air or ECO mode exhaust air.
 - Filter queries, error messages.
- Registration needed. For more info, see "www.air-home.de".

Controller

- 3 temperature sensors in outside-, outgoing and supply air connections.
- 1 combination sensor (temperature and humidity) in exhaust air connection.
- Integrated excess humidity avoidance function.
- Continuously variable needs-based adaptation of air volumes.
- Multi-function contact for controlling EW brine earth heat exchanger (uncontrolled pump), operating and fault display, preheating and postheating register, shutters.
- Can be extended with other PCBs (e.g. ZP 1, ZP 2).

ModBus

- Integrated MODBUS interface enables integration in the building control technology.

EnOcean

- Optional EnOcean plug-in module E-SM for integrating the ventilation unit into "EnOcean world" "www.enocean-alliance.org".

KNX

- Optional KNX plug-in module K-SM allows for connection to building control technology, "www.knx.org".

Heat exchanger

- Highly efficient cross-counter-flow plate heat exchanger made of plastic material (PS), and/or washable, anti-microbial enthalpy heat exchanger made of plastic (PS).

Energy-efficient fans

- 2 radial direct current fans, curved to the front in the supply air / outgoing air.
- 4 ventilation levels can be adjusted continuously between 80.. 320 m³/h.

Mounting instructions

- Easy, very time-saving mounting with the wall bracket included in the scope of delivery.
- Housing cover is easy to remove using practical magnetic locks.
- Provide sound absorbers on the inlet and outlet sides.

Electrical connection

- Ready for service with on/off switch.
- Prepared for assembly-friendly connection of sensors.
- Extendible, functional electronics box allows optional additional circuit boards (ZP 1 and ZP 2) to be fitted with ease.

Condensation drain

- Condensation drain (1 1/2" screen valve).
- Connection to an optional siphon (DN40).
- Easy-clean condensate tank integrated in EPP housing.

Frost protection

- Prevents the heat exchanger from freezing up at low temperatures.
- For "K" unit models, using integrated, demand-controlled, electrical PTC preheating register.
- For "non-K" unit models, by switching off the supply air fan.
- Recommendation: For "non-K" unit models, combine with heat recovery with a brine earth heat exchanger.



Energy efficiency class for WS 320 B, K, KB



Energy efficiency class for WS 320 ET, BET, KET, KBET

WS 320 centralised ventilation unit
Technical data

Article	Art. No.	Max. degree of heat provision in accordance with DIN EN 13141-7 (A7)	U _{nom}	f _{nom}	Con- nec- tion dia- meter	Air flow volume	Power con- sumption in accordance with DIN EN 13141-7 (A7)	Stand-by power consump- tion	I _{max}	Housing emission sound pressure level	Humidity con- ditions with enthalpy heat exchanger in accordance with DIN EN 13141-7 (A2)	Filter class	Degree of protec- tion	SPI value in accord- ance with DIN EN 13141-7 (A7)	Weight
		%	V	Hz	mm	m ³ /h	W		A	dB(A)	%		IP	Wh/m ³	kg
WS 320 K	0095.0222	96	230	50/60	160	80 - 320	37	< 1 W	11	36 ¹⁾	–	G4/F7	40	0.18	67
WS 320 B	0095.0221	96	230	50/60	160	80 - 320	37	< 1 W	1.5	36 ¹⁾	–	G4/F7	40	0.18	67
WS 320 KB	0095.0223	96	230	50/60	160	80 - 320	37	< 1 W	11	36 ¹⁾	–	G4/F7	40	0.18	67
WS 320 ET	0095.0224	93	230	50/60	160	80 - 320	36	< 1 W	1.5	36 ¹⁾	70	G4/F7	40	0.17	73
WS 320 KET	0095.0226	93	230	50/60	160	80 - 320	36	< 1 W	11	36 ¹⁾	70	G4/F7	40	0.17	73
WS 320 BET	0095.0225	93	230	50/60	160	80 - 320	36	< 1 W	1.5	36 ¹⁾	70	G4/F7	40	0.17	73
WS 320 KBET	0095.0227	93	230	50/60	160	80 - 320	36	< 1 W	11	36 ¹⁾	70	G4/F7	40	0.17	73

¹⁾ Spacing 1m, sound absorption 10 m²

Equipment

Article	Bypass	Pre- heater	Enthalpy heat ex- changer	Anti- freeze circuit	Summer circuit	Filter moni- toring	Humid- ity control	CO ₂ - control (op- tional)	Air quality control (op- tional)	MODBUS interface	KNX con- nec- tion (op- tional)	Control unit included in scope of delivery	Control unit (op- tional)	EnOcean wireless integration (optional)	Mobile control
WS 320 K	No	inte- grated	No	yes	ECO exhaust air / ECO supply air	with time control	inte- grated	SKD	EAQ 10/3	integrated	K-SM	RLS 1 WR, App	RLS T1 WS	E-SM	yes
WS 320 B	yes	No	No	yes	ECO exhaust air / ECO supply air	with time control	inte- grated	SKD	EAQ 10/3	integrated	K-SM	RLS 1 WR, App	RLS T1 WS	E-SM	yes
WS 320 KB	yes	inte- grated	No	yes	ECO exhaust air / ECO supply air	with time control	inte- grated	SKD	EAQ 10/3	integrated	K-SM	RLS 1 WR, App	RLS T1 WS	E-SM	yes
WS 320 ET	No	No	yes	yes	ECO exhaust air / ECO supply air	with time control	inte- grated	SKD	EAQ 10/3	integrated	K-SM	RLS 1 WR, App	RLS T1 WS	E-SM	yes
WS 320 KET	No	inte- grated	yes	yes	ECO exhaust air / ECO supply air	with time control	inte- grated	SKD	EAQ 10/3	integrated	K-SM	RLS 1 WR, App	RLS T1 WS	E-SM	yes
WS 320 BET	yes	No	yes	yes	ECO exhaust air / ECO supply air	with time control	inte- grated	SKD	EAQ 10/3	integrated	K-SM	RLS 1 WR, App	RLS T1 WS	E-SM	yes
WS 320 KBET	yes	inte- grated	yes	yes	ECO exhaust air / ECO supply air	with time control	inte- grated	SKD	EAQ 10/3	integrated	K-SM	RLS 1 WR, App	RLS T1 WS	E-SM	yes

Dimensions [mm]

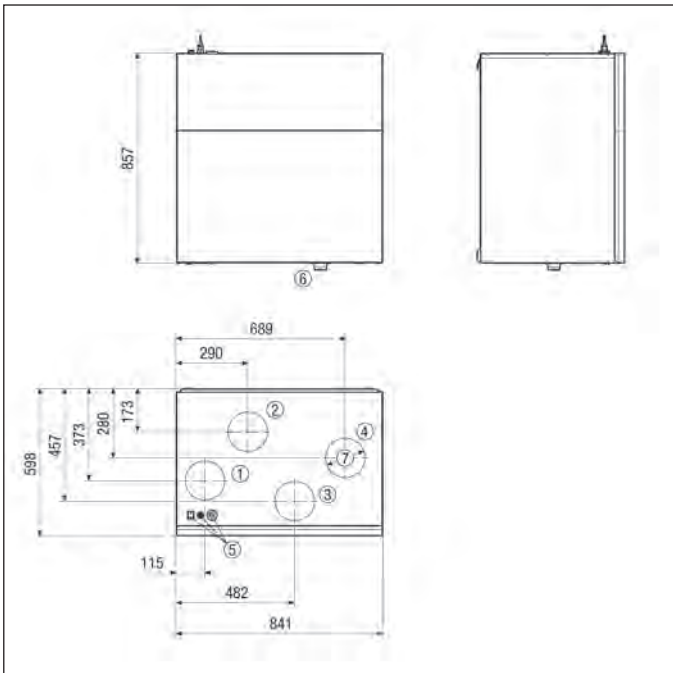

- ① DN 160 supply air
- ② DN 160 exhaust air
- ③ DN 160 outside air
- ④ DN 160 outgoing air
- ⑤ Unit switches / electric connections
- ⑥ Condensation drain
- ⑦ for DN 160 plug connector

Characteristic curve

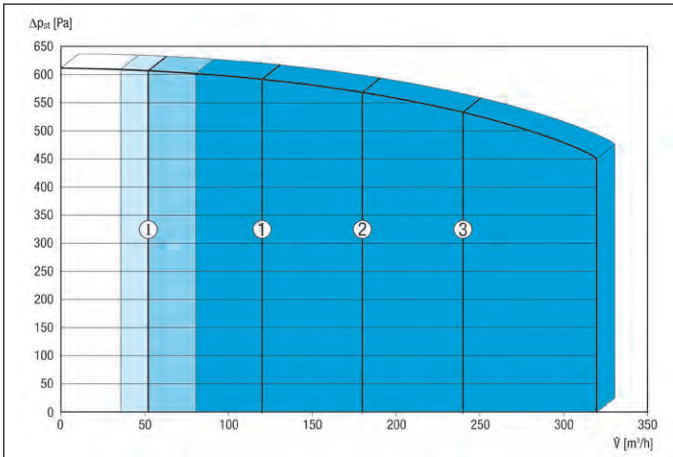

The figures shown indicate the preset ventilation levels ("factory settings").
 1 = 120 m³/h, reduced ventilation (RV)
 2 = 180 m³/h, nominal ventilation (NV)
 3 = 240 m³/h, intensive ventilation (IV)
 I = Interval or "humidity protection operation" depending on RV

Individual settings available:
 RV = 80 m³/h - 320 m³/h
 NV = 80 m³/h - 320 m³/h
 IV = 80 m³/h - 320 m³/h

Essential condition: RV < NV < IV !

Important accessories

Plug connector for duct



P. 143

Plug connector incl. lip seal, DN 160, for connecting folded spiral-seams ducts to the WR 310/WR 410, WS 320 and WS 470 central ventilation units
 SVR 160 0055.0185

90° elbow, drawn



P. 143

90° elbow, drawn, incl. lip seal, DN 160, for connecting folded spiral-seams ducts to the WR 310/WR 410, WS 320 and WS 470 central ventilation units. Alternative to the SVR 160 plug connector
 B90-160 0055.0314

Assembly feet



P. 143

Assembly feet for upright installation of WR 310/WR 410, WS 320 and WS 470 centralised ventilation units
 WS-MF 320/470 0092.0558

Siphon



P. 144

1 1/2" siphon for screen valve connection for the WR 310/WR 410, WS 320 and WS 470 centralised ventilation units
 WS-SI 320/470 0092.0564

Room air control



P. 148

Optional touch control unit for WS 160 Flat, WS 170 KBR../WS 170 KBL..., WR 310/WR 410, WS 320 and WS 470 centralised ventilation units. Setting time programs, operating modes, ventilation levels, temperatures etc. with integrated NTC room temperature sensor, mini USB port and 4-wire bus connection
 RLS T1 WS 0157.0835

Air filters, replacement

P. 144

Replacement air filter for WR 310/WR 410, WS 320 and WS 470 centralised ventilation units
 WSF-AKF 320/470 0092.0563
 WSF 320/470 0092.0559
 WSG 320/470 0092.0560

Replacement filter mat

P. 144

Replacement filter mats for WR 310/WR 410, WS 320 and WS 470 centralised ventilation units, filter class G4, 10 items
 WSG-EG 320/470 0092.0562

Push-in frame for air filter



P. 144

Push-in frame for WSG 320/470 air filter, 1 item
 WSG-ES 320/470 0092.0561

Preheating register



P. 143

Electric PTC preheating register for continuous operation of the WR 310/WR 410, WS 320 and WS 470 centralised ventilation units at very low outside temperatures
 WS-VH 320/470 0093.1266

Bypass for heat exchanger



P. 144

Automatic 100% bypass with position feedback for WR 310/WR 410, WS 320 and WS 470 centralised ventilation units
 WS-BP 320/470 0093.1265

WS 320 centralised ventilation unit

Important accessories

Enocean plug-in module



P. 151

The E-SM communication module allows the ventilation unit to be controlled with the EnOcean wireless standard. Once the plug-in module has been fitted on the basic PCB, appropriate wireless sensors / wireless control units (see Enocean EEP list) can be taught in on the control. For WS 160 Flat, WS 170 KBR../WS 170KBL..., WR 310/WR 410, WS 320 and WS 470 centralised ventilation units

E-SM 0092.0556

KNX plug-in module



P. 151

The K-SM is fitted on the basic PCB. This module then allows the unit control to be integrated in a KNX system (e.g. building control technology). For WS 160 Flat, WS 170 KBR../WS 170 KBL..., WR 310/WR 410, WS 320 and WS 470 centralised ventilation units

K-SM 0092.0557

Additional circuit board



P. 151

Additional circuit board for WS 160 Flat, WS 170 KBR../WS 170 KBL..., WR 310/WR 410, WS 320 and WS 470 centralised ventilation units. For example, to control an external postheating register or a controlled pump for brine earth heat exchangers

ZP 1 0092.0554

Additional circuit board



P. 151

Additional circuit board for WS 160 Flat, WS 170 KBR../WS 170 KBL..., WR 310/WR 410, WS 320 and WS 470 centralised ventilation units. For example, for operating the fans with pressure consistency or for differential pressure-controlled filter monitoring

ZP 2 0092.0555

CO₂ sensor



P. 349

Sensor for measuring the carbon dioxide concentration in the air, CO₂ measurement range from 500 - 2,000 ppm, 0 - 10 V output

SKD 0157.0345

Sound power level in octave range

	63 Hz	125 Hz	250 Hz	500 Hz	1 kHz	2 kHz	4 kHz	8 kHz	Total
L _{LWA2} [dB (A)]	19	29	39	40	38	30	20	20	44
L _{LWA5} [dB (A)]	35	35	34	33	37	28	15	15	42
L _{LWA6} [dB (A)]	40	44	46	45	46	29	19	16	52

L_{LWA5}, L_{LWA6} = sound power level emitted to the free surroundings.

Measured at a subsequent operating point on the connections facing the room.

L_{LWA5} Exhaust air connections, L_{LWA6} Supply air connections.

Operating point: Reference volumetric flow 210 m³/h and external pressure 50 Pa

L_{LWA2} = housing sound power level in dB.

L_{LWA5} = free inlet sound power level in dB.

L_{LWA6} = free outlet sound power level in dB.

Accessories selection table

	WS 320 K	WS 320 B	WS 320 KB	WS 320 ET	WS 320 KET	WS 320 BET	WS 320 KBET	see
Plug connector for duct	SVR 160	SVR 160	SVR 160	SVR 160	SVR 160	SVR 160	SVR 160	P. 143
90° elbow, drawn	B90-160	B90-160	B90-160	B90-160	B90-160	B90-160	B90-160	P. 143
Assembly feet	WS-MF 320/470	WS-MF 320/470	WS-MF 320/470	WS-MF 320/470	WS-MF 320/470	WS-MF 320/470	WS-MF 320/470	P. 143
Siphon	WS-SI 320/470	WS-SI 320/470	WS-SI 320/470	WS-SI 320/470	WS-SI 320/470	WS-SI 320/470	WS-SI 320/470	P. 144
Preheating register	-	WS-VH 320/470	-	WS-VH 320/470	-	WS-VH 320/470	-	P. 143
Bypass for heat exchanger	WS-BP 320/470	-	-	WS-BP 320/470	WS-BP 320/470	-	-	P. 144
Air filter, replacement	WSF-AKF 320/470 WSF 320/470 WSG 320/470	WSF-AKF 320/470 WSF 320/470 WSG 320/470	WSF-AKF 320/470 WSF 320/470 WSG 320/470	WSF-AKF 320/470 WSF 320/470 WSG 320/470	WSF-AKF 320/470 WSF 320/470 WSG 320/470	WSF-AKF 320/470 WSF 320/470 WSG 320/470	WSF-AKF 320/470 WSF 320/470 WSG 320/470	P. 144
Replacement filter mat	WSG-EG 320/470	WSG-EG 320/470	WSG-EG 320/470	WSG-EG 320/470	WSG-EG 320/470	WSG-EG 320/470	WSG-EG 320/470	P. 144
Push-in frame for air filter	WSG-ES 320/470	WSG-ES 320/470	WSG-ES 320/470	WSG-ES 320/470	WSG-ES 320/470	WSG-ES 320/470	WSG-ES 320/470	P. 144
Room air control	RLS 1 WR RLS T1 WS	RLS 1 WR RLS T1 WS	RLS 1 WR RLS T1 WS	RLS 1 WR RLS T1 WS	RLS 1 WR RLS T1 WS	RLS 1 WR RLS T1 WS	RLS 1 WR RLS T1 WS	P. 148
Enocean plug-in module	E-SM	E-SM	E-SM	E-SM	E-SM	E-SM	E-SM	P. 151
KNX plug-in module	K-SM	K-SM	K-SM	K-SM	K-SM	K-SM	K-SM	P. 151
Additional circuit board	ZP 1 ZP 2	ZP 1 ZP 2	ZP 1 ZP 2	ZP 1 ZP 2	ZP 1 ZP 2	ZP 1 ZP 2	ZP 1 ZP 2	P. 151
Radio switch	DS RC	DS RC	DS RC	DS RC	DS RC	DS RC	DS RC	P. 149
MAICOTherm ventilation duct system, thermally insulated	MT	MT	MT	MT	MT	MT	MT	P. 152
MAICOFlex ventilation duct system, round	MF	MF	MF	MF	MF	MF	MF	P. 158
MAICO FFS ventilation duct system, flat	FFS	FFS	FFS	FFS	FFS	FFS	FFS	P. 164
Brine earth heat exchanger	EW	EW	EW	EW	EW	EW	EW	P. 156

	WS 320 K	WS 320 B	WS 320 KB	WS 320 ET	WS 320 KET	WS 320 BET	WS 320 KBET	see
Shutter	AS 20	AS 20	AS 20	AS 20	AS 20	AS 20	AS 20	P. 297
External grille	MGR 160 alu	MGR 160 alu	MGR 160 alu	MGR 160 alu	MGR 160 alu	MGR 160 alu	MGR 160 alu	P. 304
Stainless steel cowl	LH-V2A 16	LH-V2A 16	LH-V2A 16	LH-V2A 16	LH-V2A 16	LH-V2A 16	LH-V2A 16	P. 304
Outside air wall connection	KW-AL 16E KW-AL 16W KW-AL 20E KW-AL 20W	KW-AL 16E KW-AL 16W KW-AL 20E KW-AL 20W	KW-AL 16E KW-AL 16W KW-AL 20E KW-AL 20W	KW-AL 16E KW-AL 16W KW-AL 20E KW-AL 20W	KW-AL 16E KW-AL 16W KW-AL 20E KW-AL 20W	KW-AL 16E KW-AL 16W KW-AL 20E KW-AL 20W	KW-AL 16E KW-AL 16W KW-AL 20E KW-AL 20W	P. 154
Outgoing air wall connection	KW-FL 16E KW-FL 16W KW-FL 20E KW-FL 20W	KW-FL 16E KW-FL 16W KW-FL 20E KW-FL 20W	KW-FL 16E KW-FL 16W KW-FL 20E KW-FL 20W	KW-FL 16E KW-FL 16W KW-FL 20E KW-FL 20W	KW-FL 16E KW-FL 16W KW-FL 20E KW-FL 20W	KW-FL 16E KW-FL 16W KW-FL 20E KW-FL 20W	KW-FL 16E KW-FL 16W KW-FL 20E KW-FL 20W	P. 155
Combi-wall connections	KWH 16 L KWH 16 R KWH 20 L KWH 20 R	KWH 16 L KWH 16 R KWH 20 L KWH 20 R	KWH 16 L KWH 16 R KWH 20 L KWH 20 R	KWH 16 L KWH 16 R KWH 20 L KWH 20 R	KWH 16 L KWH 16 R KWH 20 L KWH 20 R	KWH 16 L KWH 16 R KWH 20 L KWH 20 R	KWH 16 L KWH 16 R KWH 20 L KWH 20 R	P. 155
Roof outlet	DF 160 S	DF 160 S	DF 160 S	DF 160 S	DF 160 S	DF 160 S	DF 160 S	P. 306
Roofing tile	DP 160 SB DP 160 A	DP 160 SB DP 160 A	DP 160 SB DP 160 A	DP 160 SB DP 160 A	DP 160 SB DP 160 A	DP 160 SB DP 160 A	DP 160 SB DP 160 A	P. 306
Mounting clamp	BS 160	BS 160	BS 160	BS 160	BS 160	BS 160	BS 160	P. 306
Rain protection grille	RG 160	RG 160	RG 160	RG 160	RG 160	RG 160	RG 160	P. 306
Door ventilation grille	MLK 30 white MLK 45 white	MLK 30 white MLK 45 white	MLK 30 white MLK 45 white	MLK 30 white MLK 45 white	MLK 30 white MLK 45 white	MLK 30 white MLK 45 white	MLK 30 white MLK 45 white	P. 312
Disk valve, synthetic material	TK 10 TK 12	TK 10 TK 12	TK 10 TK 12	TK 10 TK 12	TK 10 TK 12	TK 10 TK 12	TK 10 TK 12	P. 316
Disk valve, stainless steel	TM-V2A 10 TM-V2A 12	TM-V2A 10 TM-V2A 12	TM-V2A 10 TM-V2A 12	TM-V2A 10 TM-V2A 12	TM-V2A 10 TM-V2A 12	TM-V2A 10 TM-V2A 12	TM-V2A 10 TM-V2A 12	P. 316
Disk valve, metal	TM 10 TM 12 TFA 10 TFA 12 TFZ 10 TFZ 12	TM 10 TM 12 TFA 10 TFA 12 TFZ 10 TFZ 12	TM 10 TM 12 TFA 10 TFA 12 TFZ 10 TFZ 12	TM 10 TM 12 TFA 10 TFA 12 TFZ 10 TFZ 12	TM 10 TM 12 TFA 10 TFA 12 TFZ 10 TFZ 12	TM 10 TM 12 TFA 10 TFA 12 TFZ 10 TFZ 12	TM 10 TM 12 TFA 10 TFA 12 TFZ 10 TFZ 12	P. 316, P. 317
Mounting frame for TFA/TFZ	EBR-D 10 EBR-D 12	EBR-D 10 EBR-D 12	EBR-D 10 EBR-D 12	EBR-D 10 EBR-D 12	EBR-D 10 EBR-D 12	EBR-D 10 EBR-D 12	EBR-D 10 EBR-D 12	P. 318
Blower nozzle	WD 10 W WD 10 D	WD 10 W WD 10 D	WD 10 W WD 10 D	WD 10 W WD 10 D	WD 10 W WD 10 D	WD 10 W WD 10 D	WD 10 W WD 10 D	P. 318, P. 319
Supply air valve	ZWVQ 10 ZWVQ 12	ZWVQ 10 ZWVQ 12	ZWVQ 10 ZWVQ 12	ZWVQ 10 ZWVQ 12	ZWVQ 10 ZWVQ 12	ZWVQ 10 ZWVQ 12	ZWVQ 10 ZWVQ 12	P. 319
Exhaust and supply air valve	AZV 100	AZV 100	AZV 100	AZV 100	AZV 100	AZV 100	AZV 100	P. 315
Grease filter element for exhaust air	FFE 10	FFE 10	FFE 10	FFE 10	FFE 10	FFE 10	FFE 10	P. 318
Thermally insulated long pipe elbow	ABLS 160	ABLS 160	ABLS 160	ABLS 160	ABLS 160	ABLS 160	ABLS 160	P. 154
Sound absorber box	SB 12/16	SB 12/16	SB 12/16	SB 12/16	SB 12/16	SB 12/16	SB 12/16	P. 320
Tubular sound absorber	RSR 10 RSR 12 RSR 16 RSR 16/50	RSR 10 RSR 12 RSR 16 RSR 16/50	RSR 10 RSR 12 RSR 16 RSR 16/50	RSR 10 RSR 12 RSR 16 RSR 16/50	RSR 10 RSR 12 RSR 16 RSR 16/50	RSR 10 RSR 12 RSR 16 RSR 16/50	RSR 10 RSR 12 RSR 16 RSR 16/50	P. 320
Slide-in sound absorber	SDE 8 SDE 10 SDE 12	SDE 8 SDE 10 SDE 12	SDE 8 SDE 10 SDE 12	SDE 8 SDE 10 SDE 12	SDE 8 SDE 10 SDE 12	SDE 8 SDE 10 SDE 12	SDE 8 SDE 10 SDE 12	P. 321
Electrical air heater	ERH 16-2	ERH 16-2	ERH 16-2	ERH 16-2	ERH 16-2	ERH 16-2	ERH 16-2	P. 323
Water air heater	WRH 16-2	WRH 16-2	WRH 16-2	WRH 16-2	WRH 16-2	WRH 16-2	WRH 16-2	P. 325
Air filter	TFE 16-4 TFE 16-5 TFE 16-7	TFE 16-4 TFE 16-5 TFE 16-7	TFE 16-4 TFE 16-5 TFE 16-7	TFE 16-4 TFE 16-5 TFE 16-7	TFE 16-4 TFE 16-5 TFE 16-7	TFE 16-4 TFE 16-5 TFE 16-7	TFE 16-4 TFE 16-5 TFE 16-7	P. 227, P. 228
Radio switch	XS 1	XS 1	XS 1	XS 1	XS 1	XS 1	XS 1	P. 350
Radio receiver	XE 1	XE 1	XE 1	XE 1	XE 1	XE 1	XE 1	P. 350
Thermostat	TH 10	TH 10	TH 10	TH 10	TH 10	TH 10	TH 10	P. 344
Temperature control system	ETL 16 P	ETL 16 P	ETL 16 P	ETL 16 P	ETL 16 P	ETL 16 P	ETL 16 P	P. 346
Channel sensor	FL 30 P	FL 30 P	FL 30 P	FL 30 P	FL 30 P	FL 30 P	FL 30 P	P. 346
Room sensor	FR 30 P	FR 30 P	FR 30 P	FR 30 P	FR 30 P	FR 30 P	FR 30 P	P. 347
Air flow monitor	LW 9	LW 9	LW 9	LW 9	LW 9	LW 9	LW 9	P. 347
Humidity and temperature sensor	FFT 30 K	FFT 30 K	FFT 30 K	FFT 30 K	FFT 30 K	FFT 30 K	FFT 30 K	P. 347
CO₂ sensor	SKD	SKD	SKD	SKD	SKD	SKD	SKD	P. 349
Air quality controller	EAQ 10/3	EAQ 10/3	EAQ 10/3	EAQ 10/3	EAQ 10/3	EAQ 10/3	EAQ 10/3	P. 150

WS 470 centralised ventilation unit



Models

- B: With integrated, automatically controlled, 100% bypass with position feedback.
- K: With integrated, demand-controlled, electrical PTC preheating register.
- KB: With PTC preheating register and bypass.
- ET: With integrated, anti-microbial enthalpy heat exchanger for transferring humidity and heat.
- BET: With bypass and enthalpy heat exchanger.
- KET: With PTC preheating register and enthalpy heat exchanger.
- KBET: With PTC preheating register, bypass and enthalpy heat exchanger.

Features

- Highly efficient, intelligent, centralised ventilation unit with heat recovery for comfort ventilation.
- Compact and very quiet unit for wall / standalone mounting (optional).
- An easily accessible USB port for service/start-up characterises all unit variants.
- DC motors with integrated, automatic volumetric flow regulation for constant air volume ("volumetric flow consistency").
- The DC motors can be operated via the optional additional "pressure constant" PCB ZP 2.
- Good customer service/ease of use thanks to modern unit module technology.

- Good flexibility thanks to various equipment and connection options.
- Housing: Sheet steel, powder coated.
- Colour: white aluminium.
- Inner cladding made from temperature-resistant and extremely noise- and heat-insulating plastic (EPP). The material is also characterised by its hygienic and non-hygroscopic properties. Tested by the Institut für Lufthygiene Berlin [Berlin Institute for Air Hygiene] according to VDI 6022 Part 1.
- Additional noise-insulating cladding in the supply air guide.
- Maximum air tightness.
- Simple filter change is possible without tools.
- 4 DN 160 duct connections.
- Can be equipped with plug-in connectors or duct bend (accessories).
- All unit variants (e.g. "K") can also be converted into other unit variants (e.g. "KET") later on using optional components.
- DIBT approval.
- PH certification.

RLS 1 WR control unit

- **Included in the scope of delivery.**
- Switching the 4 ventilation levels, maintenance display, fault messages.
- Other control units can be connected in parallel.

Touch screen control unit

RLS T1 WS

- **Optional.**
- Up to 6 operating modes possible.
- 2 automatic operating modes (Auto Sensor / Auto Time).
- 4 manual operating modes (ECO exhaust air / ECO supply air / MANUAL / OFF).

air@home

- The units have an integrated web server and can be controlled with an app when at home or out and about, e.g. using a smartphone.
- Live reports, user administration, control and setting using web tool, via tablet, laptop and PC.
- Settings:
 - Needs-based automatic mode / Time-controlled automatic mode.
 - Manual operation / OFF.
 - ECO mode supply air or ECO mode exhaust air.
 - Filter queries, error messages.
- Registration needed. For more info, see "www.air-home.de".

Controller

- 3 temperature sensors in outside-, outgoing and supply air connections.
- 1 combination sensor (temperature and humidity) in exhaust air connection.
- Integrated excess humidity avoidance function.
- Continuously variable needs-based adaptation of air volumes.
- Multi-function contact for controlling EW brine earth heat exchanger (uncontrolled pump), operating and fault display, preheating and postheating register, shutters.
- Can be extended with other PCBs (e.g. ZP 1, ZP 2).

ModBus

- Integrated MODBUS interface enables integration in the building control technology.

EnOcean

- Optional EnOcean plug-in module E-SM for integrating the ventilation unit into "EnOcean world" "www.enocean-alliance.org".

KNX

- Optional KNX plug-in module K-SM allows for connection to building control technology, "www.knx.org".

Heat exchanger

- Highly efficient cross-counter-flow plate heat exchanger made of plastic material (PS), and/or washable, anti-microbial enthalpy heat exchanger made of plastic (PS).

Energy-efficient fans

- 2 radial direct current fans, curved to the front in the supply air / outgoing air.
- 4 ventilation levels can be adjusted continuously between 80.. 470 m³/h.

Mounting instructions

- Easy, very time-saving mounting with the wall bracket included in the scope of delivery.
- Housing cover is easy to remove using practical magnetic locks.
- Provide sound absorbers on the inlet and outlet sides.

Electrical connection

- Ready for service with on/off switch.
- Prepared for assembly-friendly connection of sensors.
- Extendible, functional electronics box allows optional additional circuit boards (ZP 1 and ZP 2) to be fitted with ease.

Condensation drain

- Condensation drain (1 1/2" screen valve).
- Connection to an optional siphon (DN40).
- Easy-clean condensate tank integrated in EPP housing.

Frost protection

- Prevents the heat exchanger from freezing up at low temperatures.
- For "K" unit models, using integrated, demand-controlled, electrical PTC preheating register.
- For "non-K" unit models, by switching off the supply air fan.
- Recommendation: For "non-K" unit models, combine with heat recovery with a brine earth heat exchanger.



Energy efficiency class

Technical data

Article	Art. No.	Max. degree of heat provision in accordance with DIN EN 13141-7 (A7) %	U _{nom} V	f _{nom} Hz	Con- nection dia- meter mm	Air flow volume m ³ /h	Power con- sumption in accordance with DIN EN 13141-7 (A7) W	Stand-by power con- sumption	I _{max} A	Housing emission sound pressure level dB(A)	Humidity conditions with enthalpy heat exchanger in accordance with DIN EN 13141-7 (A2) %	Filter class	Degree of pro- tection IP	SPI value in accord- ance with DIN EN 13141-7 (A7) Wh/m ³	Weight kg
WS 470 K	0095.0230	96	230	50/60	160	80 - 470	87	< 1 W	11.5	42 ¹⁾	–	G4/F7	40	0.26	67
WS 470 B	0095.0229	96	230	50/60	160	80 - 470	87	< 1 W	2	42 ¹⁾	–	G4/F7	40	0.26	67
WS 470 KB	0095.0231	96	230	50/60	160	80 - 470	87	< 1 W	11.5	42 ¹⁾	–	G4/F7	40	0.26	67
WS 470 ET	0095.0232	93	230	50/60	160	80 - 470	85	< 1 W	2	42 ¹⁾	57	G4/F7	40	0.25	73
WS 470 KET	0095.0234	93	230	50/60	160	80 - 470	85	< 1 W	11.5	42 ¹⁾	57	G4/F7	40	0.25	73
WS 470 BET	0095.0233	93	230	50/60	160	80 - 470	85	< 1 W	2	42 ¹⁾	57	G4/F7	40	0.25	73
WS 470 KBET	0095.0235	93	230	50/60	160	80 - 470	85	< 1 W	11.5	42 ¹⁾	57	G4/F7	40	0.25	73

¹⁾ Spacing 1m, sound absorption 10 m²
Equipment

Article	Bypass	Pre- heater	Enthalpy heat ex- changer	Anti- freeze circuit	Summer circuit	Filter moni- toring	Hu- midity control	CO ₂ - control (op- tional)	Air quality control (optional)	MODBUS interface	KNX con- nection (op- tional)	Control unit included in scope of deliv- ery.	Control unit (optional)	EnOcean wireless integration (optional)	Mobile control
WS 470 K	No	inte- grated	No	yes	ECO exhaust air / ECO supply air	with time control	inte- grated	SKD	EAQ 10/3	integrated	K-SM	RLS 1 WR, App	RLS T1 WS	E-SM	yes
WS 470 B	yes	No	No	yes	ECO exhaust air / ECO supply air	with time control	inte- grated	SKD	EAQ 10/3	integrated	K-SM	RLS 1 WR, App	RLS T1 WS	E-SM	yes
WS 470 KB	yes	inte- grated	No	yes	ECO exhaust air / ECO supply air	with time control	inte- grated	SKD	EAQ 10/3	integrated	K-SM	RLS 1 WR, App	RLS T1 WS	E-SM	yes
WS 470 ET	No	No	yes	yes	ECO exhaust air / ECO supply air	with time control	inte- grated	SKD	EAQ 10/3	integrated	K-SM	RLS 1 WR, App	RLS T1 WS	E-SM	yes
WS 470 KET	No	inte- grated	yes	yes	ECO exhaust air / ECO supply air	with time control	inte- grated	SKD	EAQ 10/3	integrated	K-SM	RLS 1 WR, App	RLS T1 WS	E-SM	yes
WS 470 BET	yes	No	yes	yes	ECO exhaust air / ECO supply air	with time control	inte- grated	SKD	EAQ 10/3	integrated	K-SM	RLS 1 WR, App	RLS T1 WS	E-SM	yes
WS 470 KBET	yes	inte- grated	yes	yes	ECO exhaust air / ECO supply air	with time control	inte- grated	SKD	EAQ 10/3	integrated	K-SM	RLS 1 WR, App	RLS T1 WS	E-SM	yes

WS 470 centralised ventilation unit



Dimensions [mm]

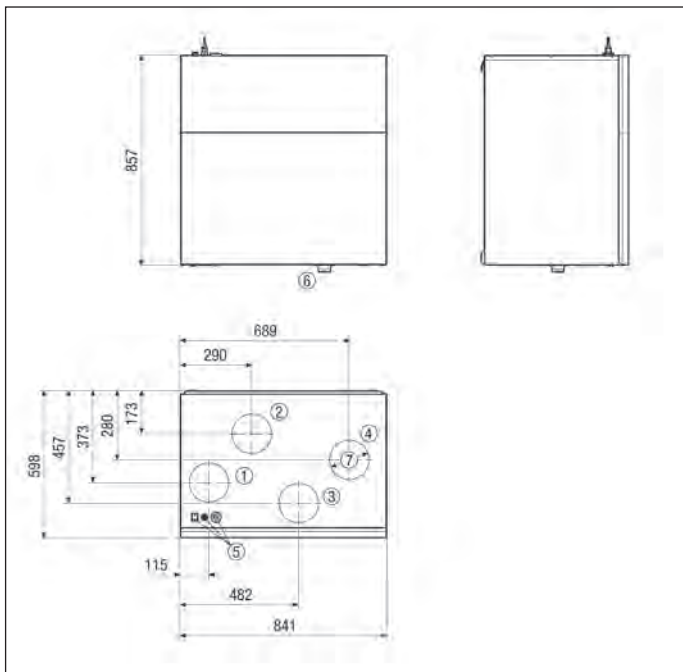

- ① DN 160 supply air
- ② DN 160 exhaust air
- ③ DN 160 outside air
- ④ DN 160 outgoing air
- ⑤ Unit switches / electric connections
- ⑥ Condensation drain
- ⑦ for DN 160 plug connector

Characteristic curve

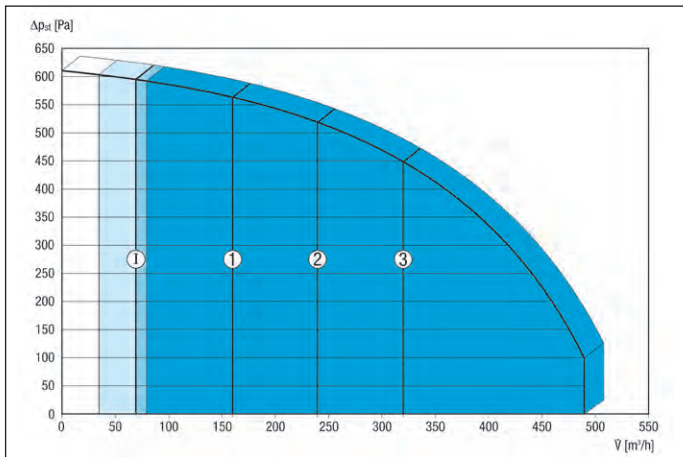

The figures shown indicate the preset ventilation levels ("factory settings").
 1 = 160 m³/h, reduced ventilation (RV)
 2 = 240 m³/h, nominal ventilation (NV)
 3 = 320 m³/h, intensive ventilation (IV)
 I = Interval or "humidity protection operation" depending on RV

Individual settings available:
 RV = 80 m³/h - 470 m³/h
 NV = 80 m³/h - 470 m³/h
 IV = 80 m³/h - 470 m³/h

Essential condition: RV < NV < IV !

Important accessories

Plug connector for duct



P. 143

Plug connector incl. lip seal, DN 160, for connecting folded spiral-seams ducts to the WR 310/WR 410, WS 320 and WS 470 central ventilation units

SVR 160 0055.0185

90° elbow, drawn



P. 143

90° elbow, drawn, incl. lip seal, DN 160, for connecting folded spiral-seams ducts to the WR 310/WR 410, WS 320 and WS 470 central ventilation units. Alternative to the SVR 160 plug connector

B90-160 0055.0314

Assembly feet



P. 143

Assembly feet for upright installation of WR 310/WR 410, WS 320 and WS 470 centralised ventilation units

WS-MF 320/470 0092.0558

Siphon



P. 144

1 1/2" siphon for screen valve connection for the WR 310/WR 410, WS 320 and WS 470 centralised ventilation units

WS-SI 320/470 0092.0564

Room air control



P. 148

Optional touch control unit for WS 160 Flat, WS 170 KBR./WS170 KBL., WR 310/WR 410, WS320 and WS 470 centralised ventilation units. Setting time programs, operating modes, ventilation levels, temperatures etc. with integrated NTC room temperature sensor, mini USB port and 4-wire bus connection

RLS T1 WS 0157.0835

Air filters, replacement

P. 144

Replacement air filter for WR 310/WR 410, WS 320 and WS 470 centralised ventilation units

WSF-AKF 320/470 0092.0563
 WSG 320/470 0092.0559
 WSG 320/470 0092.0560

Replacement filter mat

P. 144

Replacement filter mats for WR 310/WR 410, WS 320 and WS 470 centralised ventilation units, filter class G4, 10 items

WSG-EG 320/470 0092.0562

Push-in frame for air filter



P. 144

Push-in frame for WSG 320/470 air filter, 1 item

WSG-ES 320/470 0092.0561

Preheating register



P. 143

Electric PTC preheating register for continuous operation of the WR 310/WR 410, WS 320 and WS 470 centralised ventilation units at very low outside temperatures

WS-VH 320/470 0093.1266

Bypass for heat exchanger



P. 144

Automatic 100% bypass with position feedback for WR 310/WR 410, WS 320 and WS 470 centralised ventilation units

WS-BP 320/470 0093.1265

Important accessories
Enocean plug-in module

P. 151

The E-SM communication module allows the ventilation unit to be controlled with the EnOcean wireless standard. Once the plug-in module has been fitted on the basic PCB, appropriate wireless sensors / wireless control units (see Enocean EEP list) can be taught in on the control. For WS 160 Flat, WS 170 KBR../WS 170 KBL..., WR 310/WR 410, WS 320 and WS 470 centralised ventilation units

E-SM 0092.0556

KNX plug-in module

P. 151

The K-SM is fitted on the basic PCB. This module then allows the unit control to be integrated in a KNX system (e.g. building control technology). For WS 160 Flat, WS 170 KBR../WS 170 KBL..., WR 310/WR 410, WS 320 and WS 470 centralised ventilation units

K-SM 0092.0557

Additional circuit board

P. 151

Additional circuit board for WS 160 Flat, WS 170 KBR../WS 170 KBL..., WR 310/WR 410, WS 320 and WS 470 centralised ventilation units. For example, to control an external postheating register or a controlled pump for brine earth heat exchangers

ZP 1 0092.0554

Additional circuit board

P. 151

Additional circuit board for WS 160 Flat, WS 170 KBR../WS 170 KBL..., WR 310/WR 410, WS 320 and WS 470 centralised ventilation units. For example, for operating the fans with pressure consistency or for differential pressure-controlled filter monitoring

ZP 2 0092.0555

CO₂ sensor

P. 349

Sensor for measuring the carbon dioxide concentration in the air, CO₂ measurement range from 500 - 2,000 ppm, 0 - 10 V output

SKD 0157.0345

Sound power level in octave range

	63 Hz	125 Hz	250 Hz	500 Hz	1 kHz	2 kHz	4 kHz	8 kHz	Total
L _{LWA2} [dB (A)]	30	38	43	46	46	38	27	20	50
L _{LWA5} [dB (A)]	43	44	41	41	45	37	28	14	50
L _{LWA6} [dB (A)]	50	55	56	55	55	41	36	35	62

L_{LWA5}, L_{LWA6} = sound power level emitted to the free surroundings.

Measured at a subsequent operating point on the connections facing the room.

L_{LWA5} Exhaust air connections, L_{LWA6} Supply air connections.

Operating point: Reference volumetric flow 340 m³/h and external pressure 50 Pa

L_{LWA2} = housing sound power level in dB.

L_{LWA5} = free inlet sound power level in dB.

L_{LWA6} = free outlet sound power level in dB.

Accessories selection table

	WS 470 K	WS 470 B	WS 470 KB	WS 470 ET	WS 470 KET	WS 470 BET	WS 470 KBET	see
Plug connector for duct	SVR 160	SVR 160	SVR 160	SVR 160	SVR 160	SVR 160	SVR 160	P. 143
90° elbow, drawn	B90-160	B90-160	B90-160	B90-160	B90-160	B90-160	B90-160	P. 143
Assembly feet	WS-MF 320/470	WS-MF 320/470	WS-MF 320/470	WS-MF 320/470	WS-MF 320/470	WS-MF 320/470	WS-MF 320/470	P. 143
Siphon	WS-SI 320/470	WS-SI 320/470	WS-SI 320/470	WS-SI 320/470	WS-SI 320/470	WS-SI 320/470	WS-SI 320/470	P. 144
Preheating register	-	WS-VH 320/470	-	WS-VH 320/470	-	WS-VH 320/470	-	P. 143
Bypass for heat exchanger	WS-BP 320/470	-	-	WS-BP 320/470	WS-BP 320/470	-	-	P. 144
Air filter, replacement	WSF-AKF 320/470 WSF 320/470 WSG 320/470	WSF-AKF 320/470 WSF 320/470 WSG 320/470	WSF-AKF 320/470 WSF 320/470 WSG 320/470	WSF-AKF 320/470 WSF 320/470 WSG 320/470	WSF-AKF 320/470 WSF 320/470 WSG 320/470	WSF-AKF 320/470 WSF 320/470 WSG 320/470	WSF-AKF 320/470 WSF 320/470 WSG 320/470	P. 144
Replacement filter mat	WSG-EG 320/470	WSG-EG 320/470	WSG-EG 320/470	WSG-EG 320/470	WSG-EG 320/470	WSG-EG 320/470	WSG-EG 320/470	P. 144
Push-in frame for air filter	WSG-ES 320/470	WSG-ES 320/470	WSG-ES 320/470	WSG-ES 320/470	WSG-ES 320/470	WSG-ES 320/470	WSG-ES 320/470	P. 144
Room air control	RLS 1 WR RLS T1 WS	RLS 1 WR RLS T1 WS	RLS 1 WR RLS T1 WS	RLS 1 WR RLS T1 WS	RLS 1 WR RLS T1 WS	RLS 1 WR RLS T1 WS	RLS 1 WR RLS T1 WS	P. 148
Enocean plug-in module	E-SM	E-SM	E-SM	E-SM	E-SM	E-SM	E-SM	P. 151
KNX plug-in module	K-SM	K-SM	K-SM	K-SM	K-SM	K-SM	K-SM	P. 151
Additional circuit board	ZP 1 ZP 2	ZP 1 ZP 2	ZP 1 ZP 2	ZP 1 ZP 2	ZP 1 ZP 2	ZP 1 ZP 2	ZP 1 ZP 2	P. 151
Radio switch	DS RC	DS RC	DS RC	DS RC	DS RC	DS RC	DS RC	P. 149
MAICOTherm ventilation duct system, thermally insulated	MT	MT	MT	MT	MT	MT	MT	P. 152
MAICOFlex ventilation duct system, round	MF	MF	MF	MF	MF	MF	MF	P. 158
MAICO FFS ventilation duct system, flat	FFS	FFS	FFS	FFS	FFS	FFS	FFS	P. 164

WS 470 centralised ventilation unit

	WS 470 K	WS 470 B	WS 470 KB	WS 470 ET	WS 470 KET	WS 470 BET	WS 470 KBET	see
Brine earth heat exchanger	EW	EW	EW	EW	EW	EW	EW	P. 156
Shutter	AS 20	AS 20	AS 20	AS 20	AS 20	AS 20	AS 20	P. 297
External grille	MGR 160 alu	MGR 160 alu	MGR 160 alu	MGR 160 alu	MGR 160 alu	MGR 160 alu	MGR 160 alu	P. 304
Stainless steel cowl	LH-V2A 16	LH-V2A 16	LH-V2A 16	LH-V2A 16	LH-V2A 16	LH-V2A 16	LH-V2A 16	P. 304
Outside air wall connection	KW-AL 16E KW-AL 16W KW-AL 20E KW-AL 20W	KW-AL 16E KW-AL 16W KW-AL 20E KW-AL 20W	KW-AL 16E KW-AL 16W KW-AL 20E KW-AL 20W	KW-AL 16E KW-AL 16W KW-AL 20E KW-AL 20W	KW-AL 16E KW-AL 16W KW-AL 20E KW-AL 20W	KW-AL 16E KW-AL 16W KW-AL 20E KW-AL 20W	KW-AL 16E KW-AL 16W KW-AL 20E KW-AL 20W	P. 154
Outgoing air wall connection	KW-FL 16E KW-FL 16W KW-FL 20E KW-FL 20W	KW-FL 16E KW-FL 16W KW-FL 20E KW-FL 20W	KW-FL 16E KW-FL 16W KW-FL 20E KW-FL 20W	KW-FL 16E KW-FL 16W KW-FL 20E KW-FL 20W	KW-FL 16E KW-FL 16W KW-FL 20E KW-FL 20W	KW-FL 16E KW-FL 16W KW-FL 20E KW-FL 20W	KW-FL 16E KW-FL 16W KW-FL 20E KW-FL 20W	P. 155
Combi-wall connections	KWH 16 L KWH 16 R KWH 20 L KWH 20 R	KWH 16 L KWH 16 R KWH 20 L KWH 20 R	KWH 16 L KWH 16 R KWH 20 L KWH 20 R	KWH 16 L KWH 16 R KWH 20 L KWH 20 R	KWH 16 L KWH 16 R KWH 20 L KWH 20 R	KWH 16 L KWH 16 R KWH 20 L KWH 20 R	KWH 16 L KWH 16 R KWH 20 L KWH 20 R	P. 155
Roof outlet	DF 160 S	DF 160 S	DF 160 S	DF 160 S	DF 160 S	DF 160 S	DF 160 S	P. 306
Roofing tile	DP 160 SB DP 160 A	DP 160 SB DP 160 A	DP 160 SB DP 160 A	DP 160 SB DP 160 A	DP 160 SB DP 160 A	DP 160 SB DP 160 A	DP 160 SB DP 160 A	P. 306
Mounting clamp	BS 160	BS 160	BS 160	BS 160	BS 160	BS 160	BS 160	P. 306
Rain protection grille	RG 160	RG 160	RG 160	RG 160	RG 160	RG 160	RG 160	P. 306
Door ventilation grille	MLK 30 white MLK 45 white	MLK 30 white MLK 45 white	MLK 30 white MLK 45 white	MLK 30 white MLK 45 white	MLK 30 white MLK 45 white	MLK 30 white MLK 45 white	MLK 30 white MLK 45 white	P. 312
Disk valve, synthetic material	TK 10 TK 12	TK 10 TK 12	TK 10 TK 12	TK 10 TK 12	TK 10 TK 12	TK 10 TK 12	TK 10 TK 12	P. 316
Disk valve, stainless steel	TM-V2A 10 TM-V2A 12	TM-V2A 10 TM-V2A 12	TM-V2A 10 TM-V2A 12	TM-V2A 10 TM-V2A 12	TM-V2A 10 TM-V2A 12	TM-V2A 10 TM-V2A 12	TM-V2A 10 TM-V2A 12	P. 316
Disk valve, metal	TM 10 TM 12 TFA 10 TFA 12 TFZ 10 TFZ 12	TM 10 TM 12 TFA 10 TFA 12 TFZ 10 TFZ 12	TM 10 TM 12 TFA 10 TFA 12 TFZ 10 TFZ 12	TM 10 TM 12 TFA 10 TFA 12 TFZ 10 TFZ 12	TM 10 TM 12 TFA 10 TFA 12 TFZ 10 TFZ 12	TM 10 TM 12 TFA 10 TFA 12 TFZ 10 TFZ 12	TM 10 TM 12 TFA 10 TFA 12 TFZ 10 TFZ 12	P. 316, P. 317
Mounting frame for TFA/TFZ	EBR-D 10 EBR-D 12	EBR-D 10 EBR-D 12	EBR-D 10 EBR-D 12	EBR-D 10 EBR-D 12	EBR-D 10 EBR-D 12	EBR-D 10 EBR-D 12	EBR-D 10 EBR-D 12	P. 318
Blower nozzle	WD 10 W WD 10 D	WD 10 W WD 10 D	WD 10 W WD 10 D	WD 10 W WD 10 D	WD 10 W WD 10 D	WD 10 W WD 10 D	WD 10 W WD 10 D	P. 318, P. 319
Supply air valve	ZWVQ 10 ZWVQ 12	ZWVQ 10 ZWVQ 12	ZWVQ 10 ZWVQ 12	ZWVQ 10 ZWVQ 12	ZWVQ 10 ZWVQ 12	ZWVQ 10 ZWVQ 12	ZWVQ 10 ZWVQ 12	P. 319
Exhaust and supply air valve	AZV 100	AZV 100	AZV 100	AZV 100	AZV 100	AZV 100	AZV 100	P. 315
Grease filter element for exhaust air	FFE 10	FFE 10	FFE 10	FFE 10	FFE 10	FFE 10	FFE 10	P. 318
Thermally insulated long pipe elbow	ABLS 160	ABLS 160	ABLS 160	ABLS 160	ABLS 160	ABLS 160	ABLS 160	P. 154
Sound absorber box	SB 12/16	SB 12/16	SB 12/16	SB 12/16	SB 12/16	SB 12/16	SB 12/16	P. 320
Tubular sound absorber	RSR 10 RSR 12 RSR 16 RSR 16/50	RSR 10 RSR 12 RSR 16 RSR 16/50	RSR 10 RSR 12 RSR 16 RSR 16/50	RSR 10 RSR 12 RSR 16 RSR 16/50	RSR 10 RSR 12 RSR 16 RSR 16/50	RSR 10 RSR 12 RSR 16 RSR 16/50	RSR 10 RSR 12 RSR 16 RSR 16/50	P. 320
Slide-in sound absorber	SDE 8 SDE 10 SDE 12	SDE 8 SDE 10 SDE 12	SDE 8 SDE 10 SDE 12	SDE 8 SDE 10 SDE 12	SDE 8 SDE 10 SDE 12	SDE 8 SDE 10 SDE 12	SDE 8 SDE 10 SDE 12	P. 321
Electrical air heater	ERH 16-2	ERH 16-2	ERH 16-2	ERH 16-2	ERH 16-2	ERH 16-2	ERH 16-2	P. 323
Water air heater	WRH 16-2	WRH 16-2	WRH 16-2	WRH 16-2	WRH 16-2	WRH 16-2	WRH 16-2	P. 325
Air filter	TFE 16-4 TFE 16-5 TFE 16-7	TFE 16-4 TFE 16-5 TFE 16-7	TFE 16-4 TFE 16-5 TFE 16-7	TFE 16-4 TFE 16-5 TFE 16-7	TFE 16-4 TFE 16-5 TFE 16-7	TFE 16-4 TFE 16-5 TFE 16-7	TFE 16-4 TFE 16-5 TFE 16-7	P. 327, P. 328
Radio switch	XS 1	XS 1	XS 1	XS 1	XS 1	XS 1	XS 1	P. 350
Radio receiver	XE 1	XE 1	XE 1	XE 1	XE 1	XE 1	XE 1	P. 350
Thermostat	TH 10	TH 10	TH 10	TH 10	TH 10	TH 10	TH 10	P. 344
Temperature control system	ETL 16 P	ETL 16 P	ETL 16 P	ETL 16 P	ETL 16 P	ETL 16 P	ETL 16 P	P. 346
Channel sensor	FL 30 P	FL 30 P	FL 30 P	FL 30 P	FL 30 P	FL 30 P	FL 30 P	P. 346
Room sensor	FR 30 P	FR 30 P	FR 30 P	FR 30 P	FR 30 P	FR 30 P	FR 30 P	P. 347
Air flow monitor	LW 9	LW 9	LW 9	LW 9	LW 9	LW 9	LW 9	P. 347
Humidity and temperature sensor	FFT 30 K	FFT 30 K	FFT 30 K	FFT 30 K	FFT 30 K	FFT 30 K	FFT 30 K	P. 347
CO₂ sensor	SKD	SKD	SKD	SKD	SKD	SKD	SKD	P. 349
Air quality controller	EAQ 10/3	EAQ 10/3	EAQ 10/3	EAQ 10/3	EAQ 10/3	EAQ 10/3	EAQ 10/3	P. 150

**Plug connector for duct
SVR 160**



- Plug connector for folded spiral-seams ducts, including lip seals.
- E.g. for connecting the WR 310 / WR 410, WS 320 and WS 470 centralised ventilation units to folded spiral-seams ducts..

Features

Nominal size	160 mm
Material	Sheet steel
Max. ambient temperature	60 °C

Article	Art. No.
SVR 160	0055.0185

**90° elbow, drawn
B90-160**



- 90° elbow, drawn, incl. lip seals. For folded spiral-seam ducts.
- E.g. for connecting the WR 310 / WR 410, WS 320 and WS 470 ventilation units to folded spiral-seams as alternative to SVR 160 plug connector.

Dimensions [mm]

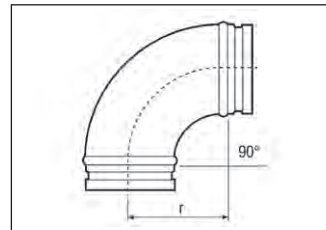

r = 160

Features

Nominal size	160 mm
Material	Sheet steel
Max. ambient temperature	60 °C

Article	Art. No.
B90-160	0055.0314

Article	DN mm
B90-160	160

**Assembly feet
WS-MF 320/470**

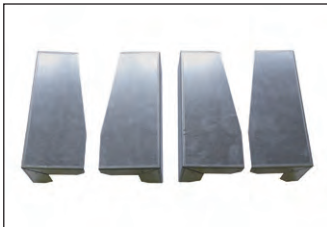

- Assembly feet for upright installation of WR 310/WR 410, WS 320 and WS 470 centralised ventilation units.

Dimensions [mm]

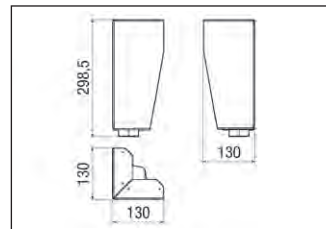

Features

Material	Steel, galvanised
----------	-------------------

Article	Art. No.
WS-MF 320/470	0092.0558

**Preheating register
WS-VH 320/470**



- Electric PTC preheating register for continuous operation of the WR 310/WR 410, WS 320 and WS 470 centralised ventilation units at very low outside temperatures.

Features

U _{nom}	230 VAC
f _{nom}	50 Hz
Degree of protection	IP 00
Heater power rating	1,800 W
Width	169 mm
Height	81 mm
Depth	361 mm

Article	Art. No.
WS-VH 320/470	0093.1266

**Bypass for heat exchanger
WS-BP 320/470**



- Automatic 100% bypass with position feedback for WR 310/WR 410, WS 320 and WS 470 centralised ventilation units.

Features

Material	EPP
Width	193 mm
Height	95 mm
Depth	505 mm

Article	Art. No.
WS-BP 320/470	0093.1265

**Siphon
WS-SI 320/470**



- 1 1/2" siphon for screen valve connection for the WR 310/WR 410, WS 320 and WS 470 centralised ventilation units.

Features

Material	Polypropylene (PP)
Siphon diameter	1 1/2" x DN 50

Article	Art. No.
WS-SI 320/470	0092.0564

**Air filters, replacement
WSF/WSG**

- WSF 320/470: Pollen filter for the WR 310/WR 410, WS 320 and WS 470 centralised ventilation units.
- WSG 320/470:
 - Replacement air filter for the WR 310/WR 410, WS 320 and WS 470 centralised ventilation units.
 - Consisting of high-quality, corrugated filters for a long service life.
 - No additional frame required.
- WSG-EG 320/470:
 - Replacement air filter mats for the WR 310/WR 410, WS 320 and WS 470 centralised ventilation units.
 - For placing in WSG-ES 320/470 push-in frame.
- WSF-AKF 320/470: Active carbon filter for the WR 310/WR 410, WS 320 and WS 470 centralised ventilation units.

Article	Art. No.	Packing unit	Filter class
WSF 320/470	0092.0559	1 x F7	F7
WSG 320/470	0092.0560	2 x G4	G4
WSG-EG 320/470	0092.0562	10 x G4	G4
WSF-AKF 320/470	0092.0563	1 x active carbon, M5	M5/active carbon

Article	Width mm	Height mm	Depth mm
WSF 320/470	506	164	48
WSG 320/470	507	165	50
WSG-EG 320/470	505	170	18
WSF-AKF 320/470	507	163	48

**Push-in frame for air filter
WSG-ES 320/470**

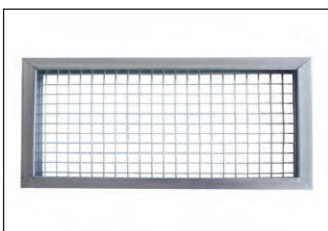

- Push-in frame to position the WSG-EG 320/470 replacement air filter mats.

Features

Material	Steel, galvanised
Width	505 mm
Height	170 mm
Depth	20 mm

Article	Art. No.
WSG-ES 320/470	0092.0561

Features

- Special energy savings due to DC motors with EC technology.
- With automatic volumetric flow regulation for constant air quantities.
- Sheet steel, powder coated housing.
- Colour pearl light grey.
- Inner coating of heat resistant plastic material (EPP), non-hygroscopic.
- Simple filter change is possible without tools.
- 2 x G4 filter, 1 x F7 filter.
- 2 DN 250 duct connections with double lip seals each. For directly connecting up tubular sound absorbers.
- DIBT approval and PH certification.
- Connection to KNX systems possible.

Control unit

- **RLS 1 WR control unit is included in the scope of delivery as standard.**
- Filter change warning displayed on the control unit.
- Set the 4 ventilation levels using buttons.
- Fault display.
- Other control units can be connected in parallel.

Heat exchanger

- Cross-counterflow plate heat exchanger made of aluminium.
- The heat exchanger can be removed easily once the front plate has been unscrewed.
- The heat exchanger can be easily cleaned using water.

Energy-efficient fans

- 2 centrifugal DC fans, curved to the front. In the supply or exhaust air.
- 4 ventilation levels:
 - 1 = Interval / vacation operation for humidity protection
 - 2 = Reduced ventilation
 - 3 = Intensive / party operation
- The air volume is linearly adjustable.

Mounting instructions

- Feet for installation.
- Ensure access to condensation connection on side.
- Housing covers can be unscrewed.
- Provide sound absorbers on the inlet and outlet sides.

Electrical connection

- Ready for service.
- Prepared for connection of sensors.
- Potential-free contact e.g. for operating display.
- Central inclusion in KNX/EIB bus possible.

Condensation drain

- Condensation is drained out from the side of the unit. Condensation drain (3/4" hose connection) to connect up to a siphon.
- Stable foamed-in condensation tank.

Plus function (summer operation)

- In eco mode, only the exhaust fan runs, so around 50 % less power is used. Possible with RLS D1 WR digital control.

Frost protection

- Guaranteed frost protection ensures that the heat exchanger does not freeze.
- The frost protection feature switches the supply air fan off when the outgoing air temperature is too low and automatically back on again.
- Recommendation: Combine units with heat recovery with a brine earth heat exchanger.

Technical data

Article	Art. No.	Max. degree of heat provision in accordance with DIN EN 13141-7 (A7) %	U _{nom} V	f _{nom} Hz	Con- nection diame- ter mm	Air flow volume m ³ /h	Power con- sumption in accordance with DIN EN 13141-7 (A7) W	Stand-by power con- sump- tion	I _{max} A	Housing emission sound pressure level dB(A)	Filter class	Degree of pro- tection IP	SPI value in accordance with DIN EN 13141-7 (A7) Wh/m ³	Weight kg
WR 600	0095.0080	89	230	50/60	250	150 - 620	130	< 5 W	3	43/46/50 ¹⁾	G4/F7	00	0.31	89

¹⁾ Spacing 1m, sound absorption 10 m²

Energieeffizienzklasse

WR 600 centralised ventilation unit

Dimensions [mm]

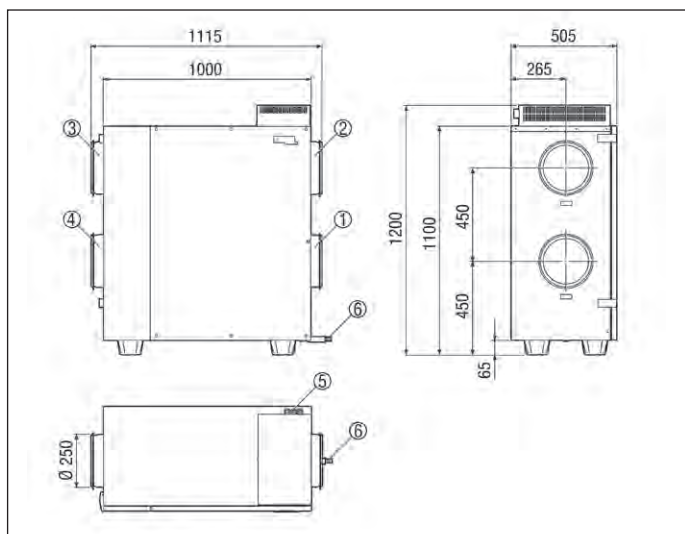

- ① DN 250 outgoing air
- ② DN 250 supply air
- ③ DN 250 exhaust air
- ④ DN 250 outside air
- ⑤ Electrical connection
- ⑥ Condensation drain (3/4" hose connection)

Characteristic curve

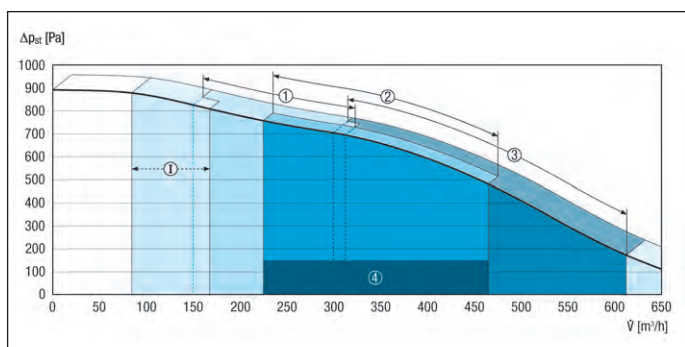

- I - Interval operation
- ① Reduced ventilation
- ② Nominal ventilation
- ③ Intensive / Party operation
- ④ Recommended setting range

Ventilation for humidity protection

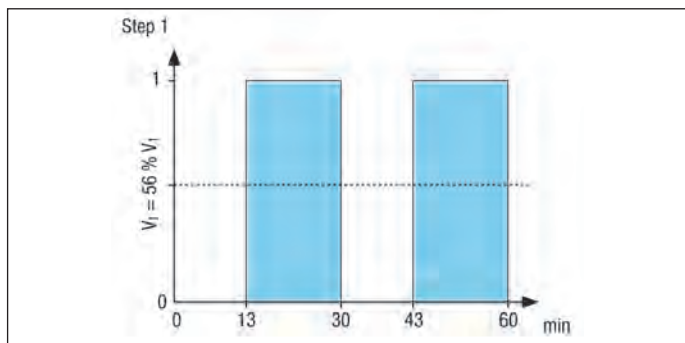

Interval switch for step 1
 17 min to switch on
 13 min to switch off

Important accessories

Summer cassette



P. 147

Summer cassette for the supply of fresh outside air for WR 600 centralised ventilation unit

WRSK 600 0095.0153

Room air control



P. 148

Optional digital control unit for WS 170 R../WS 170 L..., WS 170 KR../WS 170 KL... and WR 600 centralised ventilation units, with timer, filter change and fault displays and summer mode

RLS D1 WR 0157.0828

Air filters, replacement

P. 147

Replacement air filter for centralised ventilation units.

WSF 600 0093.0689
 WSG 600-1 0093.0688

Hygrostats



P. 348

Hygrostat for controlling ventilation systems depending on the relative air humidity

HY 230 0157.0126
 HY 230 I 0157.0127

CO₂ sensor



P. 349

Sensor for measuring the carbon dioxide concentration in the air, CO₂ measurement range from 500 - 2,000 ppm, 0 - 10 V output

SKD 0157.0345

Sound power level in octave range

	63 Hz	125 Hz	250 Hz	500 Hz	1 kHz	2 kHz	4 kHz	8 kHz	Total
L_{LWA2}¹ Level 2 [dB (A)]	33	41	40	42	41	37	31	19	48
L_{LWA5}¹ Level 2 [dB (A)]	38	43	44	42	42	35	25	16	49
L_{LWA6}¹ Level 2 [dB (A)]	38	42	43	42	46	40	26	20	51

L_{LWA5}¹, L_{LWA6}¹ = sound power level emitted to the free surroundings. Measured at a subsequent operating point on the connections facing the room.

L_{LWA5} Exhaust air connections, L_{LWA6} Supply air connections. Operating point, level 2: Air volume 345 m³/h and external pressure 100 Pa

L_{LWA2} = housing sound power level in dB.

L_{LWA5} = free inlet sound power level in dB.

L_{LWA6} = free outlet sound power level in dB.

Accessories selection table

	WR 600	see
Summer cassette	WRSK 600	P. 147
Air filter, replacement	WSF 600, WSG 600-1	P. 147
Room air control	RLS 1 WR, RLS D1 WR	P. 148
MAICOFlex ventilation duct system, round	MF	P. 152
MAICO FFS ventilation duct system, flat	FFS	P. 164
Brine earth heat exchanger	EW	P. 156
Shutter	AS 25	P. 297
External grille	MLZ 25	P. 305
Door ventilation grille	MLK 30 white MLK 45 white	P. 305
Disk valve, synthetic material	TK 10, TK 12	P. 316
Disk valve, stainless steel	TM-V2A 10, TM-V2A 12	P. 316
Disk valve, metal	TM 10, TM 12 TFA 10, TFA 12 TFZ 10, TFZ 12	P. 316, P. 317
Mounting frame for TFA/TFZ	EBR-D 10 EBR-D 12	P. 318
Blower nozzle	WD 10 W, WD 10 D	P. 318, P. 319
Supply air valve	ZWVQ 10, ZWVQ 12	P. 319
Exhaust and supply air valve	AZV 100	P. 315
Grease filter element for exhaust air	FFE 10	P. 318
Tubular sound absorber	RSR 10, RSR 12, RSR 25/50	P. 320
Slide-in sound absorber	SDE 8, SDE 10, SDE 12, SDE 16	P. 321
Electrical air heater	DRH 25-6	P. 323
Water air heater	WRH 25-4	P. 325
Air filter	TFE 25-4, TFE 25-5, TFE 25-7	P. 327, P. 328
Contactors	US 16 T	P. 337
Radio switch	XS 1	P. 350
Radio receiver	XE 1	P. 350
Thermostat	TH 10	P. 344
Temperature control system	ETL 16 P	P. 346
Channel sensor	FL 30 P	P. 346
Room sensor	FR 30 P	P. 347
Air flow monitor	LW 9	P. 347
Hygrostat	HY 230, HY 230 I	P. 348
CO ₂ sensor	SKD	P. 349
Air quality controller	EAQ 10/2	P. 150

Accessories for WR 600
**Summer cassette
WRSK 600**

Article	Art. No.
WRSK 600	0095.0153

- Summer cassette for WR 600 ventilation unit.
- For the supply of fresh outside air without using the heat exchange process during summer operation.
- Existing heat exchanger should be replaced with summer cassette.

Features

Material	Aluminium
Width	630 mm
Height	425 mm
Depth	390 mm

**Air filters, replacement
WSF/WSG**

- Replacement air filter for WR 600 centralised ventilation unit.

Article	Art. No.	Packing unit	Filter class	Article	Width mm	Height mm	Depth mm
WSF 600	0093.0689	2 x G4, 1 x F7	G4/F7	WSF 600	435	375	48
WSG 600-1	0093.0688	4 x G4	G4	WSG 600-1	430	370	14

**Room air control
RLS 1 WR**



- Included in scope of delivery of WS 160 Flat, WS 170, WR 310 / WR 410, WS 320, WS 470 and WR 600 ventilation units.
- Other control units can be connected in parallel.
- 4 ventilation levels can be set using buttons.
- With LED-based filter change message.
- With LED-based fault indication.
- Included in scope of delivery for adapter plate for recessed-mounted box.
- Control cable to unit LiYY 7x0.34 mm².
- Voltage supply by WS / WR units.

Article	Art. No.
RLS 1 WR	0157.0809

Features

U _{nom}	12 V
Material	Synthetic material
Width	80 mm
Height	80 mm
Depth	35 mm

**Room air control
RLS D1 WR**



- Optional digital control as an accessory for the WS 170 R../WS 170 L../WS 170 KR../WS 170 KL.. and WR 600 ventilation units.
- Control and power supply through a 2-core bus cable (Opentherm).
- Digital display of the ventilation level, the selected time programme, the room temperature or time, summer function, filter change message and fault message.
- 2 time programmes (week programme). Winter and summer time switch over.
- Rotary switch and inching button for selecting operating mode (on/off, manual selection of performance levels, P1 or P2 time programme, vacation programme, reset, filter change).
- Summer function for switching off the supply air fans.
- Shielded control cable to unit, e.g. LiYCY 2 x 0.75 mm².

Article	Art. No.
RLS D1 WR	0157.0828

Features

U _{nom}	24 V
Degree of protection	IP 20
Material	Synthetic material
Colour	Pure white, similar to RAL 9010
Type of installation	Surface-mounted
Width	145 mm
Height	98 mm
Depth	31 mm

**Room air control
RLS T1 WS**



- Graphic colour TFT display ("touch screen") with user-friendly intuitive menu structure.
- Optional as an accessory for central ventilation units WS 160 Flat, WS 170 KBR../WS 170 KBL.., WR 310/WR 410, WS 320 and WS 470.
- Setting time programs, operating modes, ventilation levels, temperatures etc.
- Amongst other things includes integrated NTC room temperature sensor, mini USB port and 4-wire bus connection (RS 485 includes power supply).
- Display resolution: 480 x 272 pixels (screen diagonal 4.3").

Article	Art. No.
RLS T1 WS	0157.0835

Features

U _{nom}	230 V
Material	Synthetic material
Synthetic material definition	PVC-free polystyrene
Type of installation	Surface-mounted
Width	127 mm
Height	93 mm

**Room air control
RLS 2 F**



- Controller for WS 150 centralised ventilation unit.
- Manual or automatic operation can be selected.
- The 3 switching steps are manually set: Base load, Normal, Full-load and Off.
- Base and normal load switching steps are set automatically by means of a mechanical timer.
- Programming of times for the switching steps in the daily program (24 hours, minimum switching time: 15 minutes) or in the weekly program (7 days, minimum switching time: 2 hours).
- The 3 switching steps are set on a low voltage basis (0.1 A at a maximum of 150 V AC).
- With LED display for the full load switching step.
- Time-controlled filter change display, adjustable from 2 months to 6 months. LED display.
- Control cable to unit, e.g. LiYY 4 x 0.5 mm².

Article	Art. No.
RLS 2 F	0157.0806

Features

U _{nom}	230 V
Degree of protection	IP 20
Maximum load (inductive load)	3 A
Material	Synthetic material
Colour	Pure white, similar to RAL 9010
Type of installation	Surface-mounted
Width	150 mm
Height	90 mm
Depth	36 mm

**Room air control
RLS 3**

Article	Art. No.
RLS 3	0157.0831

- Three-step room air control for ER 100 D exhaust air fan, ZEG 2000 P exhaust air unit, WS 150 centralised ventilation unit and HDR EC duct fan.
- 3 switching steps: Base load, Normal, Full-load (rotary knob).
- With separate, 2-pole on/off switch (rocker switch).
- Both switches in joint double frame.

Features

U _{nom}	230 V
Degree of protection	IP 30
Maximum load	10 A
Material	Synthetic material
Type of installation	Recessed-mounted
Width	150 mm
Height	80 mm
Depth	32 mm

**Radio switch
DS RC**

Article	Art. No.
DS RC	0157.0832



- EnOcean radio switch.
- The radio switch can be used individually with the ECA ... ipro RC/RCH, ER 100 RC fans or the MAICOsmart system.
- The radio switch can also be used in combination with the EnOcean plug-in module E-SM in order to control the WS 160 Flat, WS 170 KBR../WS 170 KBL..., WS 320/470 and WR 310/410 centralised ventilation units using EnOcean.
- For redevelopments and retrofit installations – no painting or wallpapering.
- Tiles don't need to be removed or renewed.
- Application wherever no control cable can be installed.
- Radio switch can be used on the move.
- Radio switch requires no batteries.
- Radio switch can be screwed on or attached to a glass surface.
- Simple transmitter teaching-in saves on time-consuming programming.

Features

Battery	not required
Degree of protection	IP 20
Material	Synthetic material
Colour	Pure white, similar to RAL 9010
Type of installation	Surface-mounted
Installation site	Wall
Mains cable	not required
Minimum ambient temperature	-25 °C
Max. ambient temperature	65 °C
Width	83 mm
Height	83 mm
Depth	16 mm
Transmission range in the building	30 m
Radio frequency	868.3 MHz

**Air quality controller
EAQ 10/2**

Article	Art. No.
EAQ 10/2	0157.0834

- VOC sensor for controlling ventilation unit depending on the air quality.
- With integrated air quality sensor for measuring the concentration of various gases and odours (e.g. carbon monoxide, methane, hydrogen, alcohol, tobacco smoke).
- Metal oxide sensor with automatic calibration.
- Only for connection to the heat recovery units WS 170 R../WS 170 L., WS 170 KR../WS 170 KL.. and WR 600.

Safety instructions

- EAQ 10/2 should not be used in security applications.

Features

U _{nom}	12 V - 25 V AC or 12 V - 36 V DC
Output signal	0 V - 10 V
Degree of protection	IP 30
Housing material	Synthetic material
Colour	Pure white, similar to RAL 9010
Type of installation	Surface-mounted
Installation site	Wall
Sensor measurement range	800/1,200 ppm/CO ₂ equivalent
Width	72 mm
Height	72 mm
Depth	27 mm

Air quality controller for central ventilation units



Air quality controller EAQ 10/3



Article	Art. No.
EAQ 10/3	0157.0829

- Sensor for controlling a ventilation unit or fan depending on the air quality.
- With integrated air quality sensor for measuring the concentration of various gases and odours (e.g. carbon monoxide, methane, hydrogen, alcohol, tobacco smoke).
- Metal oxide sensor with automatic calibration, takes 2 min. to warm up.
- With integrated potential-free contact (VOC and humidity).
- With potential-free relay (n/o contact) with max. 36 VDC / 0.5 A.
- Setting range of relay: VOC: 800 - 1800 ppm (approx. 1300 ppm when delivered), rel. humidity: 30 - 70 % r.h. (approx. 50 % r.h. when delivered).
- 0 - 10 volt output.
- For connecting to WS 170 KBR./ WS 170 KBL., WR 310/WR 410, WS 320 and WS 470 units.

Safety instructions

- EAQ 10/3 should not be used in security applications.

Features

U_{nom}	12 V - 25 V AC or 12 V - 35 V DC
Output signal	0 V - 10 V
Degree of protection	IP 30
I_{max}	14 mA (at 24 V, I_{max} Relay 0.5 A 36 VAC/VDC)
Maximum load	0.5 A
Housing material	Synthetic material
Colour	Pure white, similar to RAL 9010
Ambient temperature	0 °C up to 50 °C
Relative humidity measurement range	5 % up to 95 %
Electrical plug-type connection	Plug with screw terminals for 0.25... 1.5 mm ²
Type of installation	Surface-mounted
Installation site	Wall
Sensor measurement range	450 ppm / 2,000 ppm/ CO ₂ equivalent
VOC switching point	1,300 ppm/ CO ₂ -Equivalent +/- 500 ppm can be set
Humidity switching point	50 %/relative humidity +/- 20 r.h. can be set
Width	80 mm
Height	80 mm
Depth	25 mm

**EnOcean plug-in module
E-SM**

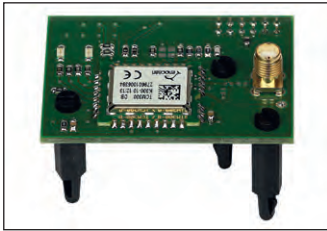

Article **Art. No.**
E-SM **0092.0556**

- The communication module allows the ventilation unit to be controlled with the EnOcean wireless standard.
 - Once the plug-in module has been fitted on the basic PCB, wireless sensors and wireless control units for this can be taught in on the control.
 - For WS 160 Flat, WS 170 KBR../WS 170 KBL., WR 310/WR 410, WS 320 and WS 470 centralised ventilation units.
 - The data is transferred in the 868.3 MHz frequency band.
- **Only the following EnOcean Equipment Profiles (EEP) are supported by the E-SM plug-in module:**
 - Humidity temperature | Afriso | EEP A5-04-01
 - Humidity temperature | Thermokon | EEP A5-04-01
 - CO₂ temperature | Afriso | EEP A5-09-08
 - CO₂ temperature | Thermokon | EEP A5-09-04
 - 4-channel wall transmitter | PEHA | EEP F6-02-01

Features

U _{nom}	12 V DC
Width	54 mm
Height	39 mm

**KNX plug-in module
K-SM**

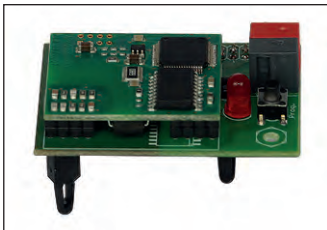

Article **Art. No.**
K-SM **0092.0557**

- The K-SM is fitted on the basic PCB.
- This module then allows the unit control to be integrated in a KNX system (e.g. building control technology).
- For WS 160 Flat, WS 170 KBR../WS 170 KBL., WR 310/WR 410, WS 320 and WS 470 centralised ventilation units.

Features

U _{nom}	12 V DC
Width	54 mm
Height	39 mm

**Additional circuit board
ZP 1**

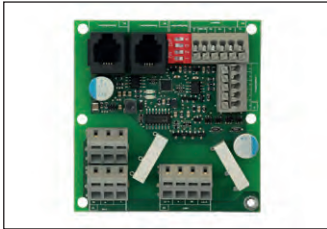

Article **Art. No.**
ZP 1 **0092.0554**

- The ZP 1 additional circuit board is used to control optional components, e.g.
 - to control a 3-way shutter for air-earth heat exchangers
 - to control a controlled pump for a brine earth heat exchanger
 - to control an air shutter for zone control
 - used as a switching contact for external postheating register
- Communication between the basic PCB and additional board ZP 1 is established via the RJ 12 modular cable supplied.
- The desired function can be selected via the Dip switch on the ZP 1.
- For WS 160 Flat, WS 170 KBR../WS 170 KBL., WR 310/WR 410, WS 320 and WS 470 centralised ventilation units.

**Additional circuit board
ZP 2**

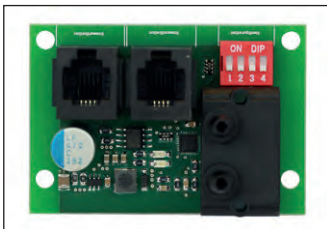

Article **Art. No.**
ZP 2 **0092.0555**

- The ZP 2 additional circuit board is used to control optional components, e.g.
 - to realise the very useful function of pressure consistency for the DC fans
 - for differential pressure-controlled filter monitoring.
- Communication between the basic PCB and additional board ZP 2 is established via the RJ 12 modular cable supplied.
- The desired function can be selected via the Dip switch on the ZP 2.
- With differential pressure controller integrated on the circuit board.
- The pressure tubings are included in the scope of delivery.
- For WS 160 Flat, WS 170 KBR../WS 170 KBL., WR 310/WR 410, WS 320 and WS 470 centralised ventilation units.

**MAICOTherm MT Thermally insulated ventilation duct system
for outside and outgoing air, supply and exhaust air**

DN 125

Ventilation duct, thermally insulated

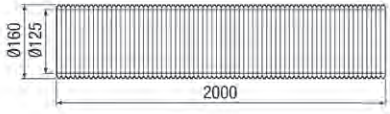
	MT-R125	0059.0981	Thermally insulated and sound-absorbing ventilation duct, heat coefficient 0.040 W/m*K at 40 °C, length 2 m, DN 125	Dimensions [mm]
				

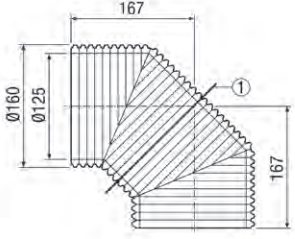

Ventilation elbow, thermally insulated

	MT-B125 90/45	0059.0983	Thermally insulated ventilation duct elbow, 90°, can be separated into 2 x 45°, DN 125	Dimensions [mm]
				
				① Separating line for 45° elbow

Ventilation duct connector

	MT-V125	0059.0985	Ventilation duct connector for connecting MT ducts/elbows together, DN 125	
---	---------	-----------	--	--

Ventilation duct coupling

	MT-Ü125	0059.0986	Ventilation duct coupling, symmetrical, from MT ducts to ventilation unit connection sockets and folded spiral-seams duct, DN 125	
	MT-Üa125	0059.0987	Ventilation duct coupling, asymmetrical, from MT ducts to ventilation unit sockets and folded spiral-seams duct, DN 125	

Mounting clamp

	MT-LS125	0018.0065	Mounting clamp for MT ducts DN 125, with threaded sleeve M8	
--	----------	-----------	---	--

DN 160
Ventilation duct, thermally insulated

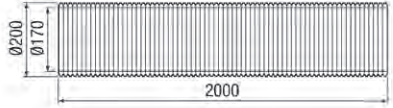
	MT-R160	0059.0982	Thermally insulated and sound-absorbing ventilation duct, heat coefficient 0.040 W/m ² *K at 40 °C, length 2 m, DN 160	Dimensions [mm]
				

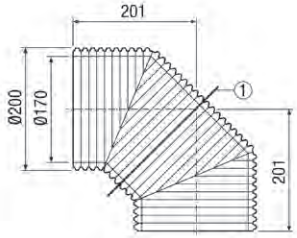

Ventilation elbow, thermally insulated

	MT-B160 90/45	0059.0984	Thermally insulated ventilation duct elbow, 90°, can be separated into 2 x 45°, DN 160	Dimensions [mm]
				
				① Separating line for 45° elbow

Ventilation duct connector

	MT-V160	0059.0988	Ventilation duct connector for connecting MT ducts/elbows together, DN 160	
---	---------	-----------	--	--

Ventilation duct coupling

	MT-Ü160/150	0059.0990	Ventilation duct coupling, symmetrical, from MT ducts to ventilation units with sockets or folded spiral-seams duct, DN 160 or DN 150	
	MT-Ü180	0059.0989	Ventilation duct coupling, symmetrical, from MT ducts to ventilation units with sockets or folded spiral-seams duct, DN 180	

Mounting clamp

	MT-LS160	0018.0066	Mounting clamp for MT ducts DN 160, with threaded sleeve M8	
---	----------	-----------	---	--

Thermally insulated long pipe elbow ABLS 160



Article	Art. No.
ABLS 160	0058.0048

- 90° long pipe elbow with particularly good thermal insulation for heat recovery units with connection diameter of 160 mm.
- Highly beneficial and space-saving when fitted near ventilation unit connections in installation locations offering little space.
- Suited to universal use and for connecting a wide range of ventilation duct materials.
- Alternative to the folded spiral-seams duct design with complex, retrofitted thermal insulation.
- High functionality and flexibility and quick and easy to install.
- The long pipe elbow is easily cut to length using a Stanley knife or hand-held hacksaw thanks to the integrated recessed guide grooves.

Dimensions [mm]

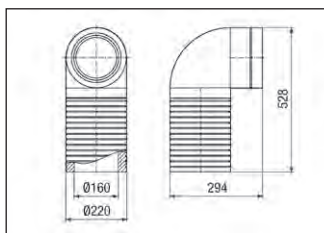

Pressure losses

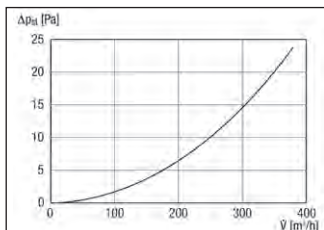

Features

Nominal size	160 mm
Max. volumetric flow	470 m³/h
Material	EPP foam
Colour	Black
Heat coefficient	0.040 W/m²K
Ambient temperature	0 °C up to 40 °C
Airstream temperature	-20 °C up to 60 °C
Air direction	Ventilation and air extraction
External diameter	220 mm
Wall thickness	30 mm

Outside air wall connection KW-AL



Article	Art. No.	Nominal size mm	Colour
KW-AL 12E	0152.0073	125	Stainless steel, brushed
KW-AL 12W	0152.0074	125	Pure white, similar to RAL 9010
KW-AL 16E	0152.0077	160	Stainless steel, brushed
KW-AL 16W	0152.0078	160	Pure white, similar to RAL 9010
KW-AL 20E	0152.0081	200	Stainless steel, brushed
KW-AL 20W	0152.0082	200	Pure white, similar to RAL 9010

- The attractive stainless steel outside air wall supports are fitted on the outside wall of a building and are intended for outside air intake.
- The outside air is drawn in at the bottom.
- An outside air cowl with bird protection grille is included in the scope of delivery.

Dimensions [mm]

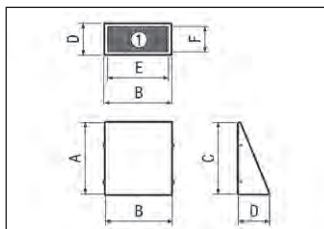

① View from below - outside air intake

Article	A	B	C	D	E	F
	mm	mm	mm	mm	mm	mm
KW-AL 12E	203	172	203	88	148	65
KW-AL 12W	203	172	203	88	148	65
KW-AL 16E	232	228	232	100	203	75
KW-AL 16W	232	228	232	100	203	75
KW-AL 20E	292	280	292	126	226	102
KW-AL 20W	292	280	292	126	226	102

Common features

Material	Stainless steel (V2A)
Installation site	Outside wall
Air direction	Ventilation

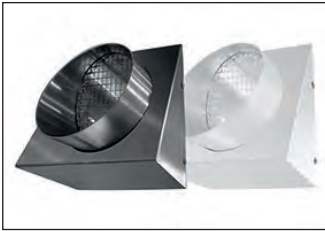
**Outgoing air wall connection
KW-FL**

Article	Art. No.	Nominal size	Colour
		mm	
KW-FL 12E	0152.0075	125	Stainless steel, brushed
KW-FL 12W	0152.0076	125	Pure white, similar to RAL 9010
KW-FL 16E	0152.0079	160	Stainless steel, brushed
KW-FL 16W	0152.0080	160	Pure white, similar to RAL 9010
KW-FL 20E	0152.0083	200	Stainless steel, brushed
KW-FL 20W	0152.0084	200	Pure white, similar to RAL 9010

- The attractive stainless steel outgoing air wall supports are fitted on the outside wall of a building and are intended for blowing out outgoing air.
- The outgoing air is blown out to the front.
- An outgoing air cowl with condensate drip edge and bird protection grille is included in the scope of delivery.

Dimensions [mm]

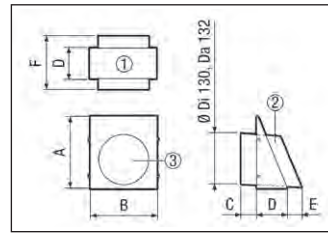

- ① View from below
 ② Side view (outgoing air socket)
 ③ Front view - outgoing air socket

Article	A	B	C	D	E	F
	mm	mm	mm	mm	mm	mm
KW-FL 12E	203	172	50	88	32	170
KW-FL 12W	203	172	50	88	32	170
KW-FL 16E	232	220	45	100	40	185
KW-FL 16W	232	220	45	100	40	185
KW-FL 20E	292	277	40	126	50	215
KW-FL 20W	292	277	40	126	50	215

Common features

Material	Stainless steel (V2A)
Installation site	Outside wall
Air direction	Air extraction

**Combi-wall connections
KWH**

Article	Art. No.	Model	Nominal size
			mm
KWH 12 L	0152.0059	Connections on the left	125
KWH 12 R	0152.0058	Connections on the right	125
KWH 16 L	0152.0061	Connections on the left	160
KWH 16 R	0152.0060	Connections on the right	160
KWH 20 L	0152.0063	Connections on the left	200
KWH 20 R	0152.0062	Connections on the right	200

- The design combi-wall-connection contains outside air and outgoing air sockets in one housing.
- The combi-wall-connection is available as a left-hand or right-hand version.
- This facilitates the laying of ducts in the building between ventilation unit and combi-wall-connection, without crossover.
- Particularly suitable for single family-unit and terraced houses.
- Outside air is sucked in below and the outgoing air is expelled forwards. This minimises the mixing of the two air flows.
- The outgoing air duct connection is inclined a long way to the outside. This disperses the resulting outgoing air condensation.
- Simple installation - consists of two main components:
 - Protective cover
 - Facade part
- The facade fixing points are concealed by the protective cover.
- In locations exposed to the wind or from the second floor upwards, additional measures must be taken to avoid ingress of water through wind pressure or e.g. driving rain at the outgoing air socket.

Dimensions [mm]

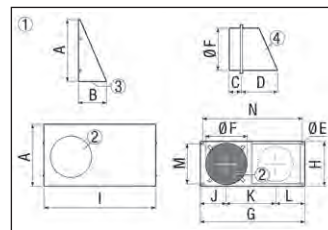

- ① Illustration for right-hand models. The dimensions for the left-hand models are simply mirrored.
 ② Outgoing air
 ③ Outside air
 ④ Inclined connections

Article	A	B	C	D	E	F	G	H	I	J	K	L	M	N
	mm	mm	mm	mm	mm	mm	mm	mm	mm	mm	mm	mm	mm	mm
KWH 12 L	204	88	50	120	6.5	130	352	160	355	78	171	103	141	333
KWH 12 R	204	88	50	120	6.5	130	352	160	355	78	171	103	141	333
KWH 16 L	232	100	50	150	5.5	170	412	185	415	111	190	111	166	393
KWH 16 R	232	100	50	150	5.5	170	412	185	415	111	190	111	166	393
KWH 20 L	282	122	60	160	6.5	215	497	240	500	121	241	135	221	478
KWH 20 R	282	122	60	160	6.5	215	497	240	500	121	241	135	221	478

Common features

Material	Stainless steel (V2A)
Installation site	Outside wall
Air direction	Ventilation and air extraction

EW brine earth heat exchanger

Brine-air heat exchanger EW-K 225



- Brine-air heat exchanger for transferring the warmth from the brine to the outside air.
- Protects the heat exchanger of the ventilation unit from freezing up in the winter (up to -15 °C outside air temperature).
- Cools the outside air in the summer.
- Condensation drain with 3/4" connection below.
- The connection between the register and the PE duct is done by the customer.

Article	Art. No.	Nominal size mm
EW-K 225	0192.0520	224

Dimensions [mm]

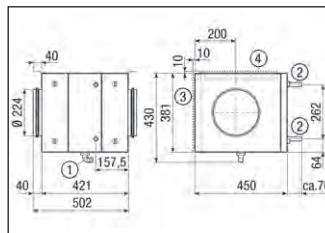

- ① Condensation drain, 3/4"
- ② Brine connection, Ø 18 mm
- ③ Wall mounting bracket
- ④ Ceiling mounting bracket

Characteristic curve

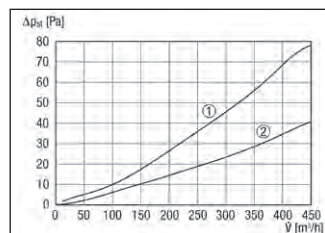

- ① With filter
- ② Without filter

Features

Max. volumetric flow	450 m³/h
Thermal insulation	30 mm
Filter class	G4

Brine pump controller EW-S



- Automatically controls summer and winter operation.
- No seasonal operation required.
- With fault display.
- Switches the pump on at regular intervals, to avoid sticking.
- With predefined factory settings.
- With 2 temperature sensors for outside air temperature before and after the water-air heat exchanger.

Article	Art. No.
EW-S	0157.0203

Features

Width	160 mm
Height	110 mm
Depth	60 mm

Accessories set EW-Z



- Packing unit includes:
- Ready-made pump group:
 - Housing made from EPP.
 - Circulation pump: Wilo ST 15/6 eco3.
 - Ball cocks.
 - Pressure barometer.
 - Expansion tank membrane.
 - Four coupling pieces 32 mm x 1" internal thread.
 - 0.5 m EW hose.

Article	Art. No.
EW-Z	0092.0488

**Pressure duct
EW-D**



- PE high-pressure duct for EW brine geothermal heat exchanger.
- Sufficient for approx. 200 m³/h volumetric flow.

Features

Max. operating pressure	12.5 bar
External diameter	32 mm
Wall thickness	2.9 mm
Packing unit	100 m

Article	Art. No.
EW-D	0059.0200

**Glycosol N
EW-G**



- Heat carrying medium for transferring soil warmth to the outside air.
- 20 litre canister with 100 % Glykosol, sufficient for 100 m EW-D pressure duct at approx. 200 m³/h volumetric flow.
- 25 % Glykosol-water mixture in the duct circuit.
- 1 canister is enough to fill the circuit up completely.

Features

Width	300 mm
Height	250 mm
Depth	380 mm

Article	Art. No.
EW-G	0331.0011

**Air filter, replacement
EW-F**





- Replacement air filter for EW-K 225 brine-air heat exchanger.

Features

Filter class	G4
Material	Synthetic
Max. ambient temperature	50 °C
Width	375 mm
Height	268 mm
Depth	15 mm
Packing unit	2 pieces

Article	Art. No.
EW-F	0093.1231

DN 63
Distributor

	MF-V63	0059.0970	Air distributor made of sound-insulating plastic, with service opening, for 8 x MF-F63 flexible ducts, DN 125 feed duct, width x height x depth: 435 x 150 x 270 mm
	MF-BV63-125-8	0018.0525	Air distributor made of sheet steel, single row, for 8 x MF-F63 flexible ducts, DN 125 feed duct, width x height x depth: 650 x 150 x 450 mm
	MF-BV63-160-14	0018.0526	Air distributor made of sheet steel, double row, for 14 x MF-F63 flexible ducts, DN 160 feed duct, width x height x depth: 650 x 200 x 500 mm

Flexible duct

	MF-F63	0055.0097	Flexible PE-HD duct, length 50 m, external diameter 63 mm, max. 20 m ³ /h, bending radius \geq 150 mm
--	--------	-----------	--

Sealing rings

	MF-FDR63	0175.0261	Sealing rings for connecting MF-F63 with other system components, PU 10 pcs.
--	----------	-----------	--

90° sheet metal elbow

	MF-B63	0018.0068	90° sheet metal segment elbow for MF-F63 flexible steel duct
--	--------	-----------	--

Insertion sleeve

	MF-FSM63	0059.0973	Insertion sleeve for connecting MF-F63 flexible ducts
--	----------	-----------	---





Reducer

	MF-RZ75/63	0018.0072	Sheet metal reducer for MF-F75 flexible steel duct to MF-F63
---	------------	-----------	--

Valve adaptor

	MF-A63	0059.0965	Adaptor for the straight coupling of MF-F63 flexible duct onto DN 100 valve
--	--------	-----------	---

DN 63
Bracket

	MF-WLF100/63/63	0018.0071	Bracket for 90° coupling of 2 MF-F63 flexible ducts onto DN 100 valve, 70 mm high, connector length 300 mm
	MF-W100 80/150	0018.0494	Bracket for 90° coupling of MF-WE63 slide-in adaptor onto DN 100 valve, 80 mm high, connector length 35 mm
	MF-WL100 80/150	0018.0495	Bracket for 90° coupling of MF-WE63 slide-in adaptor onto DN 100 valve, 80 mm high, connector length 310 mm
	MF-WL125 80/150	0018.0499	Bracket for 90° coupling of MF-WE63 slide-in adaptor onto DN 125 valve, 80 mm high, connector length 310 mm

Slide-in adaptor

	MF-WE63	0059.0966	Slide-in adapter for connection of 2 MF-F63 flexible ducts to MF-W/-WL.. bracket 80/150, incl. 1 sealing plug
--	---------	-----------	---

Floor / wall outlet

	MF-FBWA 63	0152.0057	Floor and wall outlet for MAICOFlex ventilation duct system for connecting 2 MF-F63 flexible ducts
---	------------	-----------	--

Mounting clamp

	MF-S63	0018.0471	Mounting clamp for MF-F63, with threaded sleeve M8/M10
---	--------	-----------	--





End plugs

	MF-FST63	0059.0976	End plugs for sealing MF-F63 flexible steel ducts, PU: 10 pieces
---	----------	-----------	--

Cleaning kit

	MF-R63	0058.0011	Cleaning set for MF-F63 flexible duct
---	--------	-----------	---------------------------------------

DN 75
Distributor

	MF-V75	0059.0969	Air distributor made of sound-insulating plastic, with service opening, for 4 x MF-F75 flexible ducts, DN 125 feed duct, width x height x depth: 435 x 150 x 270 mm
	MF-V75-8	0059.0980	Air distributor made of sound-insulating plastic, with 2 service openings, for 8 x MF-F75 flexible ducts, DN 160 feed duct, width x height x depth: 710 x 185 x 350 mm
	MF-BV75-125-6	0018.0527	Air distributor made of sheet steel, single row, for 6 x MF-F75 flexible ducts, DN 125 feed duct, width x height x depth: 650 x 150 x 450 mm
	MF-BV75-160-12	0018.0528	Air distributor made of sheet steel, double row, for 12 x MF-F75 flexible ducts, DN 160 feed duct, width x height x depth: 650 x 200 x 500 mm

Flexible duct

	MF-F75	0055.0096	Flexible PE-HD duct, length 50 m, external diameter 75 mm, max. 30 m ³ /h, —bending radius ≥ 150 mm
--	--------	-----------	--

Sealing rings

	MF-FDR75	0175.0262	Sealing rings for connecting MF-F75 with other system components, PU 10 pcs.
--	----------	-----------	--



90° sheet metal elbow

	MF-B75	0018.0067	90° sheet metal elbow for MF-F75 flexible steel duct
--	--------	-----------	--

Insertion sleeve

	MF-FSM75	0059.0974	Insertion sleeve for connecting MF-F75 flexible ducts
--	----------	-----------	---





Reducer

	MF-RZ75/63	0018.0072	Sheet metal reducer for MF-F75 flexible steel duct to MF-F63
	MF-RZ90/75	0018.0073	Sheet metal reducer for MF-F90 flexible steel duct to MF-F75

Valve adaptor

	MF-A75	0059.0964	Adaptor for the straight coupling of MF-F75 flexible duct onto DN 100 valve
--	--------	-----------	---

DN 75
Bracket

	MF-W150 80/200	0018.0496	Bracket for 90° coupling of MF-WE75 slide-in adaptor onto DN 150 valve, 80 mm high, connector length 310 mm
	MF-WL100 80/200	0018.0530	Bracket for 90° coupling of MF-WE75 slide-in adaptor onto DN 100 valve, 80 mm high, connector length 310 mm
	MF-WL125 80/200	0018.0531	Bracket for 90° coupling of MF-WE75 slide-in adaptor onto DN 125 valve, 80 mm high, connector length 310 mm
	MF-WL150 80/200	0018.0497	Bracket for 90° coupling of MF-WE75 slide-in adaptor onto DN 150 valve, 80 mm high, connector length 310 mm

Slide-in adaptor

	MF-WE75	0059.0972	Slide-in adapter for connection of 2 MF-F75 flexible ducts to MF-W/-WL.. 80/200 bracket, incl. 1 sealing plug
--	---------	-----------	---

Floor / wall outlet

	MF-FBWA 75	0152.0066	Floor and wall outlet for MAICOFlex ventilation duct system for connecting 2 MF-F 75 flexible ducts
---	------------	-----------	---

Mounting clamp

	MF-S75	0018.0470	Mounting clamp for MF-F75, with threaded sleeve M8/M10
---	--------	-----------	--

End plugs

	MF-FST75	0059.0977	End plugs for sealing MF-F75 flexible steel ducts, PU: 10 pieces
---	----------	-----------	--





Cleaning kit

	MF-R75	0058.0012	Cleaning set for MF-F75 flexible duct
---	--------	-----------	---------------------------------------

MAICOFlex MF flexible round ventilation duct system

DN 90

Distributor

	MF-V90	0059.0968	Air distributor made of sound-insulating plastic, with service opening, for 4 x MF-F90 flexible ducts, DN 125 feed duct, width x height x depth: 435 x 150 x 270 mm
	MF-VK90-7	0059.0994	Compact air distributor made of sound-insulating plastic, two service openings, for 7 x MF-F90 flexible duct, DN 125 feed duct with SVR 125 plug connector or DN 160 feed duct with folded spiral-seams duct, width x height x depth: 300 x 490 x 220 mm
	MF-V90-8	0059.0979	Air distributor made of sound-insulating plastic, with 2 service openings, for 8 x MF-F90 flexible ducts, DN 160 feed duct, width x height x depth: 710 x 185 x 350 mm
	MF-BV90-125-5	0018.0608	Air distributor made of sheet steel, single row, for 5 x MF-F90 flexible ducts, DN 125 feed duct, width x height x depth: 650 x 150 x 450 mm

Flexible duct

	MF-F90	0055.0095	Flexible PE-HD duct, length 50 m, external diameter 90 mm, max. 50 m ³ /h, bending radius ≥ 300 mm
---	--------	-----------	---

Sealing rings

	MF-FDR90	0175.0263	Sealing rings for connecting MF-F90 with other system components, PU 10 pcs.
---	----------	-----------	--

90° sheet metal elbow

	MF-B90	0018.0055	90° sheet metal segment elbow for MF-F90 flexible steel duct
--	--------	-----------	--

Insertion sleeve

	MF-FSM90	0059.0975	Insertion sleeve for connecting MF-F90 flexible ducts
--	----------	-----------	---



Reducer

	MF-RZ90/75	0018.0073	Sheet metal reducer for MF-F90 flexible steel duct to MF-F75
---	------------	-----------	--

DN 90
Valve adaptor

	MF-A90	0059.0963	Adaptor for the straight coupling of MF-F90 flexible duct onto DN 100 valve
---	--------	-----------	---

Bracket

	MF-WLF100/90	0018.0607	Bracket for 90° coupling of MF-F90 flexible duct onto DN 100 valve, connector length 300 mm
	MF-WLF125/90	0018.0529	Bracket for 90° coupling of MF-F90 flexible duct onto DN 125 valve, connector length 300 mm

Mounting clamp

	MF-S90	0018.0469	Mounting clamp for MF-F90, with threaded sleeve M8/M10
---	--------	-----------	--

End plugs

	MF-FST90	0059.0978	End plugs for sealing MF-F90 flexible steel ducts, PU: 10 pieces
---	----------	-----------	--

Cleaning kit

	MF-R90	0058.0013	Cleaning set for MF-F90 flexible duct
---	--------	-----------	---------------------------------------

DN 125
Distributor

	FFS-V4	0055.0871	Plastic air distributor with 4 connection options for the flexible oval flat duct and a ventilation duct main connection (DN 125), including a removable service cover with adjustment options, width x height x depth: approx. 675 x 186 x 545 mm, scope of delivery: 3 volumetric flow adjustment elements, 1 black blind cover, 4 O-rings (valve gaskets), 1 horizontal DN 125 air distributor transition piece (FFS-VTHÜ), 1 vertical DN 125 air distributor transition piece (VTVÜ), 2 individual air distributor extensions (FFS-V), 3 gaskets for the distributor extensions, 4 individual duct fixing adapters (FFS-RA), 1 EPS mounting aid (polystyrene)
--	--------	-----------	---

Air distributor extensions

	FFS-V	0055.0873	Extension for the main connection of the air distributor to the ventilation riser branch, width x height x depth: approx. 229 x 57 x 100 mm, scope of delivery: 4 air distributor extensions, 4 sealing rings; a maximum of 4 additional air distributor extensions may be mounted per air distributor
--	-------	-----------	--



Air distributor cover

	FFS-VD	0055.0872	Service cover consisting of stainless steel to be fitted in the floor enabling access to the air distributor; width x height x depth: approx. 308 x 6 x 308 mm, scope of delivery 1 air distributor cover, 4 angle tracks
--	--------	-----------	---

Flexible flat duct

	FFS-R52	0055.0870	Flexible plastic oval flat duct with internal duct, maximum volumetric flow 45 m ³ /h, width x height: approx. 132 x 52 mm, length 20 m
--	---------	-----------	--

Flat duct elbows

	FFS-BV	0055.0877	Plastic channel elbow 90°, vertical model with connection option for flexible flat duct, width x height x depth: approx. 207 x 98 x 98 mm, scope of delivery: 1 channel elbow, 2 individual duct fixing adapters (FFS-RA)
	FFS-BH90	0055.0876	Plastic channel elbow 90°, flat model with connection option for flexible flat duct, width x height x depth: approx. 214 x 60 x 175 mm, scope of delivery: 1 channel elbow, 2 individual duct fixing adapters (FFS-RA)
	FFS-BH45	0055.0878	Plastic channel elbow 45°, flat model with connection option for flexible flat duct, width x height x depth: approx. 206 x 60 x 165 mm, scope of delivery: 1 channel elbow and 2 individual duct fixing adapters (FFS-RA)

Floor outlet

	FFS-BA	0055.0874	Plastic floor outlet for supply air, connecting options for flexible air channel, can be connected on all sides with breakout opening, width x height x depth: approx. 301 x 251 x 210 mm, scope of delivery: 1 floor outlet, 1 individual duct fixing adapter (FFS-RA), 1 EPS mounting aid (polystyrene)
--	--------	-----------	---

Wall/Ceiling outlet

	FFS-WA	0055.0875	Wall and ceiling plastic outlet for supply and exhaust air, connection options for flexible air channel, diameter: 100 mm, width x height x depth: approx. 206 x 319 x 143 mm, scope of delivery: 1 wall/ceiling outlet, 2 individual duct fixing adapters (FFS-RA), 1 blind cover (FFS-D)
--	--------	-----------	--

DN 125
Duct fixing adapters

	FFS-RA	0055.0880	Fixing adapter for connecting two flexible flat ducts with distributors, elbows etc. (click system), width x height x depth: approx. 143 x 59 x 45 mm, PU 5 pieces
---	--------	-----------	--

Sleeves

	FFS-M	0055.0884	Sleeve for connecting two flexible FFS-R52 Flat ducts, width x height x depth: approx. 133 x 52 x 82 mm, PU 5 pieces
---	-------	-----------	--

Connection pieces

	FFS-VS	0055.0882	Connection pieces for example for the connection of 2 channel elbows, width x height x depth: approx. 143 x 59 x 92 mm, PU 5 pieces
---	--------	-----------	---

Transition piece for 180° rotation

	FFS-Ü180	0055.0879	Transition piece for change of direction or 180° rotation of the flexible flat duct, width x height x depth: approx. 143 x 72 x 121 mm, scope of delivery: 1 transition piece, 2 individual duct fixing adapters (FFS-RA)
--	----------	-----------	---

Transition piece flat/round

	FFS-Ü90/75	0055.0887	Transition piece for transition from flexible FFS-R52 flat duct to MF-F75 or MF-F90 MAICOFlex ducts. Scope of delivery: 1 x FFS-Ü90/75 transition piece, 1 x FFS-RF self-locking flange, 1 x adapter, FFS-RA duct fixing adapter, 1 x rubber seal for MF-F90, 1 x rubber seal for MF-F75
---	------------	-----------	--





Mounting clamps

	FFS-S	0055.0883	Mounting clamps for the flexible FFS-R52 flat duct, width x height x depth: approx. 215 x 54 x 25 mm, PU 10 pieces
---	-------	-----------	--





Blind covers

	FFS-D	0055.0881	Blind cover for example for closing unused openings in the air distributor, width x height x depth: approx. 130 x 51 x 45 mm, PU 5 pieces
---	-------	-----------	---



DN 125
Floor grille

	FFS-FGR	0055.0888	Hard-wearing designer floor grille, suitable for the FFS-BA floor outlet. The floor grille made of brushed stainless steel has a modern design with a circular pattern of holes. The mounting frame allows it to be lined up with the surrounding floor covering. It is held in place with clamping pins. Width x height x depth: approx. 340 x 180 x 28 mm, scope of delivery: 1 floor grille, 1 holder, 1 sealing strip
	FFS-FG	0055.0889	Hard-wearing designer floor grille, suitable for the FFS-BA floor outlet. The floor grille made of brushed stainless steel has a modern long-slot design. The mounting frame allows it to be lined up with the surrounding floor covering. It is held in place with clamping pins. Width x height x depth: approx. 340 x 180 x 30 mm, scope of delivery: 1 floor grille, 1 holder, 1 sealing strip
	FFS-FGB	0055.0890	Hard-wearing standard floor grille, suitable for the FFS-BA floor outlet. The floor grille made of brushed stainless steel has a modern design with a circular pattern of holes. It is held in place with clamps that are positioned tight under the floor grille. Width x height x depth: approx. 340 x 180 x 3 mm, scope of delivery: 1 floor grille, 1 sealing strip
	FFS-FGBW	0055.0891	Hard-wearing standard floor grille, suitable for the FFS-BA floor outlet. The floor grille made of white lacquered stainless steel has a modern design with a circular pattern of holes. It is held in place with clamps that are positioned tight under the floor grille. Width x height x depth: approx. 340 x 180 x 3 mm, scope of delivery: 1 floor grille, 1 sealing strip
	FFS-FGE	0055.0902	Hard-wearing standard floor grille, suitable for the FFS-BA floor outlet. The floor grille made of brushed stainless steel has a modern design with a rectangular pattern of holes. It is held in place with clamps that are positioned tight under the floor grille. Width x height x depth: approx. 340 x 180 x 3 mm, scope of delivery: 1 floor grille, 1 sealing strip

Wall/Ceiling grille

	FFS-WG	0055.0892	Designer wall/ceiling grille, suitable for the FFS-WA wall/ceiling outlet. The grille made of brushed stainless steel has a modern long-slot design. It is held in place with clamps, diameter: 150 mm, height: 40 mm, scope of delivery: 1 wall/ceiling grille, 1 regenerable filter
	FFS-WGB	0055.0893	Designer wall/ceiling grille, suitable for the FFS-WA wall/ceiling outlet. The grille made of brushed stainless steel has a modern design with a circular pattern of holes. It is held in place with clamps, diameter: 150 mm, height: 38 mm, scope of delivery: 1 wall/ceiling grille, 1 regenerable filter
	FFS-WGBW	0055.0894	Designer wall/ceiling grille, suitable for the FFS-WA wall/ceiling outlet. The grille made of white painted stainless steel has a modern design with a circular pattern of holes. It is held in place with clamps, diameter: 150 mm, height: 38 mm, scope of delivery: 1 wall/ceiling grille, 1 regenerable filter
	FFS-WGE	0055.0903	Designer wall/ceiling grille, suitable for the FFS-WA wall/ceiling outlet. The grille made of stainless steel has a modern design with an angular pattern of holes. It is held in place with clamps, diameter: 150 mm, height: 38 mm, scope of delivery: 1 wall/ceiling grille, 1 regenerable filter

DN 125
Air distributor transition pieces

	FFS-VTHÜ	0055.0901	Horizontal coupling from the air distributor to the folded spiral-seams duct; this item may be required as spare part
	FFS-VTVÜ	0055.0900	Vertical coupling from the air distributor to the folded spiral-seams duct; this item may be required as spare part

O-ring set for air distributor

	FFS-V4OR	0055.0895	O-rings (valve gaskets) for the FFS-V4 air distributor, PU: 5 pieces, which may be required as spare part
---	----------	-----------	---

Inlet element/cover set for air distributor

	FFS-V4ED	0055.0897	Inlet element/cover set for the FFS-V4 air distributor, scope of delivery: 2 volumetric flow adjustment elements and 2 black blind covers, which may be required as spare parts
---	----------	-----------	---

Sealing ring set for air distributor extension

	FFS - VOR	0055.0896	Sealing ring set for the FFS-V air distributor extension, PU: 3 pieces, which may be required as spare part
---	-----------	-----------	---

Self-locking flanges

	FFS-RF	0055.0898	Self-locking flange for direct connection of the flat duct to shaped elements, width x height x depth: approx. 143 x 57 x 21 mm, PU: 5 pieces; this item may be required as spare part
---	--------	-----------	--

PushPull 45 single-room ventilation unit

Final assembly kits PP 45 K/PP 45 O/PP 45 RC



Article	Art. No.	U _{nom}	Required room air control
V			
PP 45 K	0095.0241	12 V DC	RLS 45 K/ RLS 45 O
PP 45 O	0095.0240	12 V DC	RLS 45 O/ RLS 45 K
PP 45 RC	0095.0242	230 V	DS 45 RC or RLS 45 K with PP 45 EO

Features

- Final assembly kits for PushPull 45 single-room ventilation unit with fan, ceramic heat exchanger, internal cover and two integrated filters (G2 + G3) such that the air is filtered in both directions.
- Models:
 - PP 45 K - with electric shutter.
 - PP 45 O - with manual shutter.
 - PP 45 RC - with radio control and electric shutter.
- To achieve efficient ventilation, we would recommend operating the units in pairs. This is a basic requirement for the PP 45 RC final assembly kit.
- Accessories needed:
 - PP 45 RHK or PP 45 RHL shell sleeve
 - PP 45 AK, PP 45 AE or PP 45 AW external cover for external wall mounting or PP 45 LE soffit element for soffit channel mounting
 - RLS 45 K or RLS 45 O room air control for the PP 45 K and PP 45 O final assembly kits and DS 45 RC radio switch for the PP 45 RC radio unit
 - Up to a maximum of 6 units can be controlled at the same time through an RLS 45 K or RLS 45 O room air control.
 - If using the DS 45 RC radio switch, there is no limit on the number of units provided that they are within range of the radio switches.
- Optional accessories:
 - Wall block PP 45 MB
 - PP 45 LT power unit
 - PP 45 EO EnOcean extension module
 - PP 45 ACT EnOcean actuator
 - PP 45 HYI and PP 45 HY humidity sensor
 - PP 45 CO₂ CO₂ sensor
- PP 45 VOC VOC sensor
- Air filter replacement, PP 45 G2, PP 45 G3 and PP 45 G2P
- The PP 45 K and PP 45 RC unit versions have an electric shutter. If the units are switched off (level 0), the shutter closes automatically. The unit does not consume electricity in the process.
- With the PP 45 O final assembly kit, the shutter is closed manually.
- The PP 45 HYI internal humidity sensor or the PP45 HY, PP 45 CO₂ and PP 45 VOC external sensors can be added to the RLS 45 K and RLS 45 O room air controls. The units therefore attain the A+ energy efficiency class.
- The RLS 45 K and RLS 45 O room air controls and the PP 45 RC radio units with the DS 45 RC radio switch can be operated in 5 ventilation levels of 15/20/30/36/42 m³/h and 3 operating programs (continuous ventilation with heat recovery, cross-ventilation and sensor-controlled automatic mode). In automatic mode, the air volume is continuously adapted to the sensor value.
- With the RLS 45 O room air control, automatic mode is only possible with the connected sensor.
- The RLS 45 K room air control and DS 45 RC radio switch can also perform other functions, such as intermittent ventilation (time-limited intensive ventilation) and sleep function (time-limited shutdown).
- Using the RLS 45 K room air control, exhaust air units (e.g. ECA/ER) can communicate with PushPull units and vice versa. In other words, when an exhaust fan starts up, the PushPull units go into supply air mode to compensate for the partial vacuum produced. Supply air mode is possible with an over-run time of 0.6 or 15 min. The number of connected units is also taken into account.
- When combined with the PP 45 EO EnOcean extension module, the RLS 45 K room air control provides the unique opportunity of linking the wired PP 45 K and PP 45 O units and PP 45 RC radio units with one another. This control combination can therefore be used to install wired units on the ground floor and radio units on the first floor. The entire system is activated at the touch of a button.
- What's more, the RLS 45 K room air control allows the unit to be easily configured using installation software on a PC/laptop (Windows).

Dimensions [mm]

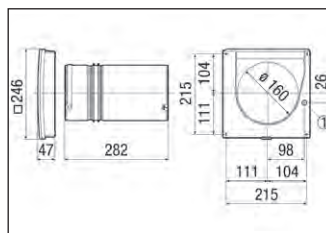

① Cable feedthrough

Common features

Air flow volume	15 / 20 / 30 / 36 / 42 m ³ /h
Maximum power consumption	1.2 / 1.7 / 2.1 / 2.8 / 3.5 W
Degree of protection	IP 00
Filter class	G2/G3
Housing material	PP plastic
Heat exchanger material	Ceramic
Colour	Traffic white, similar to RAL 9016
Installation position	horizontal
Sound pressure level	23 / 28 / 33 / 37 / 40 dB(A) (Distance 1 m, free-field conditions)
Max. degree of heat provision in accordance with DIN EN 13141-8	84.3 %/at reference volumetric flow 30 m ³ /h
Connection diameter	160 mm
Wall thickness	290 mm/500 mm
Energy efficiency class	A+
Wall has to be broken through	162 to 182 mm

**Shell sleeves
PP 45 RHK/PP 45 RHL**

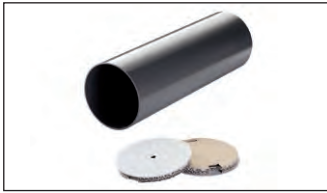

- Accessories needed for the PP 45 K, PP 45 O and PP 45 RC final assembly kits.
- Available in two different lengths: PP 45 RHK, 500 mm in length, and PP 45 RHL, 800 mm in length.
- Scope of delivery: 1 x shell sleeve, 1 x mounting material.

Article	Art. No.	Length mm
PP 45 RHK	0059.0081	500
PP 45 RHL	0059.0082	800

Common features

Nominal size	160 mm
Material	Synthetic material
Installation site	Outside wall
Needed core hole	182 mm

**Insulated wall block
PP 45 MB**

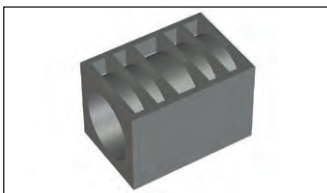

- Insulated wall block as optional accessory for the PP 45 RHK and/or PP 45 RHL shell sleeve.
- Takes the place of the core hole in new builds.
- Depth can be shortened to 300 mm or 240 mm.

Dimensions [mm]

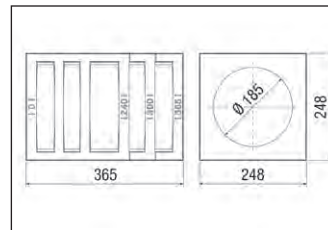

Features

Nominal size	180 mm
Material	Plastic EPP
Installation site	Outside wall
Fire protection	Fire-proof class B1

Article	Art. No.
PP 45 MB	0058.0143

**External cover
PP 45 AK**



- Plastic external cover. Colour: traffic white (similar to RAL 9016).
- With integrated condensation drip edge.
- The grilles are flow-optimised to minimise air disturbance.
- An external cover is needed as an accessory for the PP 45 K, PP 45 O and PP 45 RC final assembly kits.

Dimensions [mm]

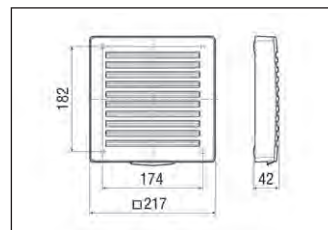

Features

Housing material	Synthetic material
Colour	Traffic white, similar to RAL 9016
Installation site	Outside wall

Article	Art. No.
PP 45 AK	0093.0176

**External cover
PP 45 AE**



- External cover made from brushed stainless steel (V4A).
- With integrated condensation drip edge.
- The flow-optimised hood also has a sound-absorbing insert.
- An external cover is needed as an accessory for the PP 45 K, PP 45 O and PP 45 RC final assembly kits.

Dimensions [mm]

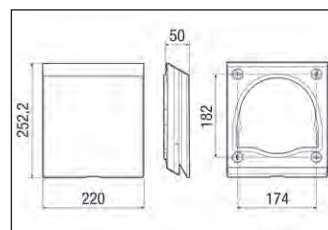

Features

Housing material	Stainless steel, brushed
Colour	Stainless steel, brushed
Installation site	Outside wall

Article	Art. No.
PP 45 AE	0093.0177

**External cover
PP 45 AW**



- Aluminium external cover Anodised, pure white colour (similar to RAL 9010).
- With integrated condensation drip edge.
- The flow-optimised hood also has a sound-absorbing insert.
- An external cover is needed as an accessory for the PP 45 K, PP 45 O and PP 45 RC final assembly kits.

Dimensions [mm]

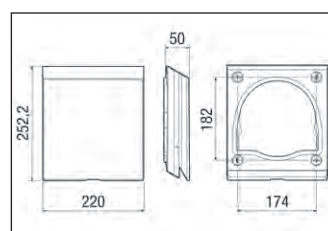

Features

Housing material	Aluminium
Colour	Anodised, pure white, similar to RAL 9010
Installation site	Outside wall

Article	Art. No.
PP 45 AW	0093.0178

PushPull 45 single-room ventilation unit

Soffit element PP 45 LE



- A soffit element is needed as an accessory for the PP 45 K, PP 45 O and PP 45 RC final assembly kits when mounting in the window soffit.
- The external cover of the soffit channel is made from brushed stainless steel.

Article **Art. No.**
PP 45 LE 0093.0179

Dimensions [mm]

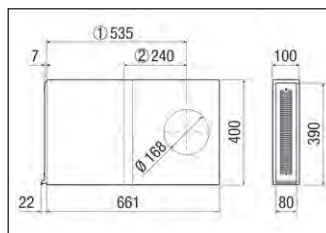

- ① Maximum length
- ② Minimum length

Features

Housing material	Plastic EPP
Material of external cover	Stainless steel
Colour	Stainless steel, brushed
Installation site	Outside wall

Soffit element extension PP 45 LEV



- Soffit element extension as an accessory for PP 45 LE soffit element. The extension serves to extend the soffit channel installation length from 535 mm to 858 mm.

Article **Art. No.**
PP 45 LEV 0093.1483

Dimensions [mm]

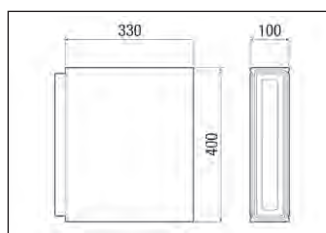

Features

Housing material	Plastic EPP
Colour	Black
Installation site	Outside wall

Sound-absorbing element PP 45 SE

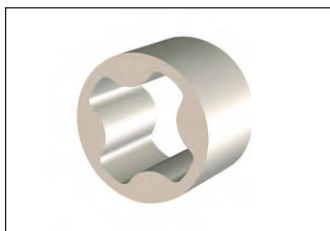

- Sound-absorbing element as optional accessory for PP 45 O, PP 45 K and PP 45 RC final assembly kit.
- Is used to reduce the sound power level and increase the sound insulation level.
- Reduction in sound power level of up to 2 dB(A) with one sound-absorbing element.
- Reduction in sound power level of up to 3.5 dB(A) with two sound-absorbing elements (turned 45°).
- Scope of delivery:
 - 1 x outer ring
 - 1 x inner part
 - The inner part only serves as transport protection and has to be removed before installation in the final assembly kit.

Article **Art. No.**
PP 45 SE 0093.0308

Dimensions [mm]

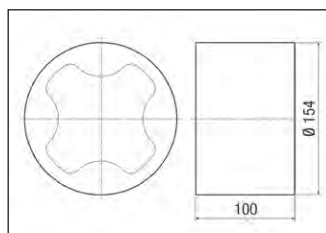

Features

Material	melamine resin
Colour	grey
Installation site	Wall
External diameter	154 mm
Fire protection	Fire-proof class B1

Characteristic curve

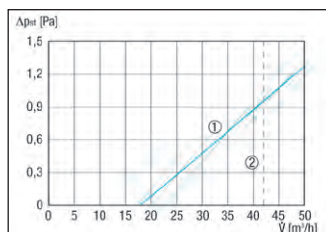

- ① Maximum pressure loss characteristics curve with two PP 45 SE sound-absorbing elements (10 cm), positioned turned 45° to one another
- ② Maximum volumetric flow (42 m³/h) of the PP 45 K, PP 45 O and PP 45 RC final assembly kits

**Room air control
RLS 45 K**

Article **Art. No.**
RLS 45 K **0157.0360**

- The room air control is needed as an accessory for the PP 45 K or PP 45 O final assembly kit.
- For the PP 45 RC final assembly kit, the control can be used as an option in place of the DS 45 RC radio switch. A combination of RLS 45 K with the EnOcean extension module PP 45 EO is then needed.
- Room air control RLS 45 K features the following setting options:
 - 5 ventilation levels with heat recovery: 15 / 20 / 30 / 36 / 42 m³/h
 - Continuous ventilation with heat recovery, cross-ventilation and sensor-controlled auto operating modes.
 - Continuous ventilation with heat recovery operating mode: PushPull mode. The units run in alternation and change direction every 60 s.
- Cross-ventilation operating mode: One unit is permanently in supply air mode and the corresponding unit in exhaust air mode (e.g for cooling during a night in summer).
- In automatic mode, the air volume is adjusted continuously to the sensor value (HY1, HY, CO₂, VOC).
- Time-limited intensive ventilation, time-limited switch-off and safety switch-off.
- Communication with exhaust air units. When the exhaust air units start up, the PP units switch to supply air.
- ModBus.
- Configuration with PC or laptop.
- Up to 6 units can be controlled at the same time through an RLS 45 K room air control.

Features

U _{nom}	230 V
Mains cable	3 x 1.5 mm ²
Material	Synthetic material
Colour	Pure white, similar to RAL 9010
Type of installation	Recessed-mounted
Installation site	Wall
Width	80 mm
Height	80 mm
Depth	49 mm

**Room air control
RLS 45 O**

Article **Art. No.**
RLS 45 O **0157.0359**

- The room air control is needed as an accessory for the PP 45 O or PP 45 K final assembly kit.
- RLS 45 O room air control features the following setting options:
 - 5 ventilation levels with heat recovery: 15 / 20 / 30 / 36 / 42 m³/h
 - Continuous ventilation with heat recovery, cross-ventilation and auto operating modes.
 - Continuous ventilation with heat recovery operating mode: Push Pull mode. The units run in alternation and change direction every 60 s.
- Cross-ventilation operating mode: One unit is permanently in supply air mode and the corresponding unit in exhaust air mode (e.g for cooling during a night in summer).
- In automatic mode, the air volume is adjusted continuously to the sensor value (HY1, HY, CO₂, VOC).
- Up to 6 units can be controlled at the same time through an RLS 45 O room air control.

Features

U _{nom}	230 V
Mains cable	2 x 1.5 mm ²
Material	Synthetic material
Colour	Pure white, similar to RAL 9010
Type of installation	Recessed-mounted
Installation site	Wall
Width	80 mm
Height	80 mm
Depth	49 mm

**Power module
PP 45 LT**

Article **Art. No.**
PP 45 LT **0157.0361**

- Power unit for extending the PushPull system to more than 6 units.
- A further 6 units can be connected per power unit.
- Is connected to the RLS 45 K or RLS 45 O room air control using the RS485 interface.
- The commands of the RLS 45 K or RLS 45 O room air control are forwarded to the connected units by the PP 45 LT.
- A maximum of three power units can be connected per room air control.

Features

U _{nom}	230 V
Mains cable	2 x 1.5 mm ²
Material	Synthetic material
Colour	Pure white, similar to RAL 9010
Type of installation	Recessed-mounted
Installation site	Wall
Width	80 mm
Height	80 mm
Depth	49 mm

PushPull 45 single-room ventilation unit

EnOcean extension module PP 45 EO



Article **Art. No.**
PP 45 EO 0157.0362

- To convert the electric signals to EnOcean radio.
- So that the PP 45 RC units can be controlled.
- Is connected to the RLS 45 K room air control using the RS485 interface.
- A system combination of wired PP 45 K units and PP 45 RC radio devices is thereby possible.
- The PP 45 EO extension module can be used to integrate further EnOcean modules, e.g. radio sensors (H, CO₂).

Features

Material	Synthetic material
Colour	Pure white, similar to RAL 9010
Type of installation	Recessed-mounted
Installation site	Wall
Width	80 mm
Height	80 mm
Depth	49 mm

Radio switch DS 45 RC



Article **Art. No.**
DS 45 RC 0157.0363

- The radio switch is needed as an accessory for the PP 45 RC final assembly kit.
- The DS 45 RC radio switch features the following setting options:
 - 5 ventilation levels with heat recovery: 15 / 20 / 30 / 36 / 42 m³/h.
 - Continuous ventilation with heat recovery, cross-ventilation and auto operating modes.
 - Continuous ventilation with heat recovery operating mode: Push Pull mode. The units run in alternation and change direction every 60 s.
 - Cross-ventilation operating mode: One unit is permanently in supply air mode and the corresponding unit in exhaust air mode (e.g for cooling during a night in summer).
- Automatic mode is only possible with the PP 45 HYI humidity sensor which can be integrated into the unit as an option.
- In automatic mode, the air volume is continuously adapted to the sensor value.
- Time-limited intensive ventilation, time-limited switch-off and safety switch-off.
- The DS 45 RC radio switch can be used to control any number of units provided they are within range.
- Application wherever no control cable can be installed.
- The radio switch requires no batteries.
- The radio switch can be screwed on or attached to a glass surface.

Features

Mains cable	not required
Material	Synthetic material
Colour	Pure white, similar to RAL 9010
Type of installation	Surface-mounted
Installation site	Wall
Width	80 mm
Height	80 mm
Depth	15 mm

EnOcean actuator PP 45 ACT



Article **Art. No.**
PP 45 ACT 0157.1445

- Using the EnOcean actuator, PP 45 RC PushPull radio units can be combined with wired exhaust air units (ECA, ER) to produce one ventilation system.
- The actuator can be used as a normal light switch. At the touch of a button, the wired exhaust air units (ECA, ER) are switched on and at the same time, a radio telegram is sent to the PP 45 RC final assembly kit (master). The PP 45 RC units (master + slave) provide the supply air needed for the exhaust air units.

Features

Mains cable	5 x 1.5 mm ²
Material	Synthetic material
Type of installation	Recessed-mounted
Installation site	Wall
Width	70 mm
Height	70 mm
Depth	40 mm

Humidity sensor PP 45 HYI



Article **Art. No.**
PP 45 HYI 0157.0364

- Integrated humidity sensor for PushPull 45 single-room ventilation unit.
- Can be integrated in the RLS 45 K or RLS 45 O room air control (via plug connection).
- The opening intended for this on the frame must be above the sensor.
- The PP 45 HYI humidity sensor can also be integrated in the PP 45 RC master radio unit (using a plug connection).
- Depending on the sensor value, the air volume of the PushPull units is continuously increased.

Features

Width	15 mm
Height	15 mm
Depth	5 mm

External sensors
PP 45 HY / PP 45 CO₂ /
PP 45 VOC



Article	Art. No.
PP 45 HY	0157.0365
PP 45 CO ₂	0157.0366
PP 45 VOC	0157.0367

- External humidity sensor for PushPull 45 single-room ventilation unit.
- The sensor is connected to the RLS 45 K or RLS 45 O room air control using the RS485 interface.
- This allows the sensor to be located in a different place to the room air control.
- Can be installed in a simple recessed-mounted box.
- A maximum of 3 external sensors can be connected per room air control.
- Depending on the sensor value, the air volume of the PushPull units is continuously increased.

Features

Width	80 mm
Height	80 mm
Depth	49 mm

Air filters, replacement
PP 45 G2/PP 45 G3



Article	Art. No.	Filter class
PP 45 G2	0093.0273	G2
PP 45 G3	0093.0274	G3

- Replacement air filter kit for PushPull 45 single-room ventilation unit.
- The G2 filters are installed on the inside and the G3 filters on the outside.

Article	Width mm	Height mm	Depth mm
PP 45 G2	140	140	10
PP 45 G3	140	140	15

Common features

Packing unit	2 pieces
--------------	----------

Air filter, replacement
PP 45 G2P



Article	Art. No.
PP 45 G2P	0093.1444

- Replacement air filter kit comprising washable filters.

Features

Filter class	G2
Packing unit	10 pieces



Energy efficiency class



WRG 35 single-room ventilation unit



Final assembly kits WRG 35-1-SE/ WRG 35H-SE



Article	Art. No.	Inte- grated hygro- stat	Energy effi- ciency class
WRG 35-1-SE	0082.0235	–	B
WRG 35H-SE	0082.0234	✓	A

Features

- Complete fan unit for WRG 35 single-room ventilation unit with heat recovery, including internal cover and two G4 filters. WRG 35H-SE: With integrated hygrostat.
- Accessories needed:
 - WRG 35-SR shell kit.
 - RLS 5 room air control.
 - Up to a maximum of 9 units can be controlled at the same time through a room air control.
- Up to four RLS 5 room air controls can be connected to one unit. They are networked using a WRG 35-AAD connection distributor and WRG 35-TAK connection cables.
- Suitable for continuous operation. Longer off times are not recommended.

Dimensions [mm]

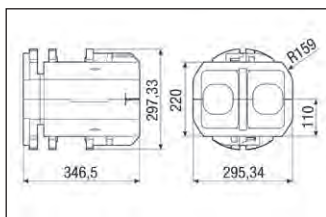

Dimensions of internal cover:
W x H x D: 380 x 380 x 45 mm

Common features

U _{nom}	230 V
f _{nom}	50 Hz
Air flow volume	17 / 30 / 45 / 60 m ³ /h
Power consumption	2 / 4 / 6 / 8 W
I _{max}	0.04 / 0.05 / 0.06 / 0.07 A
Degree of protection	IP X4
Filter class	G4
Housing material	Plastic EPP
Heat exchanger material	Aluminium
Installation site	Wall
Sound pressure level	14 / 25 / 30 / 37 dB(A) (Distance 3 m, Free-field conditions)
Rated max. element normal difference in noise level D _{n,w}	39 dB
Heat recovery	> 70 %
Heat exchanger construction type	Cross flow
Max. ambient temperature	40 °C
Required room air control	RLS 5

Shell kit WRG 35-SR

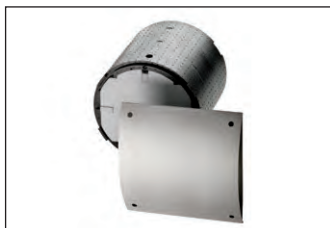

Article	Art. No.
WRG 35-SR	0192.0450

- Scope of delivery: Wall sleeve (3 parts), 2 plaster protective covers and stainless steel external cover with drilling template.
- Is needed as accessory for WRG 35-1-SE and WRG 35H-SE final assembly kits.

Dimensions [mm]

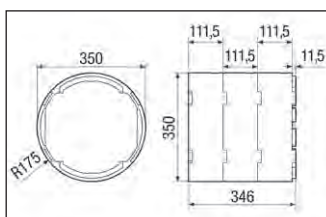

Diameter of core hole 360 mm
Dimensions of external cover:
W x H x D: 370 x 370 x 59 mm

Features

Nominal size	350 mm
Material	Plastic EPP
Installation site	Wall
Max. ambient temperature	40 °C

Extension sleeve WRG 35-VH



Article	Art. No.
WRG 35-VH	0192.0451

- Wall sleeve extension from the WRG 35 single-room ventilation unit.
- Scope of delivery: extension sleeve, 2 separating bridges and condensation hose.

Features

Nominal size	350 mm
Material	Plastic EPP
Installation site	Wall
Max. ambient temperature	40 °C

**Compensating frame
WRG 35-AR**



Article	Art. No.
WRG 35-AR	0192.0454

- Compensating frame for WRG 35 single-room ventilation unit.
- The compensating frame is needed if the wall is thinner than 350 mm and the shell kit (wall sleeve) therefore protrudes too far out of the wall such that the outer cover can no longer be fitted. The outer wall must however be at least 251 mm thick.
- Scope of delivery:
 - 1 x compensating frame (material: V2A)
 - 1 x extension sleeve (material: PVC)
 - 1 x separating bridge (material: EPP)
 - 1 x condensation drain extension (material: EPP)

Dimensions [mm]

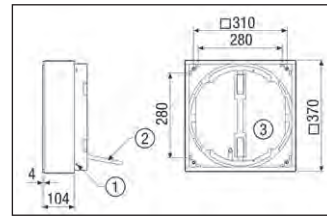

- ① Stainless steel M5 x16 screws
- ② Condensate drain extension
- ③ View on inside

Features

Material	Plastic EPP
Housing material	Stainless steel
Installation site	Wall
Max. ambient temperature	40 °C

**Room air controls
RLS 5**



Article	Art. No.	Type of installation
RLS 5 AP	0157.0845	Surface-mounted
RLS 5 UP	0157.0846	Recessed-mounted

- Room air control for WRG 35 single-room ventilation unit.
- The controller is needed as accessory for the WRG 35-1-SE and WRG 35H-SE final assembly kit.
- Accessories supplied: 5 m connecting duct.
- Up to a maximum of 9 units can be controlled at the same time through an RLS 5 room air control.
- Automatic operation with individually programmable week program.
- Timer function for party operation or standby operation.
- Vacation mode can be programmed.
- Filter change display interval can be set to between 2 and 9 months.
- Operating hours display.

Common features

Degree of protection	IP 00
Material	Synthetic material
Colour	White
Width	80 mm
Height	80 mm
Depth	20 mm

**Connection distributor
WRG 35-AAD**

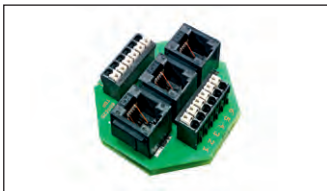

Article	Art. No.
WRG 35-AAD	0092.0501

- Connection distributor for networking several (max. 9) WRG 35 single-room ventilation units or for networking one or more (max. 4) RLS 4-1 or RLS 5 room air control(s).
- The connection distributor is equipped with three RJ-12 bushes.
- Suitable connecting ducts:
 - WRG 35-TAK 5 (5 m)
 - WRG 35-TAK 10 (10 m)

Features

Width	50 mm
Height	50 mm
Depth	20 mm

**Connecting ducts
WRG 35-TAK**



Article	Art. No.	Length m
WRG 35-TAK 5	0092.0502	5
WRG 35-TAK 10	0092.0503	10

- Connection cable with RJ 12 plug at both ends for WRG 35.

**Air filters, replacement
WRG 35-G4/F7**

Article	Art. No.	Packing unit	Filter class
WRG 35-G4	0192.0452	2 pieces	G4
WRG 35-F7	0192.0453	1 piece	F7

- Replacement air filters for WRG 35 single-room ventilation unit.
- Easy filter change.

Article	Width mm	Height mm	Depth mm
WRG 35-G4	175	150	10
WRG 35-F7	175	160	20



B Energy efficiency class WRG-35-SE

A Energy efficiency class WRG 35H-SE

Fans for commercial premises and workplaces



Axial wall-mounted and window fans for small commercial premises

EN / ENR axial wall-mounted fan for small commercial premises

Very easy to clean, modern design
Ventilation and air extraction possible, up to 1,500 m³/h



Page 178

FE 100/1 window installation kit for ECA 100 ipro

For installation in windows and thin walls, up to 92 m³/h
either with external shutter or protection grille

NEW!



Page 23

EVN axial window fan for small commercial premises

With electrical external shutter or pull cord, up to 640 m³/h



Page 180

EV / EVR / EVH axial window fan for small commercial premises

With electrical internal shutter or pull cord, up to 1,425 m³/h



Page 182

Axial high-power fans for air circulation

EC / ECO axial ceiling fan for air circulation

Powerful, up to 18,000 m³/h



Page 184

EZG axial greenhouse fan for air circulation

For suspended installation on roof construction, up to 3,800 m³/h



Page 186



Features

- Housing can be easily removed without tools, for cleaning.
- Pleasantly quiet.
- Clean and fast exchange of existing EN devices thanks to 100 % compatibility with the previous EN and ET devices.
- In the case of existing electrical external shutters with plug connection: Remove the plug and reconnect the individual cables according to the EN/ENR wiring diagrams.
- Maintenance-free fan.

Motor

- Thermal overload protection as standard feature.
- Robust motor.
- Suitable for continuous operation.

Electrical connection

- Electrical connection can be either surface- or recessed-mounted.

Safety instructions

- The fan may be operated only if the protection against accidental contact with the impeller is guaranteed to be in accordance with DIN EN ISO 13857.

Technical data

Article	Art. No.	Air direction	U_{nom}	f_{nom}	Rotating speed	Air flow volume	P_{nom}	I_{max}	T_{max} at I_{max}	Sound power level L_{WA7} dB(A)	Degree of protection IP	Mains cable mm ²	Weight kg
			V	Hz	1/min	m ³ /h	W	A	°C				
EN 20	0081.0307	Air extraction	230	50	1,350	420	30	0.21	40	54	44	3 x 1.5	2.5
ENR 20	0081.0316	Ventilation or air extraction	230	50	1,380	460	42	0.21	40	57	44	5 x 1.5	2.7
EN 25	0081.0308	Air extraction	230	50	1,030	630	39	0.23	40	54	44	3 x 1.5	2.6
ENR 25	0081.0317	Ventilation or air extraction	230	50	1,240	840	48	0.22	40	59	44	5 x 1.5	3.1
EN 31	0081.0309	Air extraction	230	50	1,220	1,500	76	0.33	40	66	44	3 x 1.5	4.6
ENR 31	0081.0318	Ventilation or air extraction	230	50	1,210	1,500	76	0.33	40	66	44	5 x 1.5	4.6

Dimensions [mm]

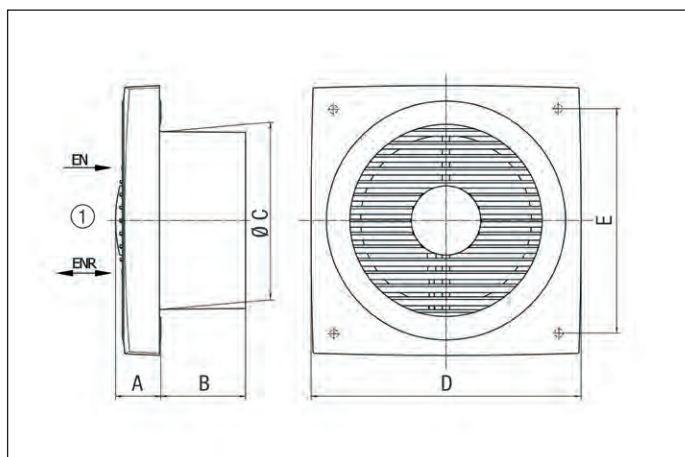

① Inside

Article	A	B	C	D	E
EN 20	55	103	212	320	268
ENR 20	55	103	212	320	268
EN 25	55	103	266	370	315
ENR 25	55	103	266	370	315
EN 31	60	126	320	445	375
ENR 31	60	126	320	445	375

Accessories selection table

	EN 20	ENR 20	EN 25	ENR 25	EN 31	ENR 31	see
Specific accessories							
Dark room attachment	ZDK 25	ZDK 25	ZDK 25	ZDK 25	-	-	P. 179
General accessories							
Shutter	AS 20	-	AS 25	-	AS 30	-	P. 297
Shutter, electric	MK 20	MK 20	MK 25	MK 25	MK 31	MK 31	P. 298
Wall sleeve	WH 20	WH 20	WH 25	WH 25	WH 31	WH 31	P. 179
Extension sleeve	VH 20	VH 20	VH 25	VH 25	VH 31	VH 31	P. 179
Step switch	FS 4	-	FS 4	-	FS 4	-	P. 335
Step switch, reversing switch	-	FS 6	-	FS 6	-	FS 6	P. 335
Reversing switch	-	W 1 WU 1 FS 7	-	W 1 WU 1 FS 7	-	W 1 WU 1 FS 7	P. 334, P. 335
Radio switch	XS 1	XS 1	XS 1	XS 1	XS 1	XS 1	P. 350
Radio receiver	XE 1	XE 1	XE 1	XE 1	XE 1	XE 1	P. 350
5-step transformer	TRE 0,4-2	TRE 0,4-2	TRE 0,4-2	TRE 0,4-2	TRE 0,4-2	TRE 0,4-2	P. 340
5-step transformer, control cabinet	TRE 1,6 S-2	TRE 1,6 S-2	TRE 1,6 S-2	TRE 1,6 S-2	TRE 1,6 S-2	TRE 1,6 S-2	P. 341
5-step switch for TRE...S -2/ TR...S-2 5-step transformer	ESS 20	ESS 20	ESS 20	ESS 20	ESS 20	ESS 20	P. 341

Accessories EN / ENR

**Wall sleeves
WH 20/25/31**



Article	Art. No.	Nominal size mm
WH 20	0059.0229	200
WH 25	0059.0230	250
WH 31	0059.0231	315

- Wall sleeve for wall and roof installations.

Dimensions [mm]

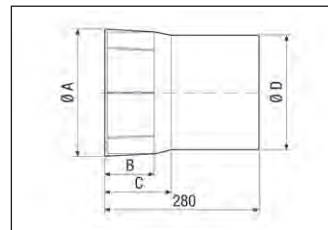

Common features

Material	Synthetic material
Installation site	Wall/Ceiling

Article	A mm	B mm	C mm	D mm
WH 20	237	90	120	212
WH 25	287	90	120	262
WH 31	356	126	155	328

**Extension sleeves
VH**



Article	Art. No.	Nominal size mm
VH 20	0055.0030	200
VH 25	0055.0031	250
VH 30	0055.0032	300
VH 31	0055.0037	315
VH 35	0055.0033	350
VH 40	0055.0034	400
VH 45	0055.0036	450
VH 50	0055.0035	500

- Extension sleeve for wall and roof installations.

Dimensions [mm]

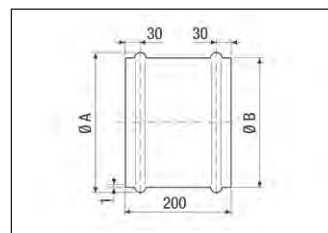

Common features

Material	Sheet steel, galvanised
Installation site	Wall/Ceiling

Article	A mm	B mm
VH 20	226	219
VH 25	276	269
VH 30	326	319
VH 31	342	335
VH 35	376	369
VH 40	426	419
VH 45	471	467
VH 50	526	522

**Dark room attachment
ZDK 25**



Article	Art. No.
ZDK 25	0093.0350

- Dark room attachment to screen the light at the ventilation opening.
- Must be fitted inside the room.

Dimensions [mm]

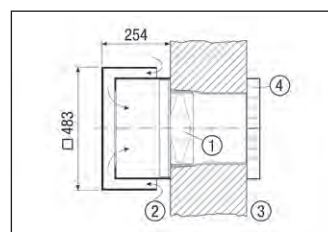

- ① EN/ENR fan
- ② Inside
- ③ Outside
- ④ External shutter

Features

Material	Sheet steel, powder coated
Colour	Black
Installation site	Wall/Ceiling
Air direction	Air extraction
Width	483 mm
Height	483 mm
Depth	254 mm



Models

- EVN 15, EVN 22: With air-stream-operated shutter, for air extraction.
- EVN 15 P, EVN 22 P: With air-stream-operated external shutter and with approx. 1 m long pull cord for manual operation for air extraction.
- EVN 22 R: With electrical external shutter – for ventilation and air extraction.

Features

- For installation in windows or thin walls.
- Quiet impeller.
 - EVN 15: Synthetic impeller.
 - EVN 22: Aluminium impeller.
- Maintenance-free fan.

Motor

- Thermal overload protection as standard feature. Switches motor off under thermal overload and comes on automatically again after cooling down.
- Robust motor with self-lubricating sintered bearings, maintenance-free.
- Suitable for continuous operation.

Electrical connection

- To terminal block in the housing.

Mounting instructions

- Pane thickness: 3 mm to 30 mm.
- Screws included in the scope of delivery.
- Also suited for thicker panes or walls. Appropriate mounting material must be provided by the customer.
- Not suited for installation in double-glazed windows that can be swung open.

Safety instructions

- Inside and outside protection against accidental contact in accordance with DIN EN ISO 13857.

Technical data

Article	Art. No.	Air direction	U_{nom}	f_{nom}	Rotating speed	Air flow volume	P_{nom}	I_{max}	T_{max} at I_{max}	Sound power level L_{WA7} dB(A)	Degree of protection IP	Mains cable mm ²	Weight kg
			V	Hz	1/min	m ³ /h	W	A	°C				
EVN 15	0080.0853	Air extraction	230	50	1,550	240	25	0.15	40	48	24	3 x 1.5	1.6
EVN 15 P	0080.0854	Air extraction	230	50	1,550	240	25	0.15	40	48	24	3 x 1.5	1.6
EVN 22	0080.0855	Air extraction	230	50	1,160	490	37	0.23	40	55	24	3 x 1.5	3.9
EVN 22 P	0080.0856	Air extraction	230	50	1,160	490	37	0.23	40	55	24	3 x 1.5	3.8
EVN 22 R	0080.0857	Ventilation or air extraction	230	50	1,280	640	49	0.23	40	57	24	4 x 1.5	4.2

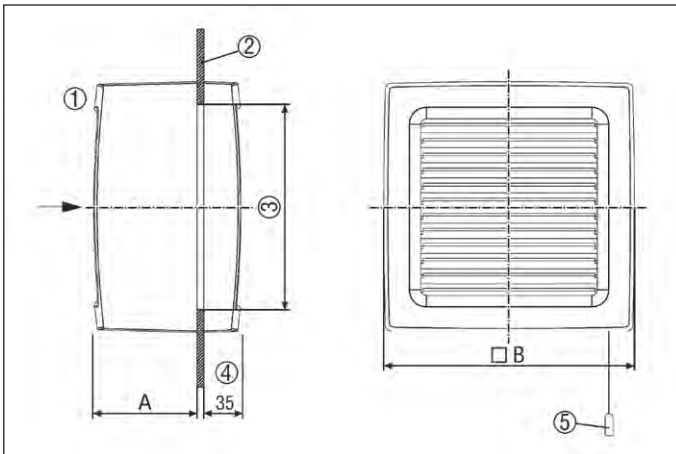
Dimensions [mm]

- ① Inside
- ② Window
- ③ EVN 15: Window cut-out: min. 184 mm, max. 195 mm diameter
EVN 22: Window cut-out: min. 257 mm, max. 262 mm diameter
- ④ EVN 15: 15 mm more with open lamella
EVN 22: 30 mm more with open lamella
- ⑤ Pull-cord only for EVN 15 P, EVN 22 P

Article	A	B
EVN 15	94	226
EVN 15 P	94	226
EVN 22	157	335
EVN 22 P	157	335
EVN 22 R	157	335

Accessories selection table

	EVN 15	EVN 15 P	EVN 22	EVN 22 P	EVN 22 R	see
General accessories						
Step switch, reversing switch	-	-	-	-	FS 6	P. 335
Reversing switch	-	-	-	-	FS 7	P. 335
Radio switch	XS 1	-	XS 1	-	XS 1	P. 350
Radio receiver	XE 1	-	XE 1	-	XE 1	P. 350
5-step transformer	-	-	-	-	TRE 0,4-2	P. 340



Models

- EV: With electrical internal shutter for air extraction.
- EVR: With electrical internal shutter for ventilation or air extraction.
- EVH: Internal shutter with pull-cord of approx. 1 m length for manual operation for air extraction.

Features

- For installation in windows or thin walls.
- Depth of outer part is only 23 mm. Therefore no conflict with shutters or blinds.
- Quiet synthetic impeller.
- Maintenance-free fan.
- IP 20 degree of protection, not suited for damp rooms.

Motor

- Thermal overload protection as standard feature. Switches motor off under thermal overload and comes on automatically again after cooling down.
- Robust motor with ball bearing, maintenance-free.
- Suitable for continuous operation.

Electrical connection

- To terminal block in the housing.

Mounting instructions

- Easy installation. Mounting with included screws.
- Also suited for thicker panes or walls. Appropriate mounting material must be provided by the customer.
- Pane thickness:
 - EV 31 = 4-20 mm
 - EVR 31 = 4-20 mm
 - EVH 31 = 6-20 mm

Safety instructions

- Inside and outside protection against accidental contact in accordance with DIN EN ISO 13857.

Technical data

Article	Art. No.	Air direction	U_{nom}	f_{nom}	Rotating speed	Air flow volume	P_{nom}	I_{max}	T_{max} at I_{max}	Sound power level L_{WA7} dB(A)	Degree of protection IP	Mains cable mm ²	Weight kg
			V	Hz	1/min	m ³ /h	W	A	°C				
EV 31	0080.0820	Air extraction	230	50	1,440	1,400	110	0.6	40	72	20	5 x 1.5	6.8
EVR 31	0080.0821	Ventilation or air extraction	230	50	1,410	1,400	110	0.6	40	72	20	5 x 1.5	6.8
EVH 31	0080.0822	Air extraction	230	50	1,425	1,400	110	0.6	40	72	20	3 x 1.5	6.7

Dimensions [mm]

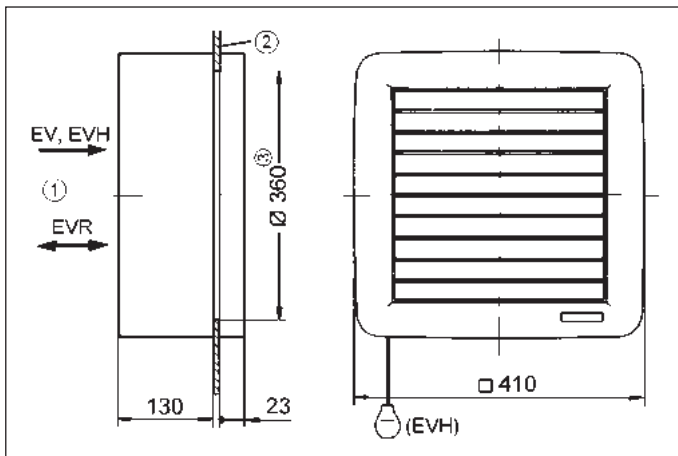

- ① Inside
- ② Window pane
- ③ Window cut-out: 360 mm diameter

Accessories selection table

	EV 31	EVR 31	EVH 31	see
General accessories				
Reversing switch	-	FS 7 UWK 1	-	P. 335 P. 338
Radio switch	XS 1	XS 1	-	P. 350
Radio receiver	XE 1	XE 1	-	P. 350
Speed controller	ST 1 STU 1	ST 1 STU 1	-	P. 338
Speed controller, distribution board	STS 2,5	STS 2,5	-	P. 339
Speed controller, reversing switch	-	STW 1	-	P. 339
5-step transformer	TRE 0,6-2	TRE 0,6-2	-	P. 340
5-step transformer, control cabinet	TRE 1,6 S-2	TRE 1,6 S-2	-	P. 341
5-step switch for TRE...S -2/ TR...S-2	ESS 20	ESS 20	-	P. 341
5-step transformer				



Features of ECO 30 E, ECO 40 D

- Oscillating fan.
- Suitable for wall installation.
- Minimum mounting height = 2.3 m (distance between lower impeller edge and floor).
- With yellow chromated protective cage, protection against accidental contact in accordance with DIN EN ISO 13857.
- 3-blade impeller made of plastic.
- Adjustable pivoting angle: 55°, 70°, 90° or 115°.
- Fan and swivel gear drives can be switched separately.

Features of EC 30 E, EC 40 D

- Ceiling fan with fastening rod for ceiling assembly.
- Suited for installation in rooms with a ceiling height lower than 2.3 m.
- With yellow chromated protective cage, protection against accidental contact in accordance with DIN EN ISO 13857.
- 3-blade impeller made of plastic.

Features of EC 90 B, EC 140 B

- For ceiling installation.
- Minimum mounting height = 2.3 m (distance between lower impeller edge and floor).
- Without protective cage.
- Enhanced heat utilisation in winter, comfortable cooling in summer thanks to air circulation. Resulting in temperature rises of up to 4 K near the floor in halls with high ceilings.
- Even distribution of temperature thanks to air circulation.
- The air flows from the ceiling to the floor.
- **EC 90 B:**
 - Version with medium air circulation.
 - With 3-blade synthetic impeller.
- **EC 140 B:**
 - Version with high air circulation.
 - With 3-blade aluminium impeller.

Mounting instructions

- Individual components must be fitted on site.
- Mounting hooks must be provided by the customer.

Motor

- Asynchronous motor.
- Thermal overload protection as standard feature.

Special versions

- The following special versions are available at extra cost on request:
 - Special voltages and frequencies.
- Information on operation at temperatures occasionally below -20 °C available upon request.
- If operating with frequency converters, the factory must be consulted.
- Feasibility must be checked in each case.

Installation advice for EC 90 B and EC 140 B ceiling fans

The diagram shows the recommended minimum spacing between several ceiling fans. Please bear in mind the following when fitting:

- In large rooms up to a height of 15 m, ceiling fans of type EC 140 B with a 1 m long fastening rod are recommended.
- Keep to the distances between the individual ceiling fans as indicated in the illustration.
- Do not mount ceiling fans directly above work areas.
- MAICO recommends controlling the ceiling fans as a group in rooms with different temperature areas, e.g. production halls and warehouses. To achieve this effect, groups of fans are controlled with an appropriate speed controller.

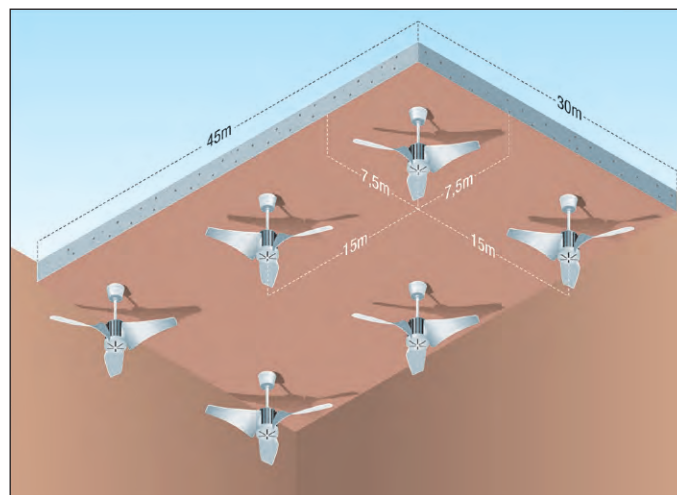

Technical data

Article	Art. No.	U _{nom} V	Rotating speed 1/min	Air circulation m ³ /h	I _{max} A	T _{max} at I _{max} °C	Impeller diameter mm	Swivellable	Sound power level L _{WA1} dB(A)	Degree of protection IP	Weight kg
ECO 30 E	0088.0010	230	1,350	2,800	0.25	40	300	✓	57	20	3.1
ECO 40 D	0088.0014	230	1,150	4,500	0.25	40	400	✓	65	20	4
EC 30 E	0088.0001	230	1,350	2,800	0.25	40	300	–	57	20	2.5
EC 40 D	0088.0005	230	1,150	4,500	0.2	40	400	–	65	20	3.2
EC 90 B	0088.0121	230	360	11,000	0.55	40	900	–	62	20	5.3
EC 140 B	0088.0176	230	245	18,000	0.6	40	1,400	–	63	20	8.4

Dimensions [mm] ECO

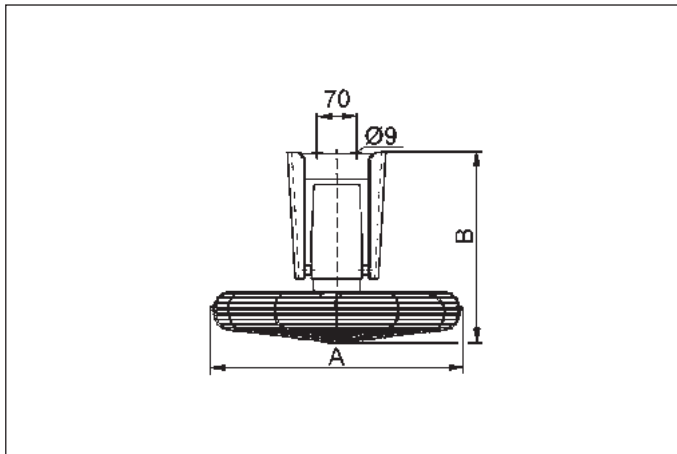

Article	A	B
ECO 30 E	345	330
ECO 40 D	450	340

Dimensions [mm] EC 90 B / EC 140 B

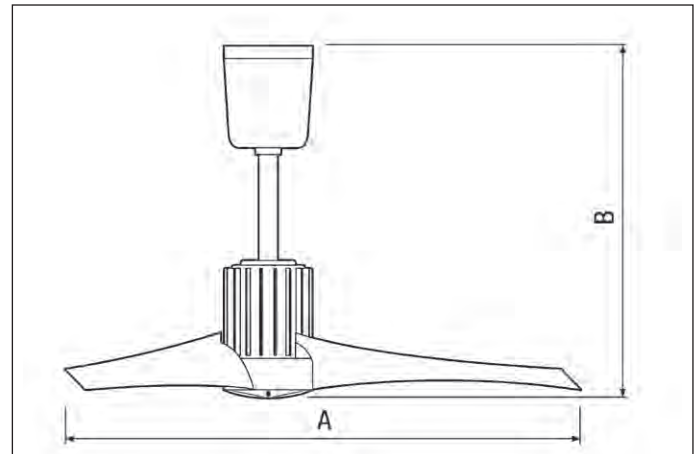

Dimension B with standard rod (250 mm)

Article	A	B
EC 90 B	900	450
EC 140 B	1,400	420

Dimensions [mm] EC 30 E / EC 40 D

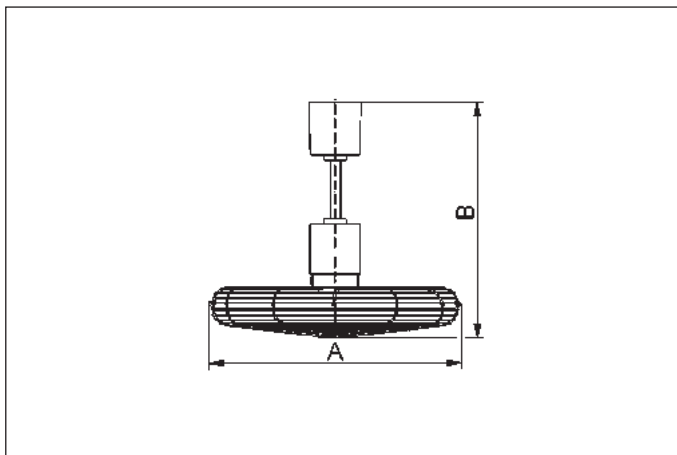

Dimension B with standard rod (250 mm)

Article	A	B
EC 30 E	345	410
EC 40 D	450	420

Accessories

Fastening rods

- Longer rods for ceiling fans, instead of standard rods (0.25 m long).

Article	Art. No.	Suitable for products
Rod 0,5 m	0093.0183	EC 90 B, EC 140 B
Rod 1,0 m	0093.0184	EC 90 B, EC 140 B
Rod 0,5 m	0093.0298	EC 30 E, EC 40 D
Rod 1,0 m	0093.0299	EC 30 E, EC 40 D

Accessories selection table

	ECO 30 E	ECO 40 D	EC 30 E	EC 40 D	EC 90 B	EC 140 B	see
Specific accessories							
Fastening rod	-	-	Rod 0,5 m Rod 1,0 m	Rod 0,5 m Rod 1,0 m	Rod 0,5 m Rod 1,0 m	Rod 0,5 m Rod 1,0 m	P. 185
General accessories							
Speed controller	ST 1 STU 1	ST 1 STU 1	ST 1 STU 1	ST 1 STU 1	ST 1 STU 1	ST 1 STU 1	P. 338
Speed controller, distribution board	STS 2,5	STS 2,5	STS 2,5	STS 2,5	STS 2,5	STS 2,5	P. 339
5-step transformer	TRE 0,4-2	TRE 0,4-2	TRE 0,4-2	TRE 0,4-2	TRE 0,6-2	TRE 0,6-2	P. 340
5-step transformer, control cabinet	TRE 1,6 S-2	TRE 1,6 S-2	TRE 1,6 S-2	TRE 1,6 S-2	TRE 1,6 S-2	TRE 1,6 S-2	P. 341
5-step switch for TRE...S -2/ TR...S-2 5-step transformer.	ESS 20	ESS 20	ESS 20	ESS 20	ESS 20	ESS 20	P. 341
Thermostat	-	-	THD 10	THD 10	THD 10	THD 10	P. 344

EZG axial greenhouse fan for air circulation**Air circulation**

- Moving air improves the growth of plants. It is extremely important for their health and a balanced culture area.
- It reduces air humidity in the culture area.
- This prevents fungal attacks and rotting as well as damage to the flowers and the flowers falling off.
- Air circulation widely reduces damage caused by botrytis or grey scale and enhances the stem quality of cut flowers.
- A uniform temperature distribution simultaneously reduces costs for personnel, heating and pesticides.

Features

- Duct sleeve made of galvanised sheet-steel, with synthetic resin varnish.
- Mounting lugs for suspension from the roof construction.
- With protective grilles on both sides, protection against accidental contact in accordance with DIN EN ISO 13857.
- 8-blade plastic impeller.

Air flow direction

- Airstream and rotational direction are marked by arrows on the duct sleeve.

Motor

- Asynchronous motor.
- Reversible.
- Thermal overload protection as standard feature.

Electrical connection

- Ready for connecting with a 2 m flexible connecting duct with plug.

Special versions

- The following special versions are available at extra cost on request:
 - Special voltages and frequencies.
 - Single-phase motors with thermal contacts or PTC thermistor, with potential-free terminal connections.
 - Fans with enhanced anti-corrosion protection.
- Information on operation at temperatures occasionally below -20°C available upon request.
- If operating with frequency converters, the factory must be consulted.
- Feasibility must be checked in each case.

Technical data

Article	Art. No.	U _{nom} V	f _{nom} Hz	Air flow volume m ³ /h	Rotating speed 1/min	P _{nom} W	I _{max} A	T _{max} at I _{max} °C	Sound power level L _{WA1} dB(A)	Degree of protection IP	Insulation class	Weight kg
EZG 30/4 B	0085.0150	230	50	1,600	1,425	90	0.5	60	73	55	B	9.1
EZG 35/4 B	0085.0151	230	50	2,400	1,425	120	0.7	60	78	55	B	9.8
EZG 40/4 B	0085.0152	230	50	3,800	1,425	230	1.25	60	83	55	F	11.5

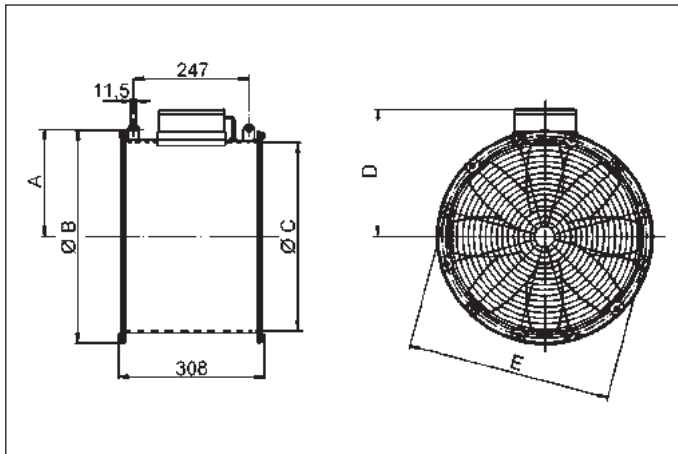
Dimensions [mm]

Article	A	B	C	D	E
EZG 30/4 B	182	380	313	222	356
EZG 35/4 B	207	420	363	248	395
EZG 40/4 B	232	460	413	274	438

Accessories selection table

	EZG 30/4 B	EZG 35/4 B	EZG 40/4 B	see
General accessories				
Main switch, service switch	HS 3	HS 3	HS 3	P. 334
Rotary switch	DS 10	DS 10	DS 10	P. 334
Speed controller	ST 1	ST 1	ST 2,5	P. 338
5-step transformer	TRE 0,6-2	TRE 1,6-2	TRE 1,6-2	P. 340
5-step transformer, control cabinet	TRE 1,6 S-2	TRE 1,6 S-2	TRE 1,6 S-2	P. 341
5-step switch for TRE...S -2/ TR...S-2	ESS 20	ESS 20	ESS 20	P. 341
5-step transformer				
Thermostat	THR 10 TH 10 TH 16	THR 10 TH 10 TH 16	THR 10 TH 10 TH 16	P. 343 P. 344 P. 344
Temperature control system	EAT 6 TG	EAT 6 TG	EAT 6 TG	P. 345
Hygostat	HY 230 HY 230 I	HY 230 HY 230 I	HY 230 HY 230 I	P. 348
Air quality controller	EAQ 10/1	EAQ 10/1	EAQ 10/1	P. 349

Axial high-performance wall-mounted fans



EZF / DZF wall-mounted fan with wall sleeve

Recessed-mounted installation, up to 6,045 m³/h



Page 190

EZQ, DZQ /EZS, DZS wall-mounted fan with wall plate / wall ring

Up to 14,970 m³/h



Page 194

EZQ / DZQ wall-mounted fan, explosion proof

Up to 9,450 m³/h



Page 200

DAS axial fan

With steel wall ring, up to 72,000 m³/h

Wall-installation with QW accessory possible



Page 204

Accessories

Extension sleeves, air filters



Page 206



Features

- For recessed mounting.
- Can be fitted in any position.
- Wall sleeve made of galvanised sheet-steel.
- 8-blade impellers made of glass-fibre filled polyamide. Dynamically balanced at two levels, in accordance with performance level 6.3, DIN ISO 1940, Part 1.
- Protective grille made of plastic on the intake side, pearl white, protection against accidental contact in accordance with DIN ISO EN 13857.

Air flow direction

- The following illustration shows the air flow direction.

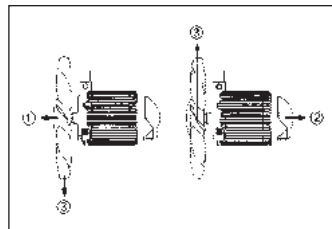

- ① Air flow direction A: With air drawn across the motor, standard
- ② Air flow direction B: With air blown across the motor, available on request
- ③ Rotational direction

- Reversing mode: The volumetric flow is reduced by approx. 35 % with abnormal air flow direction.

Motor

- Asynchronous motor.
- Reversible. Exception: Fans with shaded-pole motors (...-E).
- Not suitable for ventilating steam-saturated air.

AC motor

- EZF model series.
- Rated voltage 230 V, 50 Hz.
- Thermal overload protection as a standard feature.
- ".../B" fans: Capacitor motors with operating capacitor fitted to protective grille or to wall sleeve. IP 55 degree of protection.
- ".../D" fans: Capacitor motors with operating capacitor in terminal box. IP 54 degree of protection.
- ".../E" fans: Shaded-pole motors, non reversible. IP 54 degree of protection.

Three-phase AC motor

- DZF model series.
- Rated voltage 400 V, 50 Hz.
- IP 55 degree of protection. Exception DZF... D IP 54.
- Thermal overload protection as a standard feature. Exception: DZF .../D.
- Potential-free terminal connections, which must be connected to e.g. an MV 25 protective motor switch or the control circuit of a contactor.

Electrical connection

- To terminal block under the motor cover.

Safety instructions

- The fan can be operated only if the protection against accidental contact with the impeller is guaranteed to be in accordance with DIN EN ISO 13857 for fans with a free inlet.

Special versions

- The following special versions are available at extra cost on request:
 - Special voltages and frequencies.
 - Single-phase motors with thermal contacts or PTC thermistor, with potential-free terminal connections.
 - Impellers made of aluminium.
- Information on operation at temperatures occasionally below -20°C available upon request.
- If operating with frequency converters, the factory must be consulted.
- Feasibility must be checked in each case.

Technical data for units < 125 W

Article	Art. No.	U _{nom} V	f _{nom} Hz	Air flow volume m ³ /h	Rotating speed 1/min	P _{nom} W	I _{nom} A	I _{max} A	T _{max} at I _{max} °C	Sound power level L _{WA7} dB(A)	Weight kg
DN 200											
EZF 20/4 E	0085.0484	230	50	500	1,380	30	0.23	0.25	60	56	3.3
DN 250											
EZF 25/4 D	0085.0487	230	50	900	1,425	30	0.15	0.18	60	64	4.2
EZF 25/4 E	0085.0486	230	50	800	1,280	40	0.28	0.3	50	59	3.9
DZF 25/4 D	0085.0490	400	50	1,000	1,425	50	0.13	0.14	60	65	3.9
DN 300											
EZF 30/6 B	0085.0053	230	50	1,100	930	60	0.3	0.33	60	60	6.5
EZF 30/4 B	0085.0054	230	50	1,700	1,425	90	0.4	0.5	60	72	6.6
DZF 30/6 B	0085.0101	400	50	1,150	930	70	0.18	0.18	60	60	6.4
DZF 30/4 B	0085.0102	400	50	1,700	1,425	85	0.3	0.33	60	72	6.5
DN 350											
EZF 35/6 B	0085.0055	230	50	1,600	930	70	0.35	0.35	60	64	7.2
EZF 35/4 B	0085.0056	230	50	2,760	1,461	120	0.45	0.75	60	77	7.4
DZF 35/6 B	0085.0103	400	50	1,600	930	80	0.17	0.18	60	63	7.1
DN 400											
EZF 40/6 B	0085.0057	230	50	2,400	930	100	0.45	0.5	55	67	10.4
DZF 40/8 B	0085.0105	400	50	1,900	715	85	0.2	0.2	60	60	9.4
DZF 40/6 B	0085.0106	400	50	2,500	930	120	0.3	0.3	60	67	10.1
DN 500											
EZF 50/8 B	0085.0061	230	50	3,800	715	110	0.5	0.65	60	68	14.8

Technical data for units > 125 W according to ErP in Best Efficiency Point (BEP)

Article	Art. No.	U _{nom} V	f _{nom} Hz	Air flow volume m ³ /h	Sound power level _{WA7} dB(A)	Air volume _{nom} m ³ /h	Pressure p _{fs, nom} Pa	Rotating speed n _{nom} 1/min	P _{nom} W	I _{nom} A	I _{max} A	T _{max} at I _{max} °C	Weight kg	Efficiency level N	Total efficiency η %
DN 350															
DZF 35/4 B	0085.0104	400	50	2,710	78	1,645 ¹⁾	66 ¹⁾	1,465 ¹⁾	135 ¹⁾	0.55 ¹⁾	0.6	60	10.6	40.7	28.8
DN 400															
EZF 40/4 B	0085.0058	230	50	4,170	80	2,820 ¹⁾	78 ¹⁾	1,410 ¹⁾	230 ¹⁾	0.95 ¹⁾	1.6	60	10.6	41.1	30.7
DZF 40/4 B	0085.0107	400	50	4,200	81	2,640 ¹⁾	87 ¹⁾	1,440 ¹⁾	230 ¹⁾	0.6 ¹⁾	0.75	60	13	42.7	32.4
DN 450															
DZF 45/6 B	0085.0108	400	50	4,220	76	2,910 ¹⁾	53 ¹⁾	985 ¹⁾	170 ¹⁾	0.55 ¹⁾	0.6	60	19.4	40.5	29.2
DZF 45/4 B	0085.0109	400	50	6,045	85	3,970 ¹⁾	116 ¹⁾	1,380 ¹⁾	455 ¹⁾	0.8 ¹⁾	1.1	60	14.4	40.6	32.1
DN 500															
DZF 50/6 B	0085.0111	400	50	5,480	78	3,300 ¹⁾	67 ¹⁾	975 ¹⁾	220 ¹⁾	0.6 ¹⁾	0.7	60	20.4	42.9	32.5

¹⁾ In opt. efficiency

BEP measured in measurement category A, static efficiency category. For further ErP data, see www.maico-fans.com.
 Calculation of energy efficiency without protective grille.

Dimensions [mm]

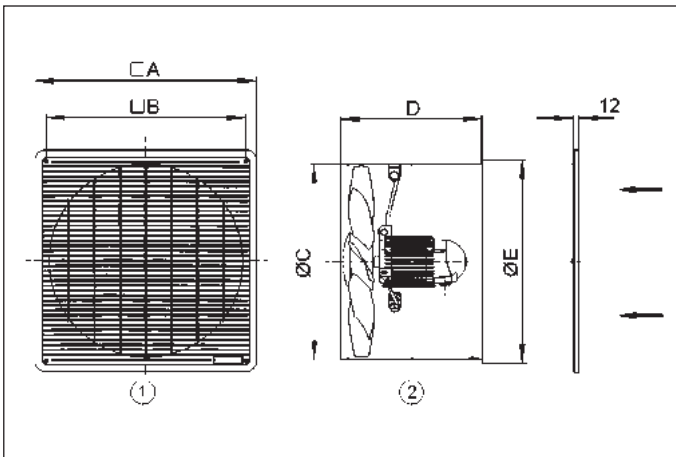

- ① Protective grille on intake side
- ② Air flow direction with air drawn across the motor

Nominal size	A	B	C	D	E
DN 200	258	212	216	240	-
DN 250	320	274	266	240	280
DN 300	365	319	316	300	330
DN 350	428	382	366	300	380
DN 400	470	424	416	300	430
DN 450	580	534	460	315	475
DN 500	580	534	517	315	530

Characteristic curves for DN 200 and DN 250

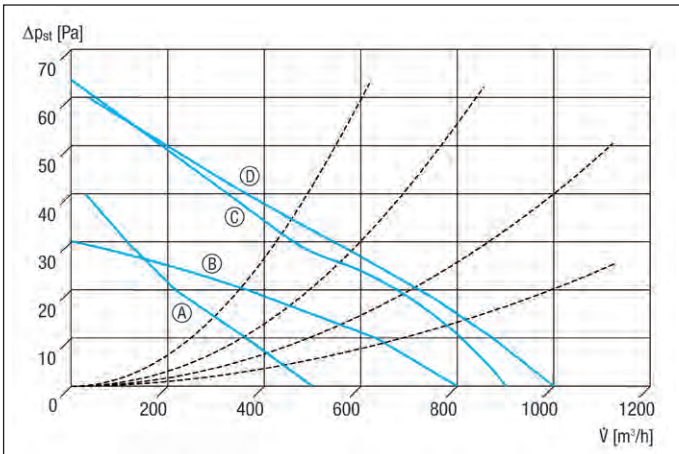

- Ⓐ EZF 20/4 E
- Ⓑ EZF 25/4 E
- Ⓒ EZF 25/4 D
- Ⓓ DZF 25/4 D

Characteristic curves for DN 300

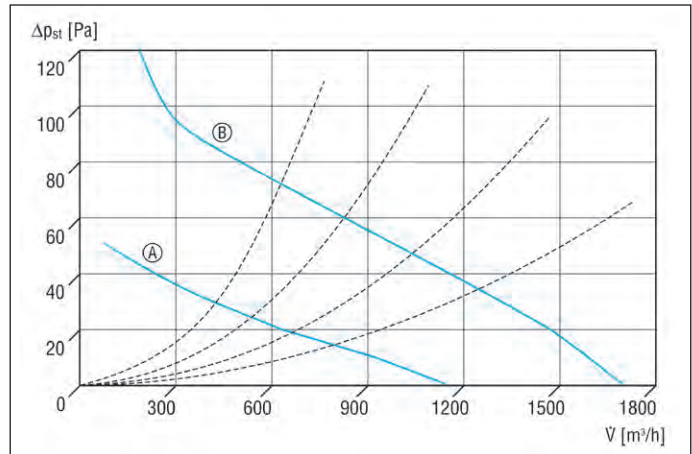

- Ⓐ EZF, DZF 30/6 B
- Ⓑ EZF, DZF 30/4 B

Characteristic curves for DN 350

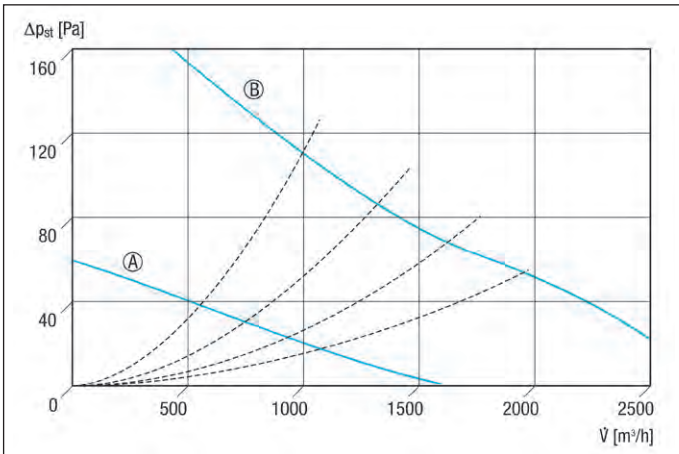

- Ⓐ EZF, DZF 35/6 B
- Ⓑ EZF, DZF 35/4 B

Characteristic curves for DN 400

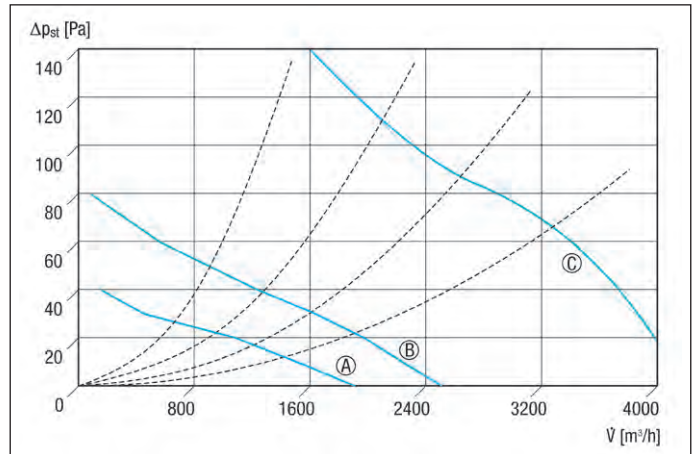

- Ⓐ DZF 40/8 B
- Ⓑ EZF, DZF 40/6 B
- Ⓒ EZF, DZF 40/4 B

Characteristic curves for DN 450

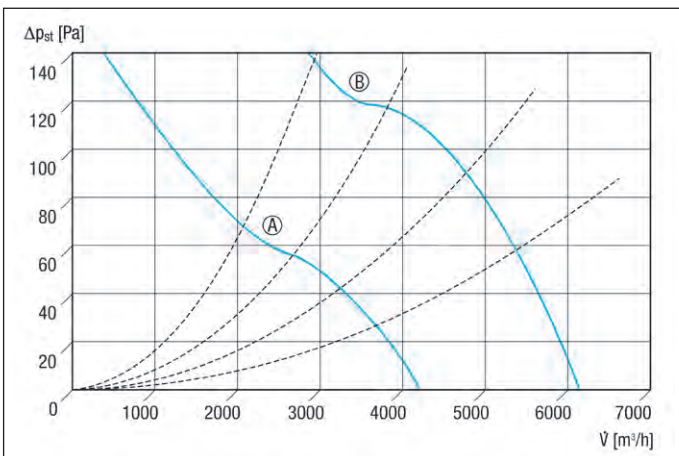

- Ⓐ DZF 45/6 B
- Ⓑ DZF 45/4 B

Characteristic curves for DN 500

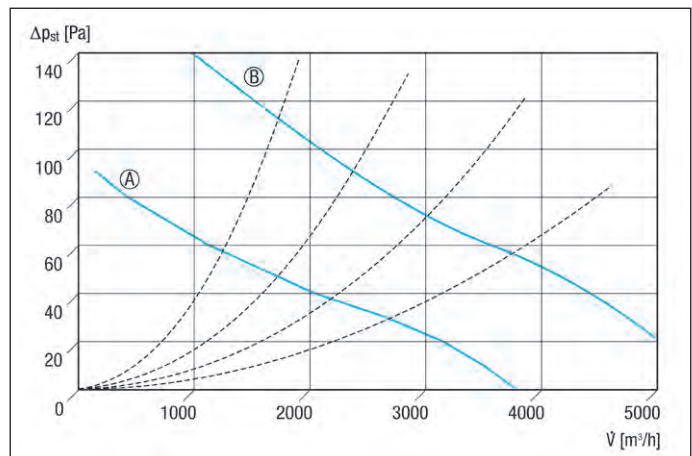

- Ⓐ EZF 50/8 B
- Ⓑ DZF 50/6 B

Accessories selection table

	EZF 20/4 E	EZF 25/4 D	EZF 25/4 E	DZF 25/4 D	EZF 30/6 B	EZF 30/4 B	DZF 30/6 B	see
General accessories								
Shutter	AS 20	AS 25	AS 25	AS 25	AS 30	AS 30	AS 30	P. 297
Shutter, manual	RS 20	RS 25	RS 25	RS 25	RS 30	RS 30	RS 30	P. 299
External grille	MLA 20 MLZ 20	MLA 25 MLZ 25	MLA 25 MLZ 25	MLA 25 MLZ 25	MLA 30 MLZ 30	MLA 30 MLZ 30	MLA 30 MLZ 30	P. 305
Extension sleeve	VH 20	VH 25	VH 25	VH 25	VH 30	VH 30	VH 30	P. 206
Air filter	ZFF 20	ZFF 30	ZFF 30	ZFF 30	ZFF 30	ZFF 30	ZFF 30	P. 207
Reversing switch	–	W 1 WU 1	–	–	W 1 WU 1	W 1 WU 1	W 1 WU 1	P. 334
Speed controller	ST 1 STU 1	ST 1 STU 1	ST 1 STU 1	–	ST 1 STU 1	ST 1 STU 1	–	P. 338
Speed controller, reversing switch	–	STW 1	–	–	STW 1	STW 1	–	P. 339
5-step transformer	TRE 0,4-2	TRE 0,4-2	TRE 0,4-2	TR 0,4-2	TRE 0,4-2	TRE 0,6-2	TR 0,4-2	P. 340
5-step transformer, control cabinet	TRE 1,6 S-2	TRE 1,6 S-2	TRE 1,6 S-2	TR 0,8 S-2	TRE 1,6 S-2	TRE 1,6 S-2	TR 0,8 S-2	P. 341
5-step switch for TRE...S -2/ TR...S-2 5-step transformer	ESS 20	ESS 20	ESS 20	DSS 20	ESS 20	ESS 20	DSS 20	P. 341
Temperature control system	EAT 6 G/1 EAT 6 TG	EAT 6 G/1 EAT 6 TG	EAT 6 G/1 EAT 6 TG	–	EAT 6 G/1 EAT 6 TG	EAT 6 G/1 EAT 6 TG	–	P. 345

	DZF 30/4 B	EZF 35/6 B	EZF 35/4 B	DZF 35/6 B	DZF 35/4 B	EZF 40/6 B	EZF 40/4 B	see
General accessories								
Shutter	AS 30	AS 35	AS 35	AS 35	AS 35	AS 40	AS 40	P. 297
Shutter, manual	RS 30	RS 35	RS 35	RS 35	RS 35	RS 40	RS 40	P. 299
External grille	MLA 30 MLZ 30	MLA 35 MLZ 35	MLA 35 MLZ 35	MLA 35 MLZ 35	MLA 35 MLZ 35	MLA 40 MLZ 40	MLA 40 MLZ 40	P. 305
Extension sleeve	VH 30	VH 35	VH 35	VH 35	VH 35	VH 40	VH 40	P. 206
Air filter	ZFF 30	ZFF 40	ZFF 40	ZFF 40	ZFF 40	–	–	P. 207
Reversing switch	W 1 WU 1	W 1 WU 1	W 1 WU 1	W 1 WU 1	W 1 WU 1	W 1 WU 1	W 1 WU 1	P. 334
Speed controller	–	ST 1 STU 1	ST 1 STU 1	–	–	ST 1 STU 1	ST 2,5 STU 2,5	P. 338
Speed controller, reversing switch	–	STW 1	STW 1	–	–	STW 1	STW 2,5	P. 339
5-step transformer	TR 0,4-2	TRE 0,4-2	TRE 1,6-2	TR 0,4-2	TR 0,8-2	TRE 0,6-2	TRE 1,6-2	P. 340
5-step transformer, control cabinet	TR 0,8 S-2	TRE 1,6 S-2	TRE 1,6 S-2	TR 0,8 S-2	TR 0,8 S-2	TRE 1,6 S-2	TRE 1,6 S-2	P. 341
5-step switch for TRE...S -2/ TR...S-2 5-step transformer	DSS 20	ESS 20	ESS 20	DSS 20	DSS 20	ESS 20	ESS 20	P. 341
Temperature control system	–	EAT 6 G/1 EAT 6 TG	EAT 6 G/1 EAT 6 TG	–	–	EAT 6 G/1 EAT 6 TG	EAT 6 G/1 EAT 6 TG	P. 345

	DZF 40/8 B	DZF 40/6 B	DZF 40/4 B	DZF 45/6 B	DZF 45/4 B	EZF 50/8 B	DZF 50/6 B	see
General accessories								
Shutter	AS 40	AS 40	AS 40	AS 45	AS 45	AS 50	AS 50	P. 297
Shutter, manual	RS 40	RS 40	RS 40	RS 45	RS 45	RS 50	RS 50	P. 299
External grille	MLA 40 MLZ 40	MLA 40 MLZ 40	MLA 40 MLZ 40	–	–	MLA 50 MLZ 50	MLA 50 MLZ 50	P. 305
Extension sleeve	VH 40	VH 40	VH 40	VH 45	VH 45	VH 50	VH 50	P. 206
Reversing switch	W 1 WU 1	W 1 WU 1	W 1 WU 1	W 1 WU 1	W 1 WU 1	W 1 WU 1	W 1 WU 1	P. 334
Speed controller	–	–	–	–	–	ST 1 STU 1	–	P. 338
Speed controller, reversing switch	–	–	–	–	–	STW 1	–	P. 339
5-step transformer	TR 0,4-2	TR 0,4-2	TR 0,8-2	TR 0,8-2	TR 2,5-2	TRE 1,6-2	TR 0,8-2	P. 340
5-step transformer, control cabinet	TR 0,8 S-2	TR 0,8 S-2	TR 0,8 S-2	TR 0,8 S-2	TR 2,5 S-2	TRE 1,6 S-2	TR 0,8 S-2	P. 341
5-step switch for TRE...S -2/ TR...S-2 5-step transformer	DSS 20	DSS 20	DSS 20	DSS 20	DSS 20	ESS 20	DSS 20	P. 341
Temperature control system	–	–	–	–	–	EAT 6 G/1 EAT 6 TG	–	P. 345



Models

- EZQ/DZQ series models with square wall plates.
- EZS/DZS series models with steel wall rings.
- Single- and three-phase AC versions.
- Pole-changeable version, for two speeds.

Features

- Yellow chromated protective grille on the intake side, protection against accidental contact in accordance with DIN EN ISO 13857.
- 8-blade impellers made of glass-fibre filled polyamide. Dynamically balanced at two levels, in accordance with performance level 6.3, DIN ISO 1940, Part 1.
- Can be fitted in any position.

Air flow direction

- The following illustration shows the air flow direction:

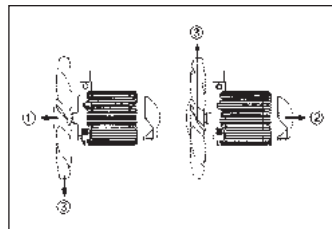

- ① Air flow direction A: With air drawn across the motor, standard
- ② Air flow direction B: With air blown across the motor, available on request
- ③ Rotational direction
- Reversing mode: The volumetric flow is reduced by approx. 35 % with abnormal air flow direction.

Motor

- Asynchronous motor.
- Speed controllable. Exception: Type EZQ 45/6 B, EZS 45/6 B, DZQ 40/2 B and DZS 40/2 B.
- Reversible. Exception: Fans with shaded-pole motors (...-E).
- Not suitable for ventilating steam-saturated air.

AC motor

- EZQ and EZS model series.
- Rated voltage 230 V, 50 Hz.
- Thermal overload protection as a standard feature.
- ".../B" fans: Capacitor motors with operating capacitor fitted to protective grille or to wall sleeve, IP 55 degree of protection.
- ".../D" fans: Capacitor motors with operating capacitor in terminal box, IP 54 degree of protection.
- ".../E" fans: Shaded-pole motors, non reversible, IP 54 degree of protection.

Three-phase AC motor

- DZQ and DZS model series.
- Rated voltage 400 V, 50 Hz.
- IP 55 degree of protection. Exception DZQ/DZS... D IP 54.
- Thermal overload protection as a standard feature. Exception: available on request for DZQ/DZS 25/4 D and pole-changeable axial duct fans.
- Potential-free terminal connections, which must be connected to e.g. an MV 25 protective motor switch or the control circuit of a contactor.

- Pole-changeable fans: Ensure overload protection is guaranteed by a motor protection switch provided by the customer.
- Pole-changeable motors with speed ratios of 8/4 or 4/2 have a Dahlander pole-changing circuit.

Electrical connection

- To terminal block under the motor cover.

Safety instructions

- The fan may be operated only if the protection against accidental contact with the impeller is guaranteed to be in accordance with DIN EN ISO 13857.

Special versions

- The following special versions are available at extra cost on request:
 - Special voltages and frequencies.
 - Single-phase motors with thermal contacts or PTC thermistor, with potential-free terminal connections.
 - Condensation drainage holes.
 - Fans with enhanced anti-corrosion protection.
 - Impellers made of aluminium.
- Information on operation at temperatures occasionally below -20°C available upon request.
- If operating with frequency converters, the factory must be consulted.
- Feasibility must be checked in each case.

Technical data for units < 125 W

Article	Art. No.	U _{nom} V	f _{nom} Hz	Air flow volume m ³ /h	Rotating speed 1/min	P _{nom} W	I _{nom} A	I _{max} A	T _{max} at I _{max} °C	Sound power level L _{WAT} dB(A)	Weight kg	Pole-changeable
DN 200												
EZQ 20/4 E	0083.0484	230	50	475	1,380	35	0.25	0.25	60	57	3.6	–
EZQ 20/2 B	0083.0102	230	50	1,100	2,850	65	0.3	0.47	60	74	5.5	–
DZQ 20/2 B	0083.0116	400	50	1,150	2,850	65	0.17	0.24	60	74	5.5	–
DN 250												
EZQ 25/4 E	0083.0486	230	50	800	1,280	40	0.25	0.28	50	61	4.2	–
EZQ 25/4 D	0083.0487	230	50	1,000	1,425	32	0.16	0.2	60	64	4.6	–
DZQ 25/4 D	0083.0490	400	50	1,000	1,425	45	0.13	0.13	40	65	4.3	–
DZQ 25/84 B	0083.0141	400	50	500/1,100	715/1,425	35/80	0.1/0.3	0.1/0.3	60	45/63	6	✓
DN 300												
EZQ 30/6 B	0083.0105	230	50	1,200	930	60	0.32	0.35	60	57	7.8	–
EZQ 30/4 B	0083.0106	230	50	1,850	1,425	90	0.4	0.55	60	68	7.9	–
DZQ 30/6 B	0083.0119	400	50	1,250	930	70	0.17	0.17	60	56	7.7	–
DZQ 30/4 B	0083.0120	400	50	1,850	1,425	85	0.31	0.35	60	66	7.8	–
DZQ 30/84 B	0083.0145	400	50	900/1,800	715/1,425	40/100	0.1/0.3	0.1/0.3	60	49/76	7.7	✓
DN 350												
EZQ 35/6 B	0083.0108	230	50	1,700	930	70	0.35	0.35	60	59	9.1	–
DZQ 35/6 B	0083.0122	400	50	1,700	930	75	0.17	0.17	60	58	9	–
DN 400												
EZQ 40/6 B	0083.0110	230	50	2,600	935	100	0.5	0.5	60	63	11.1	–
DZQ 40/8 B	0083.0125	400	50	2,050	715	75	0.2	0.2	60	57	11.2	–
DZQ 40/6 B	0083.0126	400	50	2,500	930	110	0.3	0.3	60	63	11	–
DN 500												
EZQ 50/8 B	0083.0112	230	50	4,200	715	110	0.55	0.6	60	65	17.6	–

Technical data for units > 125 W according to ErP in Best Efficiency Point (BEP)

Article	Art. No.	U _{nom} V	Air flow volume m ³ /h	Sound power level _{WA7} dB(A)	Air volume _{nom} m ³ /h	Pressure P _{fs, nom} Pa	Rotating speed n _{nom} 1/min	P _{nom} W	I _{nom} A	I _{max} A	T _{max} at I _{max} °C	Weight kg	Pole-changeable	Efficiency level N	Total efficiency η %
DN 250															
EZQ 25/2 B	0083.0104	230	2,100	80	1,470 ¹⁾	135 ¹⁾	2,770 ¹⁾	185 ¹⁾	0.75 ¹⁾	1.1	60	4.3	–	40.8	29.8
DZQ 25/2 B	0083.0118	400	2,120	81	1,510 ¹⁾	140 ¹⁾	2,870 ¹⁾	175 ¹⁾	0.35 ¹⁾	0.45	60	7	–	44.7	33.6
DZQ 25/42 B	0083.0142	400	1,050/2,190	63/80	745/1,550 ¹⁾	35/140 ¹⁾	1,430/2,810 ¹⁾	38/203 ¹⁾	0.1/0.35 ¹⁾	0.5	60	6	✓	40.4	29.7
DN 300															
EZQ 30/2 B	0083.0107	230	3,620	88	2,700 ¹⁾	170 ¹⁾	2,840 ¹⁾	350 ¹⁾	1.6 ¹⁾	2.7	40	11.7	–	45.6	36.4
DZQ 30/2 B	0083.0121	400	3,640	88	2,520 ¹⁾	190 ¹⁾	2,810 ¹⁾	375 ¹⁾	0.85 ¹⁾	1.1	60	11.6	–	44.6	35.6
DZQ 30/42 B	0083.0147	400	1,870/3,680	69/88	1,260/2,700 ¹⁾	53/185 ¹⁾	1,460/2,850 ¹⁾	70/415 ¹⁾	0.3/1 ¹⁾	1.3	60	11.3	✓	42.2	33.4
DN 350															
EZQ 35/4 B	0083.0114	230	2,810	70	1,870 ¹⁾	70 ¹⁾	1,390 ¹⁾	128 ¹⁾	0.55 ¹⁾	0.8	60	9.2	–	40.4	28.4
DZQ 35/4 B	0083.0123	400	2,840	69	1,950 ¹⁾	70 ¹⁾	1,380 ¹⁾	133 ¹⁾	0.35 ¹⁾	0.4	60	9.1	–	40.4	28.5
DZQ 35/2 B	0083.0060	400	5,750	90	4,040 ¹⁾	260 ¹⁾	2,830 ¹⁾	760 ¹⁾	1.3 ¹⁾	1.9	60	13	–	45.5	38.4
DZQ 35/84 B	0083.0150	400	1,430/2,960	56/73	945/2,070 ¹⁾	20/75 ¹⁾	730/1,460 ¹⁾	38/150 ¹⁾	0.2/0.5 ¹⁾	0.55	60	12.6	✓	40.3	28.8
DZQ 35/42 B	0083.0066	400	2,950/5,840	73/90	1,990/4,250 ¹⁾	75/255 ¹⁾	1,460/2,830 ¹⁾	135/810 ¹⁾	0.4/1.4 ¹⁾	2	60	12.7	✓	44.1	37.2
DN 400															
EZQ 40/4 B	0083.0115	230	4,350	81	3,060 ¹⁾	88 ¹⁾	1,380 ¹⁾	249 ¹⁾	1.1 ¹⁾	1.5	60	11.2	–	40.2	30
DZQ 40/4 B	0083.0127	400	4,260	73	3,080 ¹⁾	85 ¹⁾	1,375 ¹⁾	240 ¹⁾	0.6 ¹⁾	0.7	60	11.1	–	40.5	30.3
DZQ 40/2 B	0083.0061	400	8,920	94	6,680 ¹⁾	360 ¹⁾	2,920 ¹⁾	1,550 ¹⁾	2.6 ¹⁾	4.1	60	22.9	–	48.1	43
DZQ 40/84 B	0083.0155	400	2,170/4,420	59/75	1,490/3,040 ¹⁾	23/96 ¹⁾	720/1,430 ¹⁾	45/250 ¹⁾	0.2/0.55 ¹⁾	0.8	60	13.9	✓	42.7	32.6
DZQ 40/42 B	0083.0067	400	4,490/8,960	78/94	3,270/6,700 ¹⁾	95/350 ¹⁾	1,480/2,920 ¹⁾	245/1,585 ¹⁾	0.75/2.6 ¹⁾	4.3	60	22.4	✓	46.2	41.1
DN 450															
EZQ 45/6 B	0083.0100	230	4,490	72	2,945 ¹⁾	66 ¹⁾	955 ¹⁾	185 ¹⁾	1 ¹⁾	1.3	60	15.6	–	40.1	29.2
DZQ 45/4 B	0083.0101	230	6,650	82	4,620 ¹⁾	109 ¹⁾	1,315 ¹⁾	444 ¹⁾	1.9 ¹⁾	2.4	45	19.5	–	40.1	31.5
DZQ 45/6 B	0083.0137	400	4,460	72	3,160 ¹⁾	60 ¹⁾	990 ¹⁾	165 ¹⁾	0.55 ¹⁾	0.6	60	20.5	–	43.2	31.9
DZQ 45/4 B	0083.0138	400	6,580	81	4,480 ¹⁾	125 ¹⁾	1,390 ¹⁾	440 ¹⁾	0.8 ¹⁾	1.1	60	15.7	–	43.9	35.4
DN 500															
EZQ 50/6 B	0083.0113	230	5,860	72	4,240 ¹⁾	62 ¹⁾	955 ¹⁾	240 ¹⁾	1.1 ¹⁾	1.6	50	17.7	–	40.7	30.4
DZQ 50/6 B	0083.0130	400	5,880	73	4,350 ¹⁾	60 ¹⁾	950 ¹⁾	240 ¹⁾	0.7 ¹⁾	0.8	60	17.5	–	40.4	30.2
DZQ 50/4 B	0083.0062	400	8,700	82	6,310 ¹⁾	135 ¹⁾	1,410 ¹⁾	615 ¹⁾	1.1 ¹⁾	1.6	60	18.6	–	46.1	38.5
DZQ 50/84 B	0083.0160	400	4,370/8,890	65/82	3,040/6,600 ¹⁾	38/145 ¹⁾	730/1,460 ¹⁾	140/695 ¹⁾	0.5/1.4 ¹⁾	2	60	23.6	✓	45.6	38.2
DN 560															
DZQ 56/6 B	0083.0063	400	8,530	74	5,720 ¹⁾	91 ¹⁾	950 ¹⁾	455 ¹⁾	1.05 ¹⁾	1.2	60	20.5	–	40.3	31.8
DZQ 56/4 B	0083.0136	400	12,340	84	8,430 ¹⁾	187 ¹⁾	1,390 ¹⁾	1,170 ¹⁾	1.9 ¹⁾	2.8	60	33.8	–	43.3	37.4
DN 600															
DZQ 60/8 B	0083.0064	400	7,420	69	5,250 ¹⁾	50 ¹⁾	685 ¹⁾	243 ¹⁾	0.65 ¹⁾	0.85	60	22	–	40.2	30
DZQ 60/6 B	0083.0065	400	9,830	78	7,030 ¹⁾	90 ¹⁾	935 ¹⁾	525 ¹⁾	1.1 ¹⁾	1.4	60	20	–	41.6	33.5
DZQ 60/4 B	0083.0134	400	14,560	86	10,800 ¹⁾	175 ¹⁾	1,370 ¹⁾	1,385 ¹⁾	2.2 ¹⁾	3.5	60	33.3	–	43.3	37.9
DZQ 60/84 B	0083.0164	400	7,490/14,970	71/87	5,480/10,790 ¹⁾	52/210 ¹⁾	720/1,425 ¹⁾	250/1,600 ¹⁾	1/3 ¹⁾	4.3	60	32.9	✓	44.4	39.3

¹⁾ In opt. efficiency

BEP measured in measurement category A, static efficiency category. For further ErP data, see www.maico-fans.com. EZS/DZS models fans are also available with a round steel wall ring instead of EZQ/DZQ models with square wall plates (Exception: Nominal sizes DN 450 and DN 560). Technical data, prices and accessories are the same as for EZQ/DZQ model series. Delivery times on request.

Dimensions [mm]

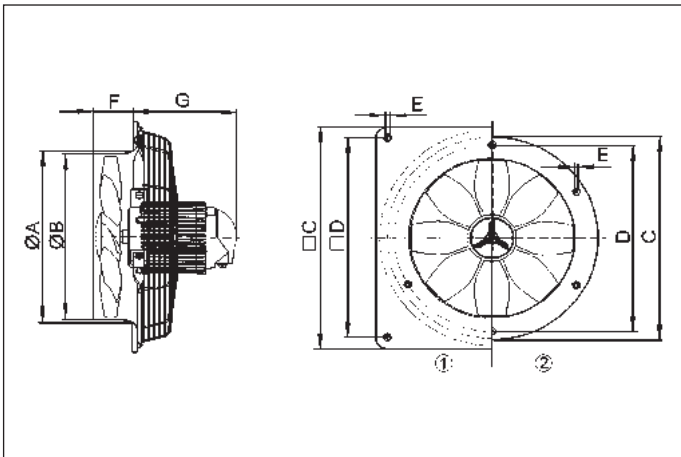

- ① Steel wall plate = EZQ/DZQ model
- ② Steel wall ring = EZS/DZS model

Nominal size	A	B	C	D	E	F	G max
DN 200 EZQ/DZQ	216.7	215	345	305	8.5	44.5	193
DN 200 EZS/DZS	218.9	215	297	250	10.4	60	193
DN 250 EZQ/DZQ	271.1	265	400	350	8.5	57.5	201
DN 250 EZS/DZS	271.6	263	353	306	10.4	80	201
DN 300 EZQ/DZQ	326.9	315	465	405	11	77.5	192
DN 300 EZS/DZS	330.4	313	420	370	10.4	87	192
DN 350 EZQ/DZQ	380.5	365	525	465	11	90.5	192
DN 350 EZS/DZS	386.6	364	476	428	10.4	95	192
DN 400 EZQ/DZQ	430.8	417	580	520	11	100	236
DN 400 EZS/DZS	442.6	414	533	485	10.4	109	236
DN 450 EZQ/DZQ	474	461	630	570	11	107	192
DN 500 EZQ/DZQ	542.7	516	700	640	11	137	203
DN 500 EZS/DZS	556.1	514	650	602	10.4	138	203
DN 560 DZQ	600.5	573	765	695	11	122	261
DN 600 DZQ	652.2	615	820	740	11	140	261
DN 600 DZS	666.9	614	772	724	10.4	138	261

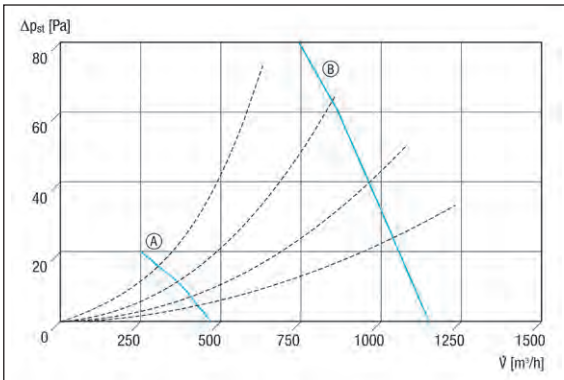
Characteristic curves for DN 200

Ⓐ EZQ 20/4 E Ⓑ EZQ, DZQ 20/2 B

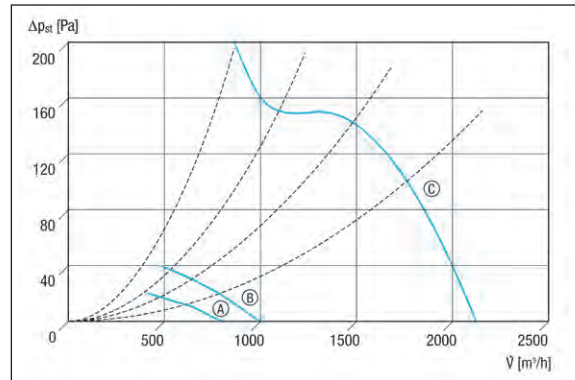
Characteristic curves for DN 250

Ⓐ EZQ 25/4 E Ⓑ EZQ, DZQ 25/4 D Ⓒ EZQ, DZQ 25/2 B

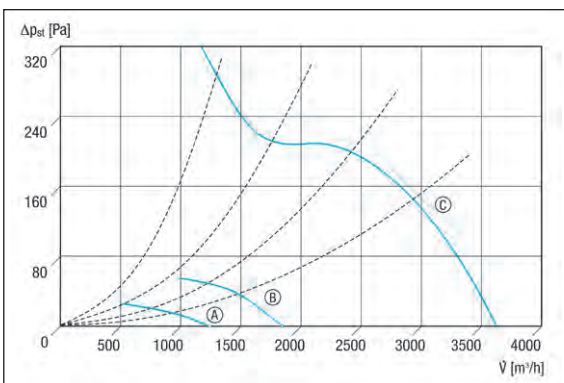
Characteristic curves for DN 300

Ⓐ EZQ, DZQ 30/6 B Ⓑ EZQ, DZQ 30/4 B Ⓒ EZQ, DZQ 30/2 B

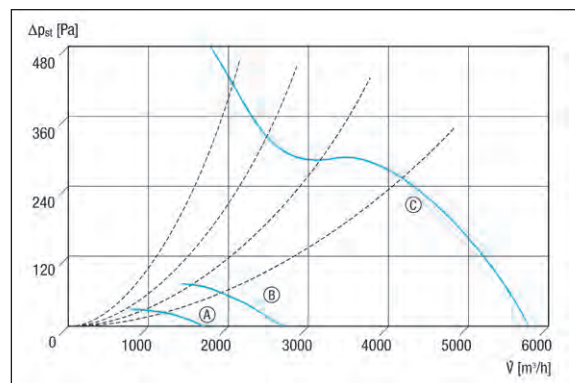
Characteristic curves for DN 350

Ⓐ EZQ, DZQ 35/6 B Ⓑ EZQ, DZQ 35/4 B Ⓒ DZQ 35/2 B

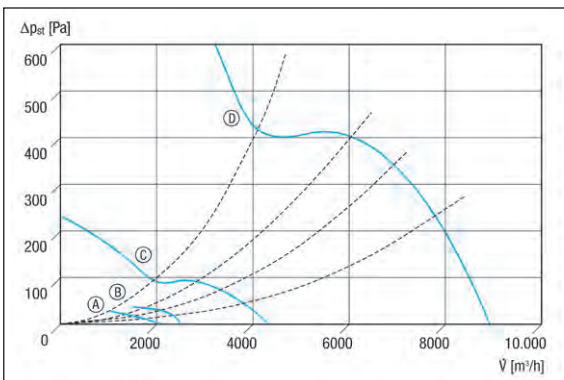
Characteristic curves for DN 400

Ⓐ DZQ 40/8 B Ⓑ EZQ, DZQ 40/6 B Ⓒ EZQ, DZQ 40/4 B Ⓓ DZQ 40/2 B

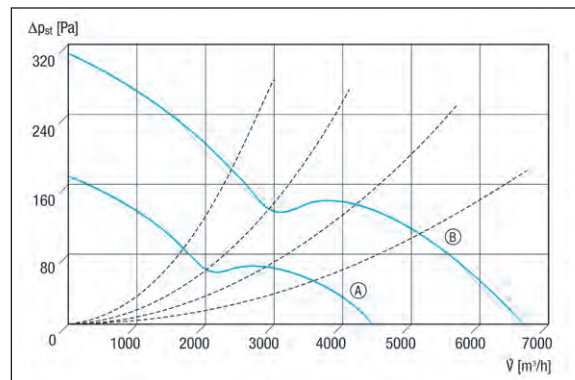
Characteristic curves for DN 450

Ⓐ EZQ, DZQ 45/6 B Ⓑ EZQ, DZQ 45/4 B

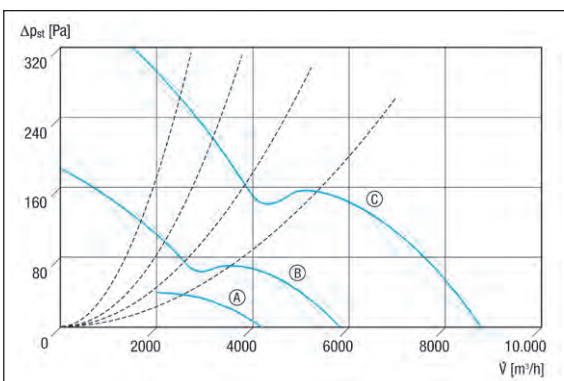
Characteristic curves for DN 500

Ⓐ EZQ 50/8 B Ⓑ EZQ, DZQ 50/6 B Ⓒ DZQ 50/4 B

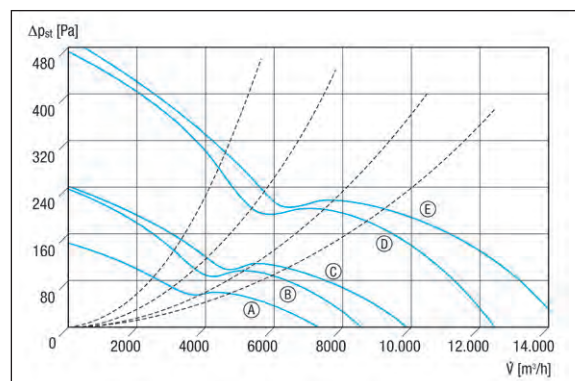
Characteristic curves for DN 560 and DN 600

Ⓐ DZQ 60/8 B Ⓑ DZQ 56/6 B Ⓒ DZQ 60/6 B Ⓓ DZQ 56/4 B Ⓔ DZQ 60/4 B

Accessories selection table

	EZQ 20/4 E	EZQ 20/2 B	DZQ 20/2 B	EZQ 25/4 E	EZQ 25/4 D	EZQ 25/2 B	DZQ 25/4 D	DZQ 25/2 B	see
General accessories									
Shutter	AS 20	AS 20	AS 20	AS 25	AS 25	AS 25	AS 25	AS 25	P. 297
Connection frame	ZVR 20	ZVR 20	ZVR 20	ZVR 25	ZVR 25	ZVR 25	ZVR 25	ZVR 25	P. 297
Shutter, manual	RS 20	RS 20	RS 20	RS 25	RS 25	RS 25	RS 25	RS 25	P. 299
External grille	MLA 20 MLZ 20	MLA 20 MLZ 20	MLA 20 MLZ 20	MLA 25 MLZ 25	MLA 25 MLZ 25	MLA 25 MLZ 25	MLA 25 MLZ 25	MLA 25 MLZ 25	P. 305
Extension sleeve	VH 20	VH 20	VH 20	VH 25	VH 25	VH 25	VH 25	VH 25	P. 206
Speed controller	ST 1 STU 1	ST 1 STU 1	–	ST 1 STU 1	ST 1 STU 1	ST 1 STU 1	–	–	P. 338
Speed controller, distribution board	–	–	–	STS 2,5	STS 2,5	–	–	–	P. 339
Speed controller, reversing switch	–	STW 1	–	–	STW 1	STW 1	–	–	P. 339
5-step transformer	TRE 0,4-2	TRE 0,6-2	TR 0,4-2	TRE 0,4-2	TRE 0,4-2	TRE 1,6-2	TR 0,4-2	TR 0,4-2	P. 340
5-step transformer, control cabinet	TRE 1,6 S-2	TRE 1,6 S-2	TR 0,8 S-2	TRE 1,6 S-2	TRE 1,6 S-2	TRE 1,6 S-2	TR 0,8 S-2	TR 0,8 S-2	P. 341
5-step switch for TRE...S -2/ TR...S-2 5-step transformer	ESS 20	ESS 20	DSS 20	ESS 20	ESS 20	ESS 20	DSS 20	DSS 20	P. 341
Temperature control system	EAT 6 G/1 EAT 6 TG	EAT 6 G/1 EAT 6 TG	–	EAT 6 G/1 EAT 6 TG	EAT 6 G/1 EAT 6 TG	EAT 6 G/1 EAT 6 TG	–	–	P. 345

	DZQ 25/84 B	DZQ 25/42 B	EZQ 30/6 B	EZQ 30/4 B	EZQ 30/2 B	DZQ 30/6 B	DZQ 30/4 B	DZQ 30/2 B	see
General accessories									
Shutter	AS 25	AS 25	AS 30	AS 30	AS 30	AS 30	AS 30	AS 30	P. 297
Connection frame	ZVR 25	ZVR 25	ZVR 30	ZVR 30	ZVR 30	ZVR 30	ZVR 30	ZVR 30	P. 297
Shutter, manual	RS 25	RS 25	RS 30	RS 30	RS 30	RS 30	RS 30	RS 30	P. 299
External grille	MLA 25 MLZ 25	MLA 25 MLZ 25	MLA 30 MLZ 30	MLA 30 MLZ 30	MLA 30 MLZ 30	MLA 30 MLZ 30	MLA 30 MLZ 30	MLA 30 MLZ 30	P. 305
Extension sleeve	VH 25	VH 25	VH 30	VH 30	VH 30	VH 30	VH 30	VH 30	P. 206
Pole-changing switch	P 1	P 1	–	–	–	–	–	–	P. 335
Speed controller	–	–	ST 1 STU 1	ST 1 STU 1	ST 2,5 STU 2,5	–	–	–	P. 338
Speed controller, distribution board	–	–	–	–	STS 2,5	–	–	–	P. 339
Speed controller, reversing switch	–	–	STW 1	STW 1	STW 2,5	–	–	–	P. 339
5-step transformer	–	–	TRE 0,4-2	TRE 0,6-2	TRE 3,3-2	TR 0,4-2	TR 0,4-2	TR 2,5-2	P. 340
5-step transformer, control cabinet	–	–	TRE 1,6 S-2	TRE 1,6 S-2	TRE 3,3 S-2	TR 0,8 S-2	TR 0,8 S-2	TR 2,5 S-2	P. 341
5-step switch for TRE...S -2/ TR...S-2 5-step transformer	–	–	ESS 20	ESS 20	ESS 20	DSS 20	DSS 20	DSS 20	P. 341
Temperature control system	–	–	EAT 6 G/1 EAT 6 TG	EAT 6 G/1 EAT 6 TG	EAT 6 G/1 EAT 6 TG	–	–	–	P. 345

	DZQ 30/84 B	DZQ 30/42 B	EZQ 35/6 B	EZQ 35/4 B	DZQ 35/6 B	DZQ 35/4 B	DZQ 35/2 B	DZQ 35/84 B	see
General accessories									
Shutter	AS 30	AS 30	AS 35	AS 35	AS 35	AS 35	AS 35	AS 35	P. 297
Connection frame	ZVR 30	ZVR 30	ZVR 35	ZVR 35	ZVR 35	ZVR 35	ZVR 35	ZVR 35	P. 297
Shutter, manual	RS 30	RS 30	RS 35	RS 35	RS 35	RS 35	RS 35	RS 35	P. 299
External grille	MLA 30 MLZ 30	MLA 30 MLZ 30	MLA 35 MLZ 35	MLA 35 MLZ 35	MLA 35 MLZ 35	MLA 35 MLZ 35	MLA 35 MLZ 35	MLA 35 MLZ 35	P. 305
Extension sleeve	VH 30	VH 30	VH 35	VH 35	VH 35	VH 35	VH 35	VH 35	P. 206
Pole-changing switch	P 1	P 1	–	–	–	–	–	P 1	P. 335
Speed controller	–	–	ST 1 STU 1	ST 1 STU 1	–	–	–	–	P. 338
Speed controller, reversing switch	–	–	STW 1	STW 1	–	–	–	–	P. 339
5-step transformer	–	–	TRE 0,4-2	TRE 1,6-2	TR 0,4-2	TR 0,4-2	TR 2,5-2	–	P. 340
5-step transformer, control cabinet	–	–	TRE 1,6 S-2	TRE 1,6 S-2	TR 0,8 S-2	TR 0,8 S-2	TR 2,5 S-2	–	P. 341
5-step switch for TRE...S -2/ TR...S-2 5-step transformer	–	–	ESS 20	ESS 20	DSS 20	DSS 20	DSS 20	–	P. 341
Temperature control system	–	–	EAT 6 G/1 EAT 6 TG	EAT 6 G/1 EAT 6 TG	–	–	–	–	P. 345

Accessories selection table

	DZQ 35/42 B	EZQ 40/6 B	EZQ 40/4 B	DZQ 40/8 B	DZQ 40/6 B	DZQ 40/4 B	DZQ 40/2 B	DZQ 40/84 B	see
General accessories									
Shutter	AS 35	AS 40	AS 40	AS 40	AS 40	AS 40	AS 40	AS 40	P. 297
Connection frame	ZVR 35	ZVR 40	ZVR 40	ZVR 40	ZVR 40	ZVR 40	ZVR 40	ZVR 40	P. 297
Shutter, manual	RS 35	RS 40	RS 40	RS 40	RS 40	RS 40	RS 40	RS 40	P. 299
External grille	MLA 35 MLZ 35	MLA 40 MLZ 40	MLA 40 MLZ 40	MLA 40 MLZ 40	MLA 40 MLZ 40	MLA 40 MLZ 40	MLA 40 MLZ 40	MLA 40 MLZ 40	P. 305
Extension sleeve	VH 35	VH 40	VH 40	VH 40	VH 40	VH 40	VH 40	VH 40	P. 206
Pole-changing switch	P 1	–	–	–	–	–	–	P 1	P. 335
Speed controller	–	ST 1 STU 1	ST 2,5 STU 2,5	–	–	–	–	–	P. 338
Speed controller, reversing switch	–	STW 1	STW 2,5	–	–	–	–	–	P. 339
5-step transformer	–	TRE 0,6-2	TRE 1,6-2	TR 0,4-2	TR 0,4-2	TR 0,8-2	–	–	P. 340
5-step transformer, control cabinet	–	TRE 1,6 S-2	TRE 1,6 S-2	TR 0,8 S-2	TR 0,8 S-2	TR 0,8 S-2	–	–	P. 341
5-step switch for TRE...S -2/ TR...S-2 5-step transformer	–	ESS 20	ESS 20	DSS 20	DSS 20	DSS 20	–	–	P. 341
Temperature control system	–	EAT 6 G/1 EAT 6 TG	EAT 6 G/1 EAT 6 TG	–	–	–	–	–	P. 345

	DZQ 40/42 B	EZQ 45/6 B	EZQ 45/4 B	DZQ 45/6 B	DZQ 45/4 B	EZQ 50/8 B	EZQ 50/6 B	DZQ 50/6 B	see
General accessories									
Shutter	AS 40	AS 45	AS 45	AS 45	AS 45	AS 50	AS 50	AS 50	P. 297
Connection frame	ZVR 40	ZVR 45	ZVR 45	ZVR 45	ZVR 45	ZVR 50	ZVR 50	ZVR 50	P. 297
Shutter, manual	RS 40	RS 45	RS 45	RS 45	RS 45	RS 50	RS 50	RS 50	P. 299
External grille	MLA 40 MLZ 40	–	–	–	–	MLA 50 MLZ 50	MLA 50 MLZ 50	MLA 50 MLZ 50	P. 305
Extension sleeve	VH 40	VH 45	VH 45	VH 45	VH 45	VH 50	VH 50	VH 50	P. 206
Pole-changing switch	P 1	–	–	–	–	–	–	–	P. 335
Speed controller	–	ST 2,5 STU 2,5	ST 2,5 STU 2,5	–	–	ST 1 STU 1	ST 2,5 STU 2,5	–	P. 338
Speed controller, distribution board	–	STS 2,5	STS 2,5	–	–	–	–	–	P. 339
Speed controller, reversing switch	–	STW 2,5	STW 2,5	–	–	STW 1	STW 2,5	–	P. 339
5-step transformer	–	–	TRE 3,3-2	TR 0,8-2	TR 2,5-2	TRE 0,6-2	TRE 1,6-2	TR 0,8-2	P. 340
5-step transformer, control cabinet	–	–	TRE 3,3 S-2	TR 0,8 S-2	TR 2,5 S-2	TRE 1,6 S-2	TRE 1,6 S-2	TR 0,8 S-2	P. 341
5-step switch for TRE...S -2/ TR...S-2 5-step transformer	–	–	ESS 20	DSS 20	DSS 20	ESS 20	ESS 20	DSS 20	P. 341
Temperature control system	–	EAT 6 G/1 EAT 6 TG	EAT 6 G/1 EAT 6 TG	–	–	EAT 6 G/1 EAT 6 TG	EAT 6 G/1 EAT 6 TG	–	P. 345

	DZQ 50/4 B	DZQ 50/84 B	DZQ 56/6 B	DZQ 56/4 B	DZQ 60/8 B	DZQ 60/6 B	DZQ 60/4 B	DZQ 60/84 B	see
General accessories									
Shutter	AS 50	AS 50	AS 60	AS 60	AS 60	AS 60	AS 60	AS 60	P. 297
Connection frame	ZVR 50	ZVR 50	ZVR 56	ZVR 56	ZVR 60	ZVR 60	ZVR 60	ZVR 60	P. 297
Shutter, manual	RS 50	RS 50	RS 60	RS 60	RS 60	RS 60	RS 60	RS 60	P. 299
External grille	MLA 50 MLZ 50	MLA 50 MLZ 50	–	–	–	–	–	–	P. 305
Extension sleeve	VH 50	VH 50	–	–	–	–	–	–	P. 206
Pole-changing switch	–	P 1	–	–	–	–	–	P 1	P. 335
5-step transformer	TR 2,5-2	–	TR 2,5-2	TR 6,6-2	TR 2,5-2	TR 2,5-2	TR 6,6-2	–	P. 340
5-step transformer, control cabinet	TR 2,5 S-2	–	TR 2,5 S-2	TR 6,6 S-2	TR 2,5 S-2	TR 2,5 S-2	TR 6,6 S-2	–	P. 341
5-step switch for TRE...S -2/ TR...S-2 5-step transformer	DSS 20	–	DSS 20	DSS 20	DSS 20	DSS 20	DSS 20	–	P. 341



Features

- Explosion protection in accordance with ATEX.
- Ex II 2G Ex e IIB+H₂ T3/T4 Gb.
- For usage temperatures of -20°C ≤ Ta ≤ +40°C.
- MAICO Ex fans fulfil the safety requirements of European Directive 2014/34/EU for units and protective systems in explosion-endangered areas.
- For zones 1 and 2.
- Model series
 - EZQ...-Ex, DZQ...-Ex with square wall plates.
 - EZS...-Ex, DZS...-Ex with steel wall rings.
- Protective grille on the intake side, yellow chromated, protection against accidental contact in accordance with DIN EN ISO 13857.
- Can be fitted in any position.

Electrical connection

- EZQ/EZS 20 E Ex e: Connecting cable, approx. 0.5 m long.
- DZQ/DZS ... Ex e: Connecting cable, approx. 1.7 m long.
- Separate terminal box, explosion proof, with cable screw-connections.

AC motor

- Non-reversible.
- No speed control allowed.
- Guarantee overload protection with MAICO MVEx 0.4 motor protection switch.

Three-phase AC motor

- Separate terminal box, explosion proof, with cable screw-connections.
- Reversible.
- Reversing mode: The volumetric flow is reduced by approx. 35 % with abnormal air flow direction.
- Speed control permitted with transformer TR.... Exception: DZ.. 35/2 B Ex e
- The temperature in the fan unit is monitored by PTC thermistors. The PTC thermistors must be connected to a triggering system (safety device according to Directive 2014/34/EU), that separates the fan permanently from the power if the temperature gets too hot.
- The MAICO PTC thermistor triggering device MVS 6 or TMS is recommended as the triggering system.

EZQ/EZS 20 E Ex e required safety technology

- A motor protection switch is needed to fuse the EZQ/EZS-Ex units.
- Maico provides the MVEx 0.4 motor protection switch to monitor the motor current for this purpose.



DZQ/DZS-Ex required safety technology

- A PTC thermistor triggering device is needed to fuse the DZQ/DZS-Ex units.
- Maico provides the MVS 6 PTC thermistor triggering device and TMS for this purpose.
- MVS 6 PTC thermistor triggering device
 - Independent complete system.
 - For monitoring the maximum motor temperature.
 - Type-examination tested according to Directive 2014/34/EU (ATEX).
 - Installation exclusively in non-explosive areas.

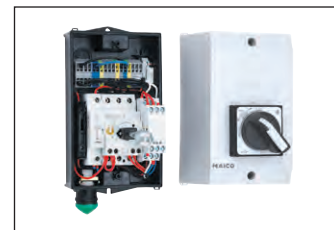

- TMS PTC thermistor triggering device
 - For monitoring the maximum motor temperature.
 - Suitable for installation in control cabinets.
 - Type-examination tested according to Directive 2014/34/EU (ATEX).
 - Installation exclusively in non-explosive areas.



Special versions

- Special voltages are available as special versions on request, at an extra cost.
- Information on operation at temperatures occasionally below -20°C available upon request.
- Feasibility must be checked in each case.



Technical data

Article	Art. No.	U _{nom}	f _{nom}	Air flow volume	Rotating speed	P _{nom}	I _{nom}	Sound power level L _{WA7} dB(A)	Degree of protection	Temperature class	Insulation class	Weight
		V	Hz	m ³ /h	1/min	W	A		IP			kg
DN 200												
EZQ 20/4 E Ex e	0083.0850	230	50	440	1,340	45	0.32	57	54	T3	B	4
DZQ 20/4 B Ex e	0083.0170	400	50	540	1,490	30	0.19	59	54	T4	F	7.1
DZQ 20/2 B Ex e	0083.0171	400	50	1,090	2,950	65	0.23	75	54	T4	F	7.1
DN 250												
DZQ 25/4 B Ex e	0083.0172	400	50	950	1,475	38	0.19	65	54	T4	F	7.6
DZQ 25/2 B Ex e	0083.0173	400	50	1,880	2,880	130	0.28	81	54	T4	F	7.1
DN 300												
DZQ 30/6 B Ex e	0083.0174	400	50	1,100	985	25	0.12	60	54	T4	F	12
DZQ 30/4 B Ex e	0083.0175	400	50	1,730	1,475	95	0.48	69	54	T3	F	9.4
DZQ 30/2 B Ex e	0083.0176	400	50	3,380	2,910	240	0.46	86	54	T3	F	12.5
DN 350												
DZQ 35/6 B Ex e	0083.0177	400	50	1,750	970	35	0.13	64	54	T4	F	13.3
DZQ 35/4 B Ex e	0083.0178	400	50	2,660	1,455	125	0.49	72	54	T3	F	10.6
DZQ 35/2 B Ex e	0083.0179	400	50	5,460	2,900	580	1.3	90	54	T3	F	13.7
DN 400												
DZQ 40/6 B Ex e	0083.0180	400	50	2,740	985	95	0.54	68	54	T4	F	14.7
DZQ 40/4 B Ex e	0083.0181	400	50	4,130	1,465	170	0.55	77	54	T4	F	14.9
DN 450												
DZQ 45/6 B Ex e	0083.0182	400	50	4,240	970	140	0.56	72	54	T4	F	16.1
DZQ 45/4 B Ex e	0083.0183	400	50	6,400	1,425	330	0.7	82	54	T4	F	16.5
DN 500												
DZQ 50/6 B Ex e	0083.0184	400	50	5,320	960	165	0.56	73	54	T4	F	18.4
DZQ 50/4 B Ex e	0083.0185	400	50	8,200	1,440	420	0.82	82	54	T3	F	24.1
DN 600												
DZQ 60/6 B Ex e	0083.0186	400	50	9,450	960	295	0.66	78	54	T3	F	27.3

EZS-Ex/DZS-Ex models fans are also available with a round steel wall ring instead of EZQ-Ex/DZQ-Ex models with square wall plates (Exception: nominal sizes DN 450). Technical data, prices and accessories are the same as for EZQ/DZQ model series. Delivery times on request.

Dimensions [mm]

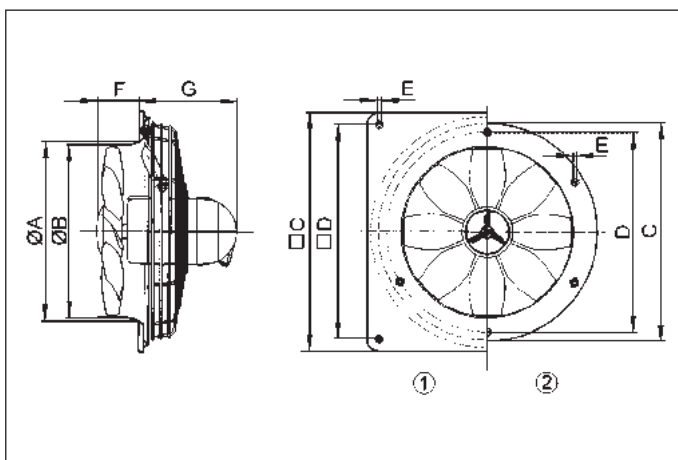

① Steel wall plate = EZQ-Ex/DZQ-Ex model
② Steel wall ring = EZS-Ex/DZS-Ex model

Nominal size	A	B	C	D	E	F	G max
DN 200 EZQ-Ex/DZQ-Ex	216.7	215	345	305	8.5	44.5	176
DN 200 EZS-Ex/DZS-Ex	218.9	215	297	250	10.4	60	176
DN 250 DZQ-Ex	271.1	265	400	350	8.5	57.5	165
DN 250 DZS-Ex	271.6	263	353	306	10.4	80	165
DN 300 DZQ-Ex	326.9	315	465	405	11	72.5	183
DN 300 DZS-Ex	330.4	313	420	370	10.4	95	183
DN 350 DZQ-Ex	380.5	365	525	465	11	90.5	198
DN 350 DZS-Ex	386.6	364	476	428	10.4	95	198
DN 400 DZQ-Ex	430.8	417	580	520	11	100	172
DN 400 DZS-Ex	442.6	414	533	485	10.4	109	172
DN 450 DZQ-Ex	470	461	630	570	11	107	162
DN 500 DZQ-Ex	542.7	516	700	640	11	137	156.5
DN 500 DZS-Ex	556.1	514	650	602	10.4	138	156.5
DN 600 DZQ-Ex	652.2	615	820	740	11	140	177.5
DN 600 DZS-Ex	666.9	614	772	724	10.4	138	177.5

Characteristic curves for DN 200 and DN 250

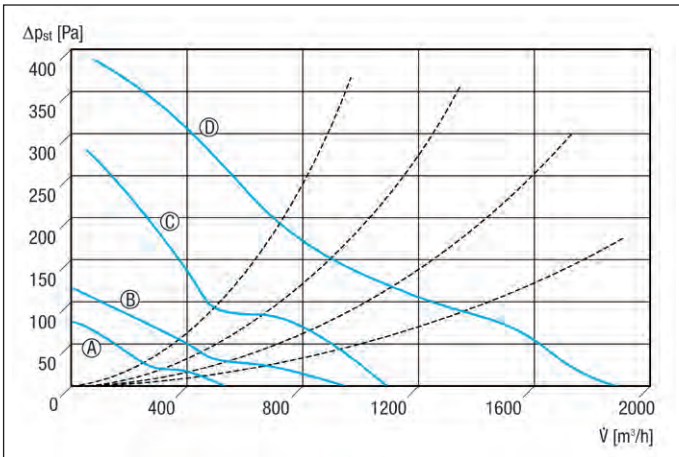

- Ⓐ EZQ 20/4 E Ex e, DZQ 20/4 B Ex e
- Ⓑ DZQ 25/4 B Ex e
- Ⓒ DZQ 20/2 B Ex e
- Ⓓ DZQ 25/2 B Ex e

Characteristic curves for DN 300 and DN 350

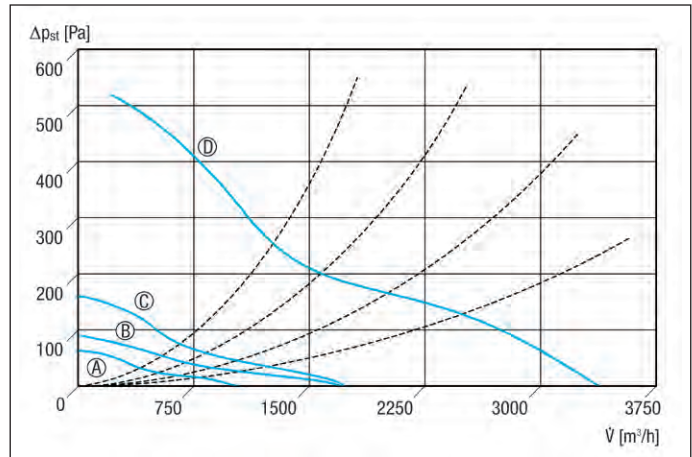

- Ⓐ DZQ 30/6 B Ex e
- Ⓑ DZQ 35/6 B Ex e
- Ⓒ DZQ 30/4 B Ex e
- Ⓓ DZQ 30/2 B Ex e

Characteristic curves for DN 350 and DN 400

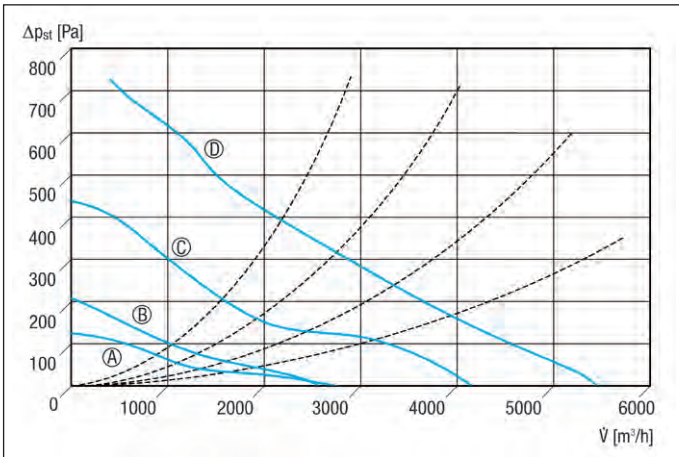

- Ⓐ DZQ 40/6 B Ex e
- Ⓑ DZQ 35/4 B Ex e
- Ⓒ DZQ 40/4 B Ex e
- Ⓓ DZQ 35/2 B Ex e

Characteristic curves for DN 450, DN 500 and DN 600

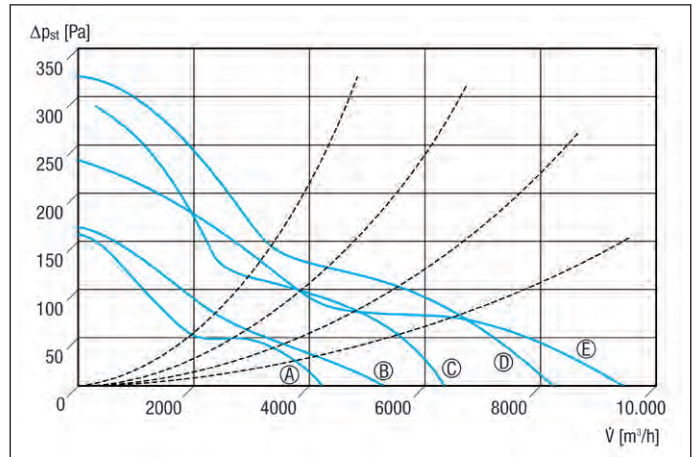

- Ⓐ DZQ 45/6 B Ex e
- Ⓑ DZQ 50/6 B Ex e
- Ⓒ DZQ 45/4 B Ex e
- Ⓓ DZQ 50/4 B Ex e
- Ⓔ DZQ 60/6 B Ex e

Accessories selection table

	EZQ 20/4 E Ex e	DZQ 20/4 B Ex e	DZQ 20/2 B Ex e	DZQ 25/4 B Ex e	DZQ 25/2 B Ex e	DZQ 30/6 B Ex e	DZQ 30/4 B Ex e	DZQ 30/2 B Ex e	DZQ 35/6 B Ex e	see
Specific accessories										
PTC thermistor triggering device	–	MVS 6	MVS 6	MVS 6	MVS 6	MVS 6	MVS 6	MVS 6	MVS 6	P. 336
Machine protection relay thermistor	–	TMS	TMS	TMS	TMS	TMS	TMS	TMS	TMS	P. 336
Motor protection switch	MVEx 0,4	–	–	–	–	–	–	–	–	P. 337
General accessories										
Shutter	AS 20	AS 20	AS 20	AS 25	AS 25	AS 30	AS 30	AS 30	AS 35	P. 297
Connection frame	ZVR 20	ZVR 20	ZVR 20	ZVR 25	ZVR 25	ZVR 30	ZVR 30	ZVR 30	ZVR 35	P. 297
Extension sleeve	VH 20	VH 20	VH 20	VH 25	VH 25	VH 30	VH 30	VH 30	VH 35	P. 206
5-step transformer	–	TR 0,4-2	TR 0,4-2	TR 0,4-2	TR 0,4-2	TR 0,8-2	TR 0,8-2	TR 2,5-2	TR 0,8-2	P. 340
5-step transformer, control cabinet	–	TR 0,8 S-2	TR 0,8 S-2	TR 0,8 S-2	TR 0,8 S-2	TR 0,8 S-2	TR 0,8 S-2	TR 2,5 S-2	TR 0,8 S-2	P. 341
5-step switch for TRE...S -2/ TR...S-2 5-step transformer	–	DSS 20	DSS 20	DSS 20	DSS 20	DSS 20	DSS 20	DSS 20	DSS 20	P. 341

	DZQ 35/4 B Ex e	DZQ 35/2 B Ex e	DZQ 40/6 B Ex e	DZQ 40/4 B Ex e	DZQ 45/6 B Ex e	DZQ 45/4 B Ex e	DZQ 50/6 B Ex e	DZQ 50/4 B Ex e	DZQ 60/6 B Ex e	see
Specific accessories										
PTC thermistor triggering device	MVS 6	MVS 6	MVS 6	MVS 6	MVS 6	MVS 6	MVS 6	MVS 6	MVS 6	P. 336
Machine protection relay thermistor	TMS	TMS	TMS	TMS	TMS	TMS	TMS	TMS	TMS	P. 336
General accessories										
Shutter	AS 35	AS 35	AS 40	AS 40	AS 45	AS 45	AS 50	AS 50	AS 60	P. 297
Connection frame	ZVR 35	ZVR 35	ZVR 40	ZVR 40	ZVR 45	ZVR 45	ZVR 50	ZVR 50	ZVR 60	P. 297
Extension sleeve	VH 35	VH 35	VH 40	VH 40	VH 45	VH 45	VH 50	VH 50	–	P. 206
5-step transformer	TR 0,8-2	–	TR 0,8-2	TR 0,8-2	TR 0,8-2	TR 0,8-2	TR 0,8-2	TR 2,5-2	TR 0,8-2	P. 340
5-step transformer, control cabinet	TR 0,8 S-2	–	TR 0,8 S-2	TR 0,8 S-2	TR 0,8 S-2	TR 0,8 S-2	TR 0,8 S-2	TR 2,5 S-2	TR 0,8 S-2	P. 341
5-step switch for TRE...S -2/ TR...S-2 5-step transformer	DSS 20	–	DSS 20	DSS 20	DSS 20	DSS 20	DSS 20	DSS 20	DSS 20	P. 341



Features

- 8- to 10-blade impellers made of synthetic material. Dynamically balanced, in accordance with performance level 6.3, DIN ISO 1940.
- High degree of protection IP 55.
- Simple installation using wall ring.
- Protective grille on the intake side, varnished.

Air flow direction

- For air extraction (clockwise rotation) only.

Motor

- Not suitable for ventilating steam-saturated air.
- Overload protection guaranteed by motor protection switch to be provided by customer.
- Speed control with MFU frequency converter.
- Insulation class F.

Electrical connection

- In the terminal box on the motor.

Safety instructions

- A star / delta switch, to be supplied by the customer, must be used with fans with power consumption > 4 kW, in order to limit the starting current.
- The fan may be operated only if the protection against accidental contact with the impeller is guaranteed to be in accordance with DIN EN ISO 13857.
- Not controllable with transformer.

Technical data for units > 125 W according to ErP in Best Efficiency Point (BEP)

Article	Art. No.	U _{nom} V	f _{nom} Hz	Air flow volume m ³ /h	Sound power level _{WA7} dB(A)	Air volume _{nom} m ³ /h	Pressure p _{fs, nom} Pa	Rotating speed n _{nom} 1/min	P _{nom} W	I _{nom} A	I _{max} A	T _{max} at I _{max} °C	Weight kg	Efficiency level N	Total efficiency η %
DAS 71/4	0083.0853	400	50	20,000	82	12,300 ¹⁾	211 ¹⁾	1,460 ¹⁾	1,732 ¹⁾	4.1 ¹⁾	5.3	50	46.5	46	41.5
DAS 80/4	0083.0856	400	50	28,000	94	19,600 ¹⁾	443 ¹⁾	1,470 ¹⁾	4,001 ¹⁾	7.3 ¹⁾	9.4	50	64	63	60.2
DAS 90/4	0083.0859	400	50	45,000	98	22,300 ¹⁾	591 ¹⁾	1,480 ¹⁾	5,945 ¹⁾	11.8 ¹⁾	15.4	50	100	63	62
DAS 100/4	0083.0862	400	50	69,000	98	19,500 ¹⁾	892 ¹⁾	1,480 ¹⁾	7,718	14.8 ¹⁾	17.5	50	132	64	63
DAS 112/6	0083.0864	400	50	63,000	93	48,800 ¹⁾	350 ¹⁾	960 ¹⁾	6,002 ¹⁾	11.1 ¹⁾	13.5	50	133	39	37.8
DAS 125/6	0083.0866	400	50	72,000	96	57,200 ¹⁾	383 ¹⁾	970 ¹⁾	7,497 ¹⁾	14.1 ¹⁾	17	50	175	40	38.7

¹⁾ In opt. efficiency

BEP measured in measurement category C, static efficiency category. For further ErP data, see www.maico-fans.com.

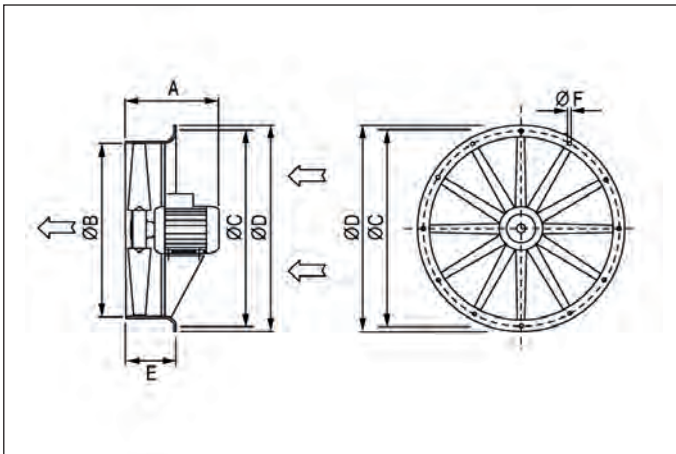
Dimensions [mm]

Number of holes:

16 with DN 710, DN 800, DN 900 or 20 with DN 1000, DN 1120 and DN 1250

Article	A	B	C	D	E	F
DAS 71/4	500	710	860	910	230	12
DAS 80/4	510	810	970	1,030	250	16
DAS 90/4	655	910	1,070	1,130	300	16
DAS 100/4	655	1,010	1,190	1,250	300	16
DAS 112/6	655	1,130	1,320	1,380	300	16
DAS 125/6	745	1,260	1,470	1,530	300	16

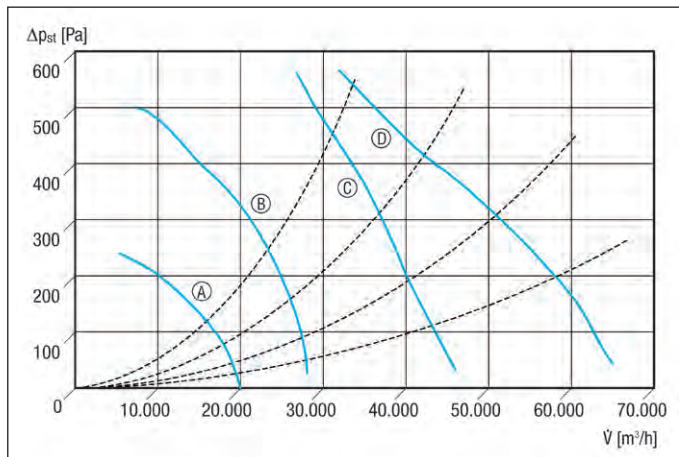
Characteristic curves for DN 710, DN 800, DN 900, DN 1000

Ⓐ DAS 71/4
 Ⓑ DAS 80/4
 Ⓒ DAS 90/4
 Ⓓ DAS 100/4

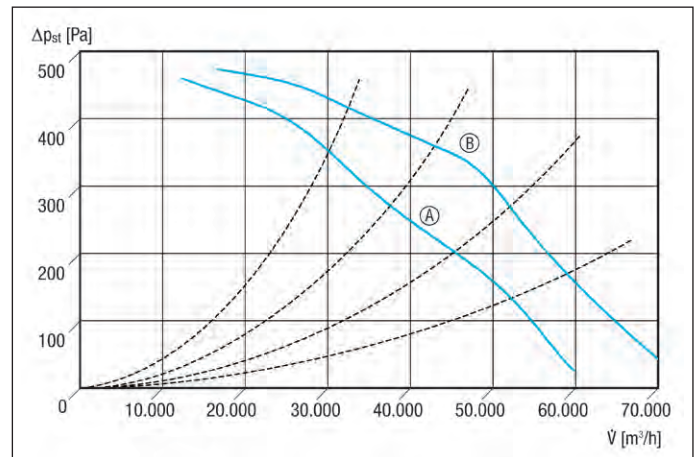
Characteristic curves for DN 1125, DN 1250

Ⓐ DAS 112/6
 Ⓑ DAS 125/6

Accessories selection table

	DAS 71/4	DAS 80/4	DAS 90/4	DAS 100/4	DAS 112/6	DAS 125/6	see
Specific accessories							
Square wall plate	QW 71	QW 80	QW 90	QW 100	QW 112	QW 125	P. 206
General accessories							
Shutter	ARP 71	ARP 80	ARP 100	ARP 100	–	–	P. 298
Frequency converter	MFU 4	MFU 14	MFU 19	–	MFU 14	MFU 19	P. 339

**Square wall plates
QW**



- Wall plate for the installation of DAS fans.

Dimensions [mm]

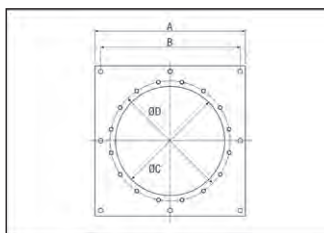

Wall plate width approx. 5 mm.

Common features

Material	Steel, varnished
Installation site	Wall

Article	Art. No.	Nominal size mm
QW 71	0053.0013	710
QW 80	0053.0014	800
QW 90	0053.0015	900
QW 100	0053.0016	1,000
QW 112	0053.0017	1,125
QW 125	0053.0018	1,250

Article	A mm	B mm	C mm	D mm
QW 71	1,120	1,020	830	860
QW 80	1,210	1,110	940	970
QW 90	1,320	1,210	1,040	1,070
QW 100	1,420	1,320	1,140	1,190
QW 112	1,570	1,470	1,270	1,320
QW 125	1,720	1,620	1,420	1,470

**Extension sleeves
VH**



- Extension sleeve for wall and roof installations.

Dimensions [mm]

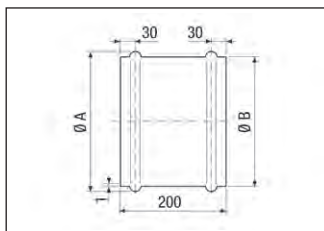

Common features

Material	Sheet steel, galvanised
Installation site	Wall/Ceiling

Article	Art. No.	Nominal size mm
VH 20	0055.0030	200
VH 25	0055.0031	250
VH 30	0055.0032	300
VH 31	0055.0037	315
VH 35	0055.0033	350
VH 40	0055.0034	400
VH 45	0055.0036	450
VH 50	0055.0035	500

Article	A mm	B mm
VH 20	226	219
VH 25	276	269
VH 30	326	319
VH 31	342	335
VH 35	376	369
VH 40	426	419
VH 45	471	467
VH 50	526	522

**Air filters
ZFF**

- Air filter for cleaning the fresh air supply.
- With finger guard.
- Easy filter change.
- Accessories: FF.. spare air filter .

Dimensions [mm]

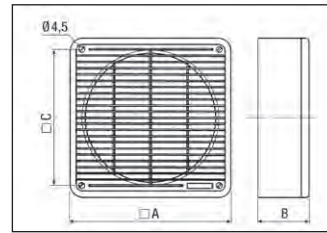
Common features

Filter class	G2
Material	Synthetic material
Colour	Pearl white, similar to RAL 1013

Article	Art. No.	Nominal size mm
ZFF 20	0149.0001	200
ZFF 30	0149.0003	250/300
ZFF 40	0149.0005	350/400

Article	A mm	B mm	C mm
ZFF 20	258	82	212
ZFF 30	365	92	319
ZFF 40	470	112	423

**Air filters, replacement
FF**

Article	Art. No.	Nominal size mm
FF 20	0093.0230	200
FF 30	0093.0232	250/300
FF 40	0093.0234	350/400

- Replacement filter for ZFF air filter.

Article	Width mm	Height mm	Depth mm
FF 20	298	255	6
FF 30	405	355	6
FF 40	510	465	6

Common features

Filter class	G2
Packing unit	3 pieces

Axial high-performance duct fans

Example illustration of a ventilation installation

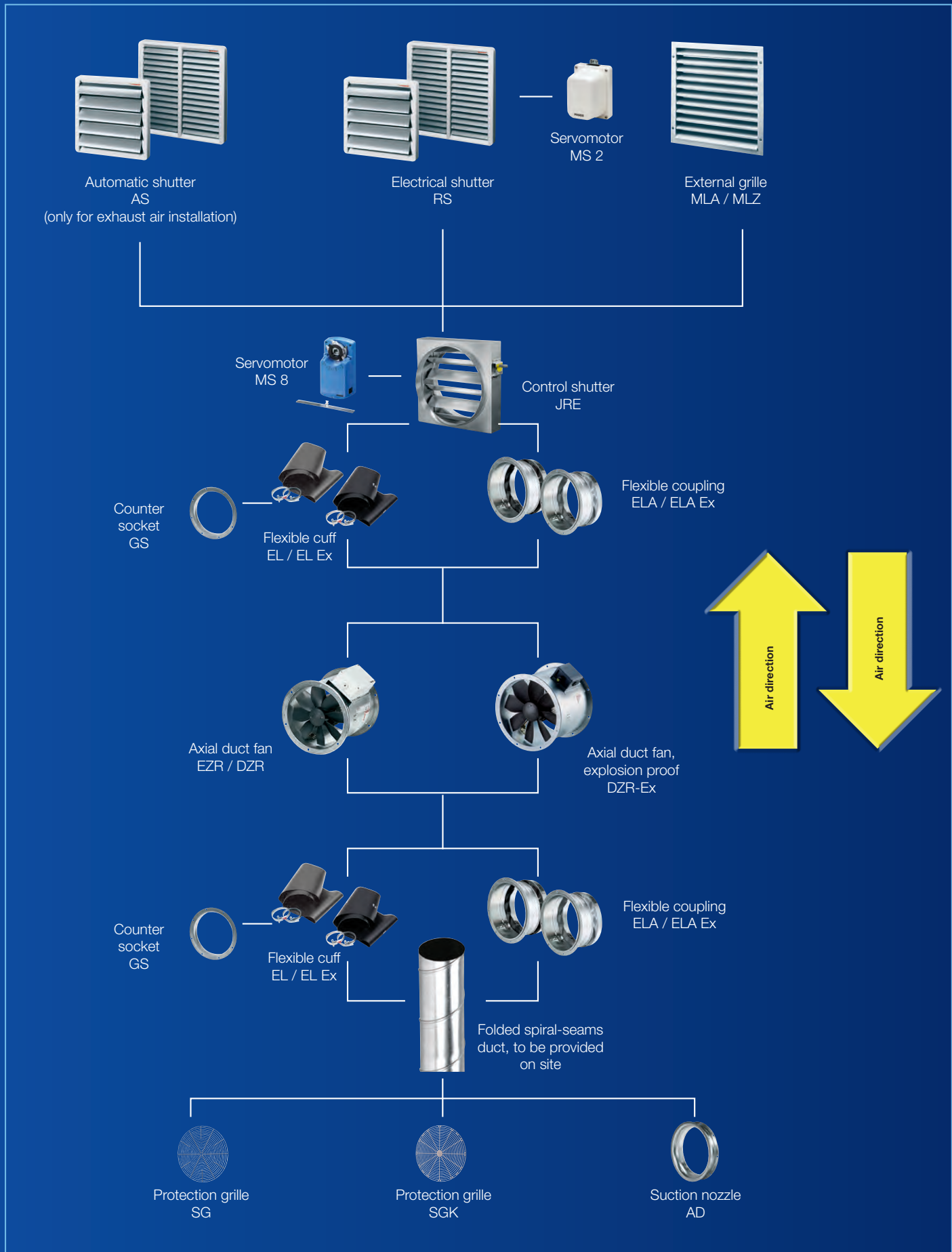

EZR, DZR duct fans

Up to 15,310 m³/h



Page 210

DZR duct fan, explosion proof

Up to 9,370 m³/h



Page 216

Accessories

Mounting feet, vibration dampers,
flexible cuffs, protective grilles, shutters, etc.



Page 219



Features

- Duct sleeve made of galvanised sheet steel, with flanges on both sides.
- 8-blade impellers made of glass-fibre filled polyamide. Dynamically balanced at two levels, in accordance with performance level 6.3, DIN ISO 1940, Part 1.
- Flange holes in accordance with DIN EN 12220:1998.
- DZR 56/6 B and DZR 56/4 B: Flange holes in accordance with DIN EN 12220:1998.
- To avoid transmission of vibrations to the duct system: Use flexible couplings, feet and vibration dampers.
- High degree of protection IP 55. Exception EZR/DZR... D IP 54.
- Can be fitted in any position.

Motor

- Asynchronous motor, speed controllable. Exception: Type DZR 40/2 B.
- Not suitable for ventilating steam-saturated air.
- Air flow direction is indicated on the unit with direction of rotation and air flow direction arrows.
- Reversing mode: The volumetric flow is reduced by approx. 35 % with abnormal air flow direction.

AC motor

- EZR model series.
- Rated voltage 230 V, 50 Hz.
- Capacitor motors with operating capacitor ready for use in terminal box.
- Thermal overload protection as a standard feature.
- Potential-free terminal connections, which must be connected to e.g. an MVE 10 full on motor protection switch (not suitable for EZR 25/4 D, EZR 30/6 B and EZR 35/6 B) or the control circuit of a contactor.

Three-phase AC motor

- DZR model series.
- Rated voltage 400 V, 50 Hz.
- Thermal overload protection as a standard feature. Exception: available on request for DZR 25/4 D and pole-changeable axial duct fans. Potential-free terminal connections, which must be connected to e.g. an MV 25 protective motor switch or the control circuit of a contactor.
- Pole-changeable fans: Ensure overload protection is guaranteed by a motor protection switch provided by the customer.

Electrical connection

- Terminal box with cable sleeves fitted on the outside.

Safety instructions

- The fan may be operated only if the protection against accidental contact with the impeller is guaranteed to be in accordance with DIN EN 13857.

Special versions

- The following special versions are available on request, at an extra cost:
 - Special voltages and frequencies.
 - PTC thermistor, potential-free terminal connection.
 - Condensation drainage holes.
 - Fans with enhanced anti-corrosion protection.
 - Impellers made of aluminium.
- Information on operation at temperatures occasionally below -20°C available upon request.
- If operating with frequency converters, the factory must be consulted.
- Feasibility must be checked in each case.

Technical data for units < 125 W

Article	Art. No.	U _{nom} V	f _{nom} Hz	Air flow volume m ³ /h	Rotating speed 1/min	P _{nom} W	I _{nom} A	I _{max} A	T _{max} at I _{max} °C	Sound power level L _{WA5} dB(A)	Insulation class	Weight kg	Pole-changeable
DN 200													
EZR 20/2 B	0086.0000	230	50	1,100	2,850	65	0.3	0.51	60	76	B	5.9	-
DZR 20/2 B	0086.0020	400	50	1,100	2,850	75	0.2	0.25	60	75	B	6	-
DN 250													
EZR 25/4 D	0086.0487	230	50	1,000	1,425	32	0.16	0.19	60	61	B	5.8	-
DZR 25/4 D	0086.0490	400	50	1,100	1,425	50	0.15	0.16	40	61	B	5.7	-
DZR 25/84 B	0086.0040	400	50	500/1,100	715/1,425	40/80	0.1/0.3	0.1/0.3	60	46/62	B	7.3	✓
DN 300													
EZR 30/6 B	0086.0003	230	50	1,200	930	59	0.3	0.32	60	59	B	8.4	-
EZR 30/4 B	0086.0004	230	50	1,800	1,425	90	0.41	0.51	60	68	B	8.5	-
DZR 30/6 B	0086.0023	400	50	1,200	930	70	0.17	0.19	60	59	B	8.4	-
DZR 30/4 B	0086.0024	400	50	1,800	1,425	80	0.3	0.33	60	68	B	8.5	-
DZR 30/84 B	0086.0042	400	50	900/1,800	715/1,425	40/100	0.1/0.3	0.1/0.3	60	56/67	B	8.4	✓
DN 350													
EZR 35/6 B	0086.0006	230	50	1,800	930	65	0.32	0.35	60	61	B	9.3	-
EZR 35/4 B	0086.0007	230	50	2,800	1,425	115	0.55	0.75	60	72	B	9.4	-
DZR 35/6 B	0086.0026	400	50	1,800	930	75	0.17	0.17	60	60	B	9.6	-
DZR 35/4 B	0086.0027	400	50	2,800	1,425	120	0.3	0.38	60	72	B	9.4	-
DN 400													
EZR 40/6 B	0086.0008	230	50	2,600	930	98	0.46	0.52	55	63	B	11.6	-
DZR 40/6 B	0086.0029	400	50	2,680	930	110	0.3	0.3	60	64	B	11.6	-
DN 500													
EZR 50/8 B	0086.0012	230	50	4,100	715	110	0.5	0.65	60	75	B	16.4	-

Technical data for units > 125 W according to ErP in Best Efficiency Point (BEP)

Article	Art. No.	U _{nom} V	f _{nom} Hz	Air flow volume m ³ /h	Sound power level L _{WAS} dB(A)	Air volume _{nom} m ³ /h	Pressure P _{is, nom} Pa	Speed n _{nom} 1/min	P _{nom} W	I _{nom} A	I _{max} A	T _{max} at I _{max} °C	Weight kg	Efficiency level N	Total efficiency η %
DN 250															
EZR 25/2 B	0086.0002	230	50	2,200	78	1,610 ¹⁾	160 ¹⁾	2,930 ¹⁾	195 ¹⁾	1 ¹⁾	1.2	60	9.3	58.4	47.5
DZR 25/2 B	0086.0022	400	50	2,190	82	1,580 ¹⁾	137 ¹⁾	2,280 ¹⁾	175 ¹⁾	0.35 ¹⁾	0.4	60	9.3	58.2	46.9
DN 300															
EZR 30/2 B	0086.0005	230	50	3,690	83	2,660 ¹⁾	165 ¹⁾	2,830 ¹⁾	350 ¹⁾	1.6 ¹⁾	2.4	60	12.08	60.4	51
DZR 30/2 B	0086.0025	400	50	3,670	88	2,650 ¹⁾	168 ¹⁾	2,865 ¹⁾	360 ¹⁾	0.8 ¹⁾	1	60	12.9	58.8	49.3
DZR 30/42 B	0086.0044	400	50	1,890/3,870	67/89	1,410/2,730 ¹⁾	40/180 ¹⁾	1,450/2,830 ¹⁾	70/405 ¹⁾	0.3/1 ¹⁾	1.2	60	11.61	58.2	49
DN 350															
DZR 35/2 B	0086.0060	400	50	5,900	88	4,100 ¹⁾	265 ¹⁾	2,840 ¹⁾	750 ¹⁾	1.2 ¹⁾	1.6	60	12.925	65.4	58
DZR 35/42 B	0086.0065	400	50	3,050/5,960	71/88	2,180/4,370 ¹⁾	67/240 ¹⁾	1,440/2,860 ¹⁾	140/2,860 ¹⁾	0.4/1.3 ¹⁾	1.8	60	14.2	61.8	54.5
DN 400															
EZR 40/4 B	0086.0009	230	50	4,550	75	3,258 ¹⁾	91 ¹⁾	1,420 ¹⁾	225 ¹⁾	0.9 ¹⁾	1.3	50	11.735	63	52.3
DZR 40/4 B	0086.0030	400	50	4,590	76	3,210 ¹⁾	98 ¹⁾	1,460 ¹⁾	230 ¹⁾	0.6 ¹⁾	0.7	60	13.8	65.1	54.5
DZR 40/2 B	0086.0061	400	50	9,030	93	6,515 ¹⁾	355 ¹⁾	2,930 ¹⁾	1,525 ¹⁾	2.6 ¹⁾	3.5	60	23.13	66.2	60.6
DZR 40/84 B	0086.0048	400	50	2,270/4,540	59/78	1,560/3,320 ¹⁾	25/95 ¹⁾	710/1,420 ¹⁾	45/250 ¹⁾	0.2/0.55 ¹⁾	0.7	60	14.51	58.4	48.1
DZR 40/42 B	0086.0066	400	50	4,550/9,140	76/93	3,190/6,580 ¹⁾	90/350 ¹⁾	1,480/2,920 ¹⁾	240/1,610 ¹⁾	0.8/2.7 ¹⁾	4	60	24.6	63.7	58.3
DN 450															
EZR 45/4 B	0086.0011	230	50	6,670	85	4,850 ¹⁾	112 ¹⁾	1,340 ¹⁾	445 ¹⁾	1.9 ¹⁾	2.2	60	14.81	58.3	49.7
DZR 45/6 B	0086.0032	400	50	4,460	71	3,350 ¹⁾	60 ¹⁾	985 ¹⁾	160 ¹⁾	0.55 ¹⁾	0.6	60	16	58.9	47.4
DZR 45/4 B	0086.0033	400	50	6,720	83	4,790 ¹⁾	125 ¹⁾	1,390 ¹⁾	460 ¹⁾	0.8 ¹⁾	1	60	16	64.2	55.4
DN 500															
EZR 50/6 B	0086.0013	230	50	6,030	72	4,490 ¹⁾	61 ¹⁾	950 ¹⁾	235 ¹⁾	1.1 ¹⁾	1.3	60	19.6	58.2	47.7
DZR 50/6 B	0086.0034	400	50	6,050	72	4,480 ¹⁾	60 ¹⁾	950 ¹⁾	230 ¹⁾	0.65 ¹⁾	0.7	60	19.9	58.3	47.7
DZR 50/4 B	0086.0062	400	50	8,900	81	6,560 ¹⁾	135 ¹⁾	1,410 ¹⁾	635 ¹⁾	1.1 ¹⁾	1.4	60	19.9	68.3	60.2
DZR 50/84 B	0086.0052	400	50	4,490/8,990	65/84	3,190/6,440 ¹⁾	36/150 ¹⁾	720/1,450 ¹⁾	135/710 ¹⁾	0.5/1.4 ¹⁾	1.8	60	21.87	63.4	55.7
DN 560															
DZR 56/6 B	0086.0063	400	50	8,550	73	5,970 ¹⁾	86 ¹⁾	950 ¹⁾	440 ¹⁾	1 ¹⁾	1.1	60	28.2	58.2	49.3
DZR 56/4 B	0086.0037	400	50	12,640	88	9,950 ¹⁾	170 ¹⁾	1,400 ¹⁾	1,170 ¹⁾	1.9 ¹⁾	2.4	60	35.16	66.4	60.1
DN 600															
DZR 60/6 B	0086.0064	400	50	10,060	76	7,210 ¹⁾	85 ¹⁾	930 ¹⁾	510 ¹⁾	1.1 ¹⁾	1.3	60	30.1	58.6	50.1
DZR 60/4 B	0086.0039	400	50	14,780	89	11,120 ¹⁾	160 ¹⁾	1,350 ¹⁾	1,390 ¹⁾	2.2 ¹⁾	3.2	60	36.16	62.3	56.4
DZR 60/84 B	0086.0055	400	50	7,650/15,310	70/90	5,660/11,490 ¹⁾	47/195 ¹⁾	700/1,430 ¹⁾	280/1,630 ¹⁾	1/3.1 ¹⁾	3.9	50	41	64.6	59.2

¹⁾ In opt. efficiency

BEP measured in measurement category D, total efficiency category. For further ErP data, see www.maico-fans.com.

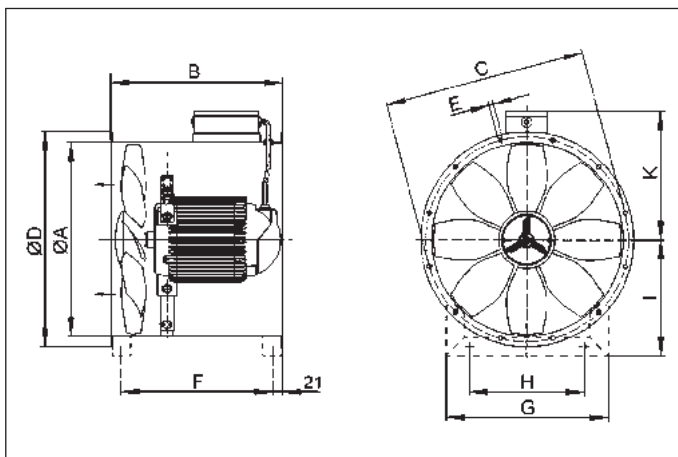
Dimensions [mm]

Number of flange holes:
6 with DN 200 and DN 250, 8 with DN 300 and DN 350 and 12 with DN 400, DN 450 and DN 500

Nominal size	A	B	C	D	E	F	G	H	I	K
DN 200	213	240	235	254	8	197	243	150	152	165
DN 250	263	300	286	304	7	255	288	150	178	194
DN 300	313	300	356	380	9	255	292	200	203	221
DN 350	363	320	395	420	9	275	319	224	226	248
DN 400	413	370	438	460	9	325	350	250	249	274
DN 450	458	310	487	510	9	255	385	280	274	297
DN 500	513	370	541	565	9	325	423	315	299	325
DN 560	570	400	629	664	14	355	485	370	345	355
DN 600	613	400	674	710	11	355	517	400	369	376

Characteristic curves for DN 200 and DN 250

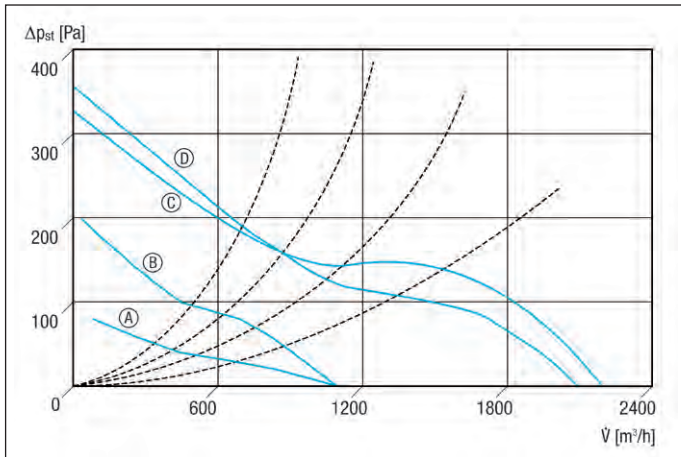

- Ⓐ EZR, DZR 25/4 D
- Ⓑ EZR, DZR 20/2 B
- Ⓒ DZR 25/2 B
- Ⓓ EZR 25/2 B

Characteristic curves for DN 300

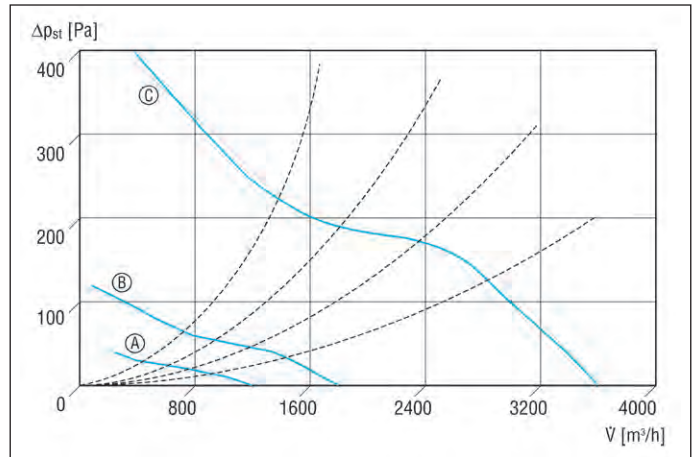

- Ⓐ EZR, DZR 30/6 B
- Ⓑ EZR, DZR 30/4 B
- Ⓒ EZR, DZR 30/2 B

Characteristic curves for DN 350

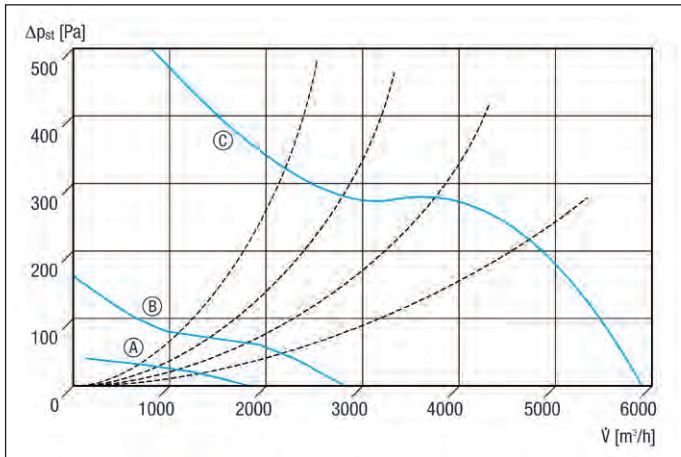

- Ⓐ EZR, DZR 35/6 B
- Ⓑ EZR, DZR 35/4 B
- Ⓒ DZR 35/2 B

Characteristic curves for DN 400

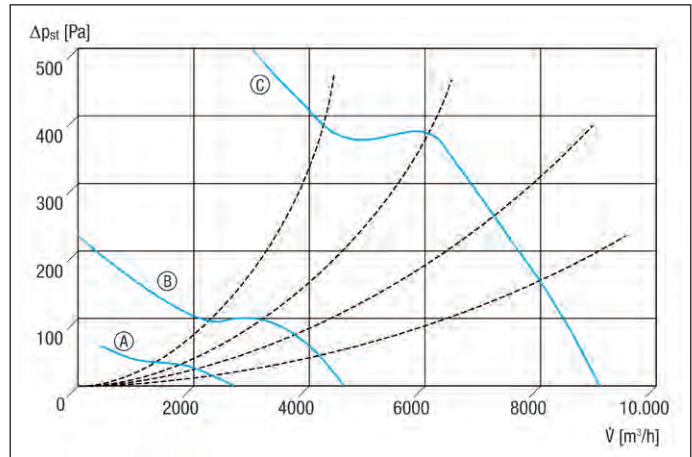

- Ⓐ EZR, DZR 40/6 B
- Ⓑ EZR, DZR 40/4 B
- Ⓒ DZR 40/2 B

Characteristic curves for DN 450 and DN 500

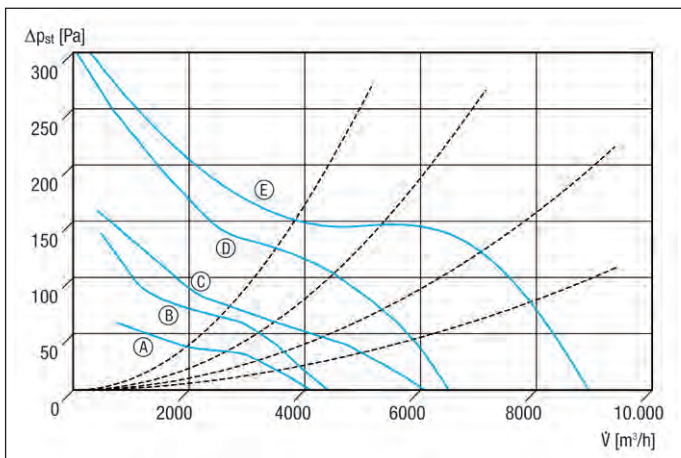

- Ⓐ EZR 50/8 B
- Ⓑ DZR 45/6 B
- Ⓒ EZR, DZR 50/6 B
- Ⓓ EZR, DZR 45/4 B
- Ⓔ DZR 50/4 B

Characteristic curves for DN 560 and DN 600

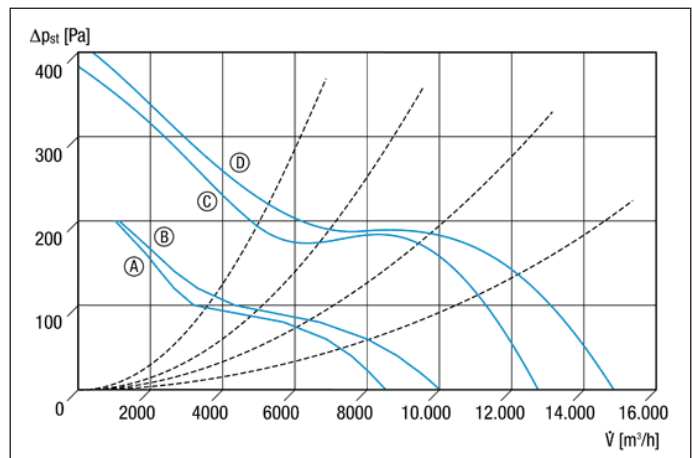

- Ⓐ DZR 56/6 B
- Ⓑ DZR 60/6 B
- Ⓒ DZR 56/4 B
- Ⓓ DZR 60/4 B

Accessories selection table

	EZR 20/2 B	DZR 20/2 B	EZR 25/4 D	EZR 25/2 B	DZR 25/4 D	DZR 25/2 B	DZR 25/84 B	EZR 30/6 B	EZR 30/4 B	see
General accessories										
Shutter	AS 20	AS 20	AS 25	AS 25	AS 25	AS 25	AS 25	AS 30	AS 30	P. 297
Shutter, manual	RS 20	RS 20	RS 25	RS 25	RS 25	RS 25	RS 25	RS 30	RS 30	P. 299
Servomotor	MS 2	MS 2	MS 2	MS 2	MS 2	MS 2	MS 2	MS 2	MS 2	P. 300 P. 223
			MS 8	MS 8	MS 8	MS 8	MS 8	MS 8	MS 8	
			MS 8 P	MS 8 P	MS 8 P	MS 8 P	MS 8 P	MS 8 P	MS 8 P	
Control shutter	–	–	JRE 25	JRE 25	JRE 25	JRE 25	JRE 25	JRE 30	JRE 30	P. 223
Protective grille, metal	SG 20	SG 20	SG 25	SG 25	SG 25	SG 25	SG 25	SG 30	SG 30	P. 221
Protective grille, synthetic material	SGK 20	SGK 20	SGK 25	SGK 25	SGK 25	SGK 25	SGK 25	SGK 30	SGK 30	P. 221
Flexible coupling	ELA 20	ELA 20	ELA 25	ELA 25	ELA 25	ELA 25	ELA 25	ELA 30	ELA 30	P. 220
Flexible cuff	EL 20	EL 20	EL 25	EL 25	EL 25	EL 25	EL 25	EL 30	EL 30	P. 219
Counter flange	GF 20	GF 20	GF 25	GF 25	GF 25	GF 25	GF 25	GF 30	GF 30	P. 222
Counter socket	GS 20	GS 20	GS 25	GS 25	GS 25	GS 25	GS 25	GS 30	GS 30	P. 222
Suction nozzle	AD 20	AD 20	AD 25	AD 25	AD 25	AD 25	AD 25	AD 30	AD 30	P. 220
Mounting foot	FU 20	FU 20	FU 25	FU 25	FU 25	FU 25	FU 25	FU 30	FU 30	P. 219
Vibration damper	GP 10	GP 10	GP 10	GP 10	GP 10	GP 10	GP 10	GP 10	GP 10	P. 219
Reversing switch	W 1	W 1	W 1	W 1	W 1	W 1	–	W 1	W 1	P. 334
	WU 1	WU 1	WU 1	WU 1	WU 1	WU 1	–	WU 1	WU 1	
Pole-changing switch	–	–	–	–	–	–	P 1	–	–	P. 335
Reversing switch, pole-changing switch	–	–	–	–	–	–	WP 1	–	–	P. 335
Speed controller	ST 1	–	ST 1	ST 2,5	–	–	–	ST 1	ST 1	P. 338
	STU 1	–	STU 1	STU 2,5	–	–	–	STU 1	STU 1	
Speed controller, reversing switch	STW 1	–	STW 1	STW 2,5	–	–	–	STW 1	STW 1	P. 339
5-step transformer	TRE 0,6-2	TR 0,4-2	TRE 0,4-2	TRE 1,6-2	TR 0,4-2	TR 0,8-2	–	TRE 0,4-2	TRE 0,6-2	P. 340
5-step transformer, control cabinet	TRE 1,6 S-2	TR 0,8 S-2	TRE 1,6 S-2	TRE 1,6 S-2	TR 0,8 S-2	TR 0,8 S-2	–	TRE 1,6 S-2	TRE 1,6 S-2	P. 341
5-step switch for TRE...S -2/ TR...S-2 5-step transformer	ESS 20	DSS 20	ESS 20	ESS 20	DSS 20	DSS 20	–	ESS 20	ESS 20	P. 341
Temperature control system	EAT 6 G/1	–	EAT 6 G/1	EAT 6 G/1	–	–	–	EAT 6 G/1	EAT 6 G/1	P. 345
	EAT 6 TG	–	EAT 6 TG	EAT 6 TG	–	–	–	EAT 6 TG	EAT 6 TG	

	EZR 30/2 B	DZR 30/6 B	DZR 30/4 B	DZR 30/2 B	DZR 30/84 B	DZR 30/42 B	EZR 35/6 B	EZR 35/4 B	see	
General accessories										
Shutter	AS 30	AS 30	AS 30	AS 30	AS 30	AS 30	AS 35	AS 35	P. 297	
Shutter, manual	RS 30	RS 30	RS 30	RS 30	RS 30	RS 30	RS 35	RS 35	P. 299	
Servomotor	MS 2	MS 2	MS 2	MS 2	MS 2	MS 2	MS 2	MS 2	P. 300 P. 223	
	MS 8	MS 8	MS 8	MS 8	MS 8	MS 8	MS 8	MS 8		
	MS 8 P	MS 8 P	MS 8 P	MS 8 P	MS 8 P	MS 8 P	MS 8 P	MS 8 P		
Control shutter	JRE 30	JRE 30	JRE 30	JRE 30	JRE 30	JRE 30	JRE 35	JRE 35	P. 223	
Protective grille, metal	SG 30	SG 30	SG 30	SG 30	SG 30	SG 30	SG 35	SG 35	P. 221	
Protective grille, synthetic material	SGK 30	SGK 30	SGK 30	SGK 30	SGK 30	SGK 30	SGK 35	SGK 35	P. 221	
Flexible coupling	ELA 30	ELA 30	ELA 30	ELA 30	ELA 30	ELA 30	ELA 35	ELA 35	P. 220	
Flexible cuff	EL 30	EL 30	EL 30	EL 30	EL 30	EL 30	EL 35	EL 35	P. 219	
Counter flange	GF 30	GF 30	GF 30	GF 30	GF 30	GF 30	GF 35	GF 35	P. 222	
Counter socket	GS 30	GS 30	GS 30	GS 30	GS 30	GS 30	GS 35	GS 35	P. 222	
Suction nozzle	AD 30	AD 30	AD 30	AD 30	AD 30	AD 30	AD 35	AD 35	P. 220	
Mounting foot	FU 30	FU 30	FU 30	FU 30	FU 30	FU 30	FU 35	FU 35	P. 219	
Vibration damper	GP 10	GP 10	GP 10	GP 10	GP 10	GP 10	GP 10	GP 10	P. 219	
Reversing switch	W 1	W 1	W 1	W 1	–	–	W 1	W 1	P. 334	
	WU 1	WU 1	WU 1	WU 1	–	–	WU 1	WU 1		
Pole-changing switch	–	–	–	–	P 1	P 1	–	–	P. 335	
Reversing switch, pole-changing switch	–	–	–	–	WP 1	WP 1	–	–	P. 335	
Speed controller	ST 5	–	–	–	–	–	ST 1	ST 1	P. 338	
	STU 5	–	–	–	–	–	STU 1	STU 1		
Speed controller, reversing switch	STW 2,5	–	–	–	–	–	STW 1	STW 1	P. 339	
5-step transformer	TRE 3,3-2	TR 0,4-2	TR 0,4-2	TR 2,5-2	–	–	TRE 0,4-2	TRE 1,6-2	P. 340	
5-step transformer, control cabinet	TRE 3,3 S-2	TR 0,8 S-2	TR 0,8 S-2	TR 2,5 S-2	–	–	TRE 1,6 S-2	TRE 1,6 S-2	P. 341	
5-step switch for TRE...S -2/ TR...S-2 5-step transformer	ESS 20	DSS 20	DSS 20	DSS 20	–	–	ESS 20	ESS 20	P. 341	
Temperature control system	EAT 6 G/1	–	–	–	–	–	EAT 6 G/1	EAT 6 G/1	P. 345	
	EAT 6 TG	–	–	–	–	–	EAT 6 TG	EAT 6 TG		

Accessories selection table

	DZR 35/6 B	DZR 35/4 B	DZR 35/2 B	DZR 35/42 B	EZR 40/6 B	EZR 40/4 B	DZR 40/6 B	DZR 40/4 B	see
General accessories									
Shutter	AS 35	AS 35	AS 35	AS 35	AS 40	AS 40	AS 40	AS 40	P. 297
Shutter, manual	RS 35	RS 35	RS 35	RS 35	RS 40	RS 40	RS 40	RS 40	P. 299
Servomotor	MS 2 MS 8 MS 8 P	MS 2 MS 8 MS 8 P	MS 2 MS 8 MS 8 P	MS 2 MS 8 MS 8 P	MS 2 MS 8 MS 8 P	MS 2 MS 8 MS 8 P	MS 2 MS 8 MS 8 P	MS 2 MS 8 MS 8 P	P. 300 P. 223
Control shutter	JRE 35	JRE 35	JRE 35	JRE 35	JRE 40	JRE 40	JRE 40	JRE 40	P. 223
Protective grille, metal	SG 35	SG 35	SG 35	SG 35	SG 40	SG 40	SG 40	SG 40	P. 221
Protective grille, synthetic material	SGK 35	SGK 35	SGK 35	SGK 35	SGK 40	SGK 40	SGK 40	SGK 40	P. 221
Flexible coupling	ELA 35	ELA 35	ELA 35	ELA 35	ELA 40	ELA 40	ELA 40	ELA 40	P. 220
Flexible cuff	EL 35	EL 35	EL 35	EL 35	EL 40	EL 40	EL 40	EL 40	P. 219
Counter flange	GF 35	GF 35	GF 35	GF 35	GF 40	GF 40	GF 40	GF 40	P. 222
Counter socket	GS 35	GS 35	GS 35	GS 35	GS 40	GS 40	GS 40	GS 40	P. 222
Suction nozzle	AD 35	AD 35	AD 35	AD 35	AD 40	AD 40	AD 40	AD 40	P. 220
Mounting foot	FU 35	FU 35	FU 35	FU 35	FU 40	FU 40	FU 40	FU 40	P. 219
Vibration damper	GP 10	GP 10	GP 10	GP 10	GP 10	GP 10	GP 10	GP 10	P. 219
Reversing switch	W 1 WU 1	W 1 WU 1	W 1 WU 1	–	W 1 WU 1	W 1 WU 1	W 1 WU 1	W 1 WU 1	P. 334
Pole-changing switch	–	–	–	P 1	–	–	–	–	P. 335
Reversing switch, pole-changing switch	–	–	–	WP 1	–	–	–	–	P. 335
Speed controller	–	–	–	–	ST 1 STU 1	ST 2,5 STU 2,5	–	–	P. 338
Speed controller, reversing switch	–	–	–	–	STW 1	STW 2,5	–	–	P. 339
5-step transformer	TR 0,4-2	TR 0,4-2	TR 2,5-2	–	TRE 0,6-2	TRE 1,6-2	TR 0,4-2	TR 0,8-2	P. 340
5-step transformer, control cabinet	TR 0,8 S-2	TR 0,8 S-2	TR 2,5 S-2	–	TRE 1,6 S-2	TRE 1,6 S-2	TR 0,8 S-2	TR 0,8 S-2	P. 341
5-step switch for TRE...S -2/ TR...S-2 5-step transformer	DSS 20	DSS 20	DSS 20	–	ESS 20	ESS 20	DSS 20	DSS 20	P. 341
Temperature control system	–	–	–	–	EAT 6 G/1 EAT 6 TG	EAT 6 G/1 EAT 6 TG	–	–	P. 345

	DZR 40/2 B	DZR 40/84 B	DZR 40/42 B	EZR 45/4 B	DZR 45/6 B	DZR 45/4 B	EZR 50/8 B	EZR 50/6 B	see
General accessories									
Shutter	AS 40	AS 40	AS 40	AS 45	AS 45	AS 45	AS 50	AS 50	P. 297
Shutter, manual	RS 40	RS 40	RS 40	RS 45	RS 45	RS 45	RS 50	RS 50	P. 299
Servomotor	MS 2 MS 8 MS 8 P	MS 2 MS 8 MS 8 P	MS 2 MS 8 MS 8 P	MS 2	MS 2	MS 2	MS 2 MS 8 MS 8 P	MS 2 MS 8 MS 8 P	P. 300 P. 223
Control shutter	JRE 40	JRE 40	JRE 40	–	–	–	JRE 50	JRE 50	P. 223
Protective grille, metal	SG 40	SG 40	SG 40	SG 45	SG 45	SG 45	SG 50	SG 50	P. 221
Protective grille, synthetic material	SGK 40	SGK 40	SGK 40	–	–	–	–	–	P. 221
Flexible coupling	ELA 40	ELA 40	ELA 40	ELA 45	ELA 45	ELA 45	ELA 50	ELA 50	P. 220
Flexible cuff	EL 40	EL 40	EL 40	EL 45	EL 45	EL 45	EL 50	EL 50	P. 219
Counter flange	GF 40	GF 40	GF 40	GF 45	GF 45	GF 45	GF 50	GF 50	P. 222
Counter socket	GS 40	GS 40	GS 40	GS 45	GS 45	GS 45	GS 50	GS 50	P. 222
Suction nozzle	AD 40	AD 40	AD 40	AD 45	AD 45	AD 45	AD 50	AD 50	P. 220
Mounting foot	FU 40	FU 40	FU 40	FU 45	FU 45	FU 45	FU 50	FU 50	P. 219
Vibration damper	GP 10	GP 10	GP 10	GP 20	GP 20	GP 20	GP 20	GP 20	P. 219
Reversing switch	W 1 WU 1	–	–	W 1 WU 1	W 1 WU 1	W 1 WU 1	W 1 WU 1 UWK 1	W 1 WU 1 UWK 1	P. 334 P. 338
Pole-changing switch	–	P 1	P 1	–	–	–	–	–	P. 335
Reversing switch, pole-changing switch	–	WP 1	WP 1	–	–	–	–	–	P. 335
Speed controller	–	–	–	ST 2,5 STU 2,5	–	–	ST 1 STU 1	ST 2,5 STU 2,5	P. 338
Speed controller, reversing switch	–	–	–	STW 2,5	–	–	STW 1	STW 2,5	P. 339
5-step transformer	–	–	–	TRE 3,3-2	TR 0,8-2	TR 2,5-2	TRE 1,6-2	TRE 1,6-2	P. 340
5-step transformer, control cabinet	–	–	–	TRE 3,3 S-2	TR 0,8 S-2	TR 2,5 S-2	TRE 1,6 S-2	TRE 1,6 S-2	P. 341
5-step switch for TRE...S -2/ TR...S-2 5-step transformer	–	–	–	ESS 20	DSS 20	DSS 20	ESS 20	ESS 20	P. 341
Temperature control system	–	–	–	EAT 6 G/1 EAT 6 TG	–	–	EAT 6 G/1 EAT 6 TG	EAT 6 G/1 EAT 6 TG	P. 345

Accessories selection table

	DZR 50/6 B	DZR 50/4 B	DZR 50/84 B	DZR 56/6 B	DZR 56/4 B	DZR 60/6 B	DZR 60/4 B	DZR 60/84 B	see
General accessories									
Shutter	AS 50	AS 50	AS 50	AS 60	AS 60	AS 60	AS 60	AS 60	P. 297
Shutter, manual	RS 50	RS 50	RS 50	RS 60	RS 60	RS 60	RS 60	RS 60	P. 299
Servomotor	MS 2 MS 8 MS 8 P	MS 2 MS 8 MS 8 P	MS 2 MS 8 MS 8 P	MS 2	MS 2	MS 2 MS 8 MS 8 P	MS 2 MS 8 MS 8 P	MS 2 MS 8 MS 8 P	P. 300 P. 223
Control shutter	JRE 50	JRE 50	JRE 50	–	–	–	–	–	P. 223
Protective grille, metal	SG 50	SG 50	SG 50	SG 56	SG 56	SG 60	SG 60	SG 60	P. 221
Flexible coupling	ELA 50	ELA 50	ELA 50	ELA 56	ELA 56	ELA 60	ELA 60	ELA 60	P. 220
Flexible cuff	EL 50	EL 50	EL 50	EL 56	EL 56	EL 60	EL 60	EL 60	P. 219
Counter flange	GF 50	GF 50	GF 50	GF 56	GF 56	GF 60	GF 60	GF 60	P. 222
Counter socket	GS 50	GS 50	GS 50	GS 56	GS 56	GS 60	GS 60	GS 60	P. 222
Suction nozzle	AD 50	AD 50	AD 50	AD 56	AD 56	AD 60	AD 60	AD 60	P. 220
Mounting foot	FU 50	FU 50	FU 50	FU 56	FU 56	FU 60	FU 60	FU 60	P. 219
Vibration damper	GP 20	GP 20	GP 20	GP 20	GP 20	GP 20	GP 20	GP 20	P. 219
Reversing switch	W 1 WU 1	W 1 WU 1	–	W 1 WU 1	W 1 WU 1	W 1 WU 1	W 1 WU 1	–	P. 334
Pole-changing switch	–	–	P 1	–	–	–	–	P 1	P. 335
Reversing switch,pole-changing switch	–	–	WP 1	–	–	–	–	WP 1	P. 335
5-step transformer	TR 0,8-2	TR 2,5-2	–	TR 2,5-2	TR 6,6-2	TR 2,5-2	TR 6,6-2	–	P. 340
5-step transformer, control cabinet	TR 0,8 S-2	TR 2,5 S-2	–	TR 2,5 S-2	TR 6,6 S-2	TR 2,5 S-2	TR 6,6 S-2	–	P. 341
5-step switch for TRE...S -2/ TR...S-2 5-step transformer	DSS 20	DSS 20	–	DSS 20	DSS 20	DSS 20	DSS 20	–	P. 341

DZR duct fan, explosion proof



Features

- Explosion protection in accordance with ATEX.
- Ex II 2G Ex e IIB+H₂ T3/T4 Gb.
- For usage temperatures of -20°C ≤ Ta ≤ +40°C.
- MAICO Ex fans fulfil the safety requirements of European Directive 2014/34/EU for units and protective systems in explosion-endangered areas.
- For zone 1 and 2.
- Duct sleeve made of galvanised sheet steel, with flanges on both sides.
- Can be fitted in any position.
- Can be switched to ventilation or air extraction.
- Reversing mode: The volumetric flow is reduced by approx. 35 % with abnormal air flow direction.

Motor

- Robust motor with ball bearings, maintenance-free.
- Motor protection class IP 54.

Electrical connection

- Separate terminal box, explosion proof, with cable screw-connections.

Safety instructions

- Speed control permitted with transformer TR.... Exception: DZ.. 35/2 B Ex e
- The temperature in the fan unit is monitored by PTC thermistors. The PTC thermistors must be connected to a triggering system (safety device according to Directive 2014/34/EU), that separates the fan permanently from the power if the temperature gets too hot.
- The MAICO PTC thermistor triggering device MVS 6 or TMS is recommended as the triggering system.
- The fan may be operated only if the protection against accidental contact with the impeller is guaranteed to be in accordance with DIN EN ISO 13857 for fans with free inlet and outlet, e.g. with an SG protective grille.

Required safety technology

- A PTC thermistor triggering device is needed to fuse the DZR-Ex units.
- Maico provides the MVS 6 PTC thermistor triggering device and TMS for this purpose.
- MVS 6 PTC thermistor triggering device
 - Independent complete system.
 - For monitoring the maximum motor temperature.
 - Type-examination tested according to Directive 2014/34/EU (ATEX).
 - Installation exclusively in non-explosive areas.



- TMS PTC thermistor triggering device
 - For monitoring the maximum motor temperature.
 - Suitable for installation in control cabinets
 - Type-examination tested according to Directive 2014/34/EU (ATEX).
 - Installation exclusively in non-explosive areas.



Special versions

- Special voltages are available on request, at an extra cost.
- Information on operation at temperatures occasionally below -20°C available upon request.
- Feasibility must be checked in each case.

Technical data

Article	Art. No.	U _{nom}	f _{nom}	Air flow volume	Rotating speed	P _{nom}	I _{nom}	Sound power level L _{WAS}	Degree of protection	Temperature class	Insulation class	Weight
		V	Hz	m ³ /h	1/min	W	A	dB(A)	IP			kg
DZR 20/2 B Ex e	0086.0700	400	50	1,050	2,950	65	0.23	80	54	T4	F	7.2
DZR 25/4 B Ex e	0086.0701	400	50	980	1,475	38	0.19	65	54	T4	F	8.5
DZR 25/2 B Ex e	0086.0702	400	50	1,950	2,880	130	0.28	81	54	T4	F	8.6
DZR 30/6 B Ex e	0086.0703	400	50	1,130	985	25	0.12	58	54	T4	F	11.8
DZR 30/4 B Ex e	0086.0704	400	50	1,760	1,475	95	0.48	66	54	T3	F	9.5
DZR 30/2 B Ex e	0086.0705	400	50	3,410	2,910	240	0.46	85	54	T3	F	12.3
DZR 35/6 B Ex e	0086.0706	400	50	1,700	970	35	0.13	58	54	T4	F	13
DZR 35/4 B Ex e	0086.0707	400	50	2,650	1,455	125	0.49	72	54	T3	F	10.6
DZR 35/2 B Ex e	0086.0708	400	50	5,230	2,910	530	1.25	89	54	T3	F	13.2
DZR 40/6 B Ex e	0086.0709	400	50	2,770	985	95	0.54	66	54	T4	F	14.4
DZR 40/4 B Ex e	0086.0710	400	50	4,200	1,465	170	0.55	76	54	T4	F	14.6
DZR 45/6 B Ex e	0086.0711	400	50	4,160	965	150	0.56	69	54	T4	F	15
DZR 45/4 B Ex e	0086.0712	400	50	6,200	1,420	350	0.72	78	54	T4	F	15
DZR 50/6 B Ex e	0086.0713	400	50	5,520	955	175	0.57	71	54	T4	F	16.7
DZR 50/4 B Ex e	0086.0714	400	50	8,190	1,435	445	0.86	82	54	T3	F	22.7
DZR 60/6 B Ex e	0086.0715	400	50	9,370	960	295	0.66	77	54	T3	F	30.1

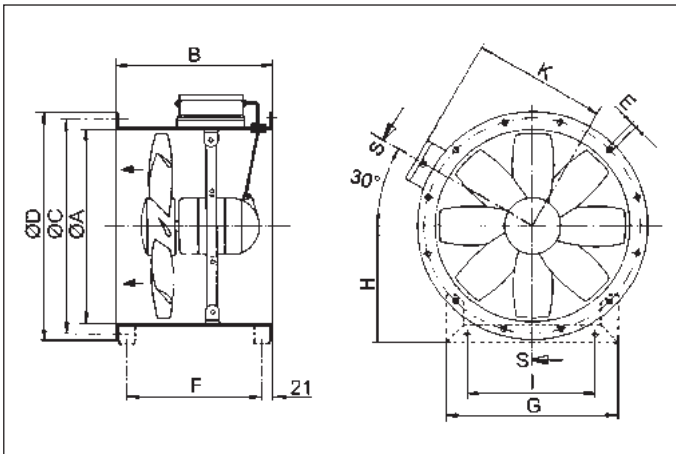

Dimensions [mm]

Nominal size	A	B	C	D	E	F	G	H	I	K
DZR-Ex - DN 200	213	240	235	254	7	193	243	152	150	165
DZR-Ex - DN 250	263	300	286	304	7	255	288	178	150	194
DZR-Ex - DN 300	313	300	356	380	9	255	292	203	200	221
DZR-Ex - DN 350	363	320	395	420	9	275	319	226	224	248
DZR-Ex - DN 400	413	370	438	460	9	325	350	249	250	274
DZR-Ex - DN 450	458	310	487	510	9	255	385	274	280	297
DZR-Ex - DN 500	513	370	541	565	9	325	423	299	315	325
DZR-Ex - DN 600	613	400	674	710	11	355	517	369	400	376

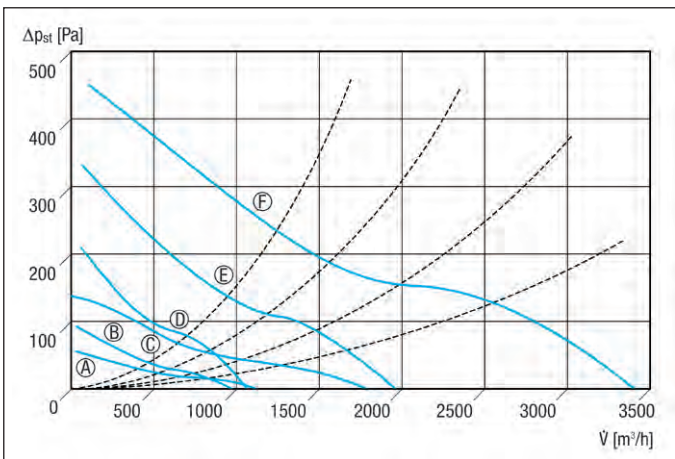
Characteristic curves for DN 200 to DN 300

- Ⓐ DZR 30/6 B Ex
- Ⓑ DZR 25/4 B Ex
- Ⓒ DZR 30/4 B Ex
- Ⓓ DZR 20/2 B Ex
- Ⓔ DZR 25/2 B Ex
- Ⓕ DZR 30/2 B Ex

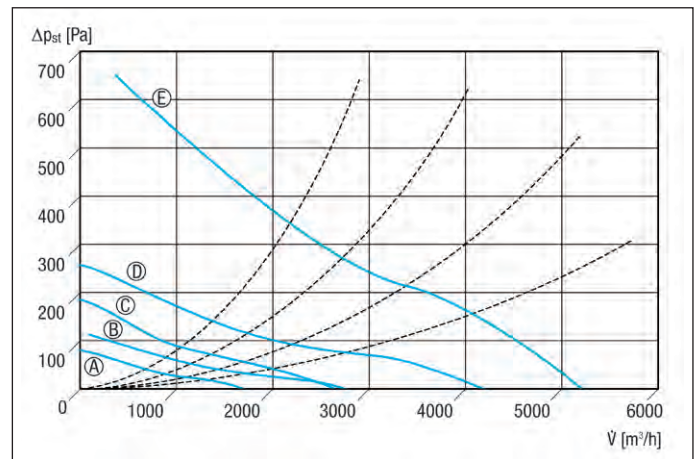
Characteristic curves for DN 350 to DN 400

- Ⓐ DZR 35/6 B Ex
- Ⓑ DZR 40/6 B Ex
- Ⓒ DZR 35/4 B Ex
- Ⓓ DZR 40/4 B Ex
- Ⓔ DZR 35/2 B Ex

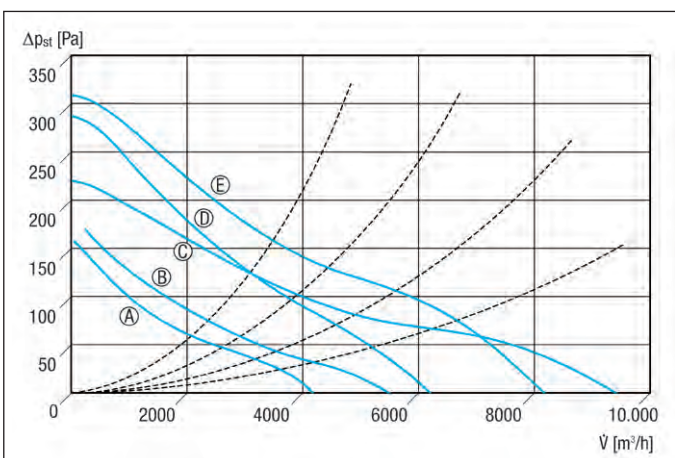
Characteristic curves for DN 450 to DN 600

- Ⓐ DZR 45/6 B Ex
- Ⓑ DZR 50/6 B Ex
- Ⓒ DZR 60/6 B Ex
- Ⓓ DZR 45/4 B Ex
- Ⓔ DZR 50/4 B Ex

Accessories selection table

	DZR 20/2 B Ex e	DZR 25/4 B Ex e	DZR 25/2 B Ex e	DZR 30/6 B Ex e	DZR 30/4 B Ex e	DZR 30/2 B Ex e	DZR 35/6 B Ex e	DZR 35/4 B Ex e	see
Specific accessories									
Flexible coupling	ELA 20 Ex	ELA 25 Ex	ELA 25 Ex	ELA 30 Ex	ELA 30 Ex	ELA 30 Ex	ELA 35 Ex	ELA 35 Ex	P. 220
Flexible cuff	EL 20 Ex	EL 25 Ex	EL 25 Ex	EL 30 Ex	EL 30 Ex	EL 30 Ex	EL 35 Ex	EL 35 Ex	P. 219
PTC thermistor triggering device	MVS 6	MVS 6	MVS 6	MVS 6	MVS 6	MVS 6	MVS 6	MVS 6	P. 336
Machine protection relay thermistor	TMS	TMS	TMS	TMS	TMS	TMS	TMS	TMS	P. 336
General accessories									
Shutter	AS 20	AS 25	AS 25	AS 30	AS 30	AS 30	AS 35	AS 35	P. 297
Protective grille, metal	SG 20	SG 25	SG 25	SG 30	SG 30	SG 30	SG 35	SG 35	P. 221
Counter flange	GF 20	GF 25	GF 25	GF 30	GF 30	GF 30	GF 35	GF 35	P. 222
Counter socket	GS 20	GS 25	GS 25	GS 30	GS 30	GS 30	GS 35	GS 35	P. 222
Suction nozzle	AD 20	AD 25	AD 25	AD 30	AD 30	AD 30	AD 35	AD 35	P. 220
Mounting foot	FU 20	FU 25	FU 25	FU 30	FU 30	FU 30	FU 35	FU 35	P. 219
Vibration damper	GP 10	GP 10	GP 10	GP 10	GP 10	GP 10	GP 10	GP 10	P. 219
Reversing switch	W 1 WU 1	W 1 WU 1	W 1 WU 1	W 1 WU 1	W 1 WU 1	W 1 WU 1	W 1 WU 1	W 1 WU 1	P. 334
5-step transformer	TR 0,4-2	TR 0,4-2	TR 0,4-2	TR 0,8-2	TR 0,8-2	TR 2,5-2	TR 0,8-2	TR 0,8-2	P. 340
5-step transformer, control cabinet	TR 0,8 S-2	TR 0,8 S-2	TR 0,8 S-2	TR 0,8 S-2	TR 0,8 S-2	TR 2,5 S-2	TR 0,8 S-2	TR 0,8 S-2	P. 341
5-step switch for TRE...S -2/ TR...S-2 5-step transformer	DSS 20	DSS 20	DSS 20	DSS 20	DSS 20	DSS 20	DSS 20	DSS 20	P. 341

	DZR 35/2 B Ex e	DZR 40/6 B Ex e	DZR 40/4 B Ex e	DZR 45/6 B Ex e	DZR 45/4 B Ex e	DZR 50/6 B Ex e	DZR 50/4 B Ex e	DZR 60/6 B Ex e	see
Specific accessories									
Flexible coupling	ELA 35 Ex	ELA 40 Ex	ELA 40 Ex	ELA 45 Ex	ELA 45 Ex	ELA 50 Ex	ELA 50 Ex	ELA 60 Ex	P. 220
Flexible cuff	EL 35 Ex	EL 40 Ex	EL 40 Ex	EL 45 Ex	EL 45 Ex	EL 50 Ex	EL 50 Ex	EL 60 Ex	P. 219
PTC thermistor triggering device	MVS 6	MVS 6	MVS 6	MVS 6	MVS 6	MVS 6	MVS 6	MVS 6	P. 336
Machine protection relay thermistor	TMS	TMS	TMS	TMS	TMS	TMS	TMS	TMS	P. 336
General accessories									
Shutter	AS 35	AS 40	AS 40	AS 45	AS 45	AS 50	AS 50	AS 60	P. 297
Protective grille, metal	SG 35	SG 40	SG 40	SG 45	SG 45	SG 50	SG 50	SG 60	P. 221
Counter flange	GF 35	GF 40	GF 40	GF 45	GF 45	GF 50	GF 50	GF 60	P. 222
Counter socket	GS 35	GS 40	GS 40	GS 45	GS 45	GS 50	GS 50	GS 60	P. 222
Suction nozzle	AD 35	AD 40	AD 40	AD 45	AD 45	AD 50	AD 50	AD 60	P. 220
Mounting foot	FU 35	FU 40	FU 40	FU 45	FU 45	FU 50	FU 50	FU 60	P. 219
Vibration damper	GP 10	GP 10	GP 10	GP 20	GP 20	GP 20	GP 20	GP 20	P. 219
Reversing switch	W 1 WU 1	W 1 WU 1	W 1 WU 1	W 1 WU 1	W 1 WU 1	W 1 WU 1	W 1 WU 1	W 1 WU 1	P. 334
5-step transformer	-	TR 0,8-2	TR 0,8-2	TR 0,8-2	TR 0,8-2	TR 0,8-2	TR 2,5-2	TR 0,8-2	P. 340
5-step transformer, control cabinet	-	TR 0,8 S-2	TR 0,8 S-2	TR 0,8 S-2	TR 0,8 S-2	TR 0,8 S-2	TR 2,5 S-2	TR 0,8 S-2	P. 341
5-step switch for TRE...S -2/ TR...S-2 5-step transformer	-	DSS 20	DSS 20	DSS 20	DSS 20	DSS 20	DSS 20	DSS 20	P. 341

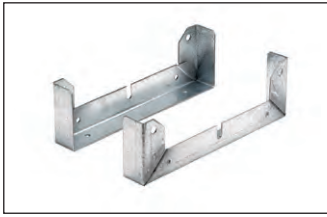
**Mounting feet
FU**

- Mounting feet for the assembly of EZR/DZR fans on walls, ceilings or brackets.

Dimensions [mm]

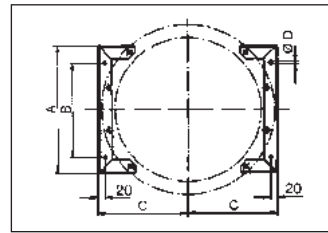
Common features

Material	Sheet steel, galvanised
Packing unit	2 pieces

Article	Art. No.	Nominal size mm
FU 20	0036.0069	200
FU 25	0036.0070	250
FU 30	0036.0071	300
FU 35	0036.0072	350
FU 40	0036.0073	400
FU 45	0036.0074	450
FU 50	0036.0075	500
FU 56	0036.0076	560
FU 60	0036.0077	600

Article	A mm	B mm	C mm	D mm
FU 20	243	150	152	7
FU 25	288	150	178	7
FU 30	292	200	203	7
FU 35	319	224	226	7
FU 40	350	250	249	7
FU 45	385	280	274	7
FU 50	423	315	299	11
FU 56	485	370	345	11
FU 60	517	400	345	11

**Vibration dampers
GP**

- 4 vibration dampers for the vibration damped mounting of fans.

Dimensions [mm]

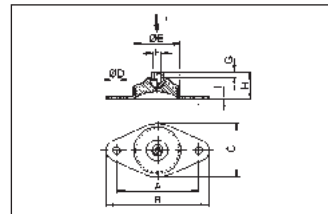

ⓐ Only for this load direction.

Article	Art. No.
GP 10	0092.0151
GP 20	0092.0152

Article	A	B	C	D	E	F	G	H	I
	mm	mm	mm	mm	mm	mm	mm	mm	mm
GP 10	45	60	35	6	30	M6	5	18	1
GP 20	70	90	50	9	45	M10	8	29	1.5

Common features

Material	Sheet steel, galvanised
Packing unit	4 pieces

**Flexible cuffs
EL/EL Ex**

- Flexible cuffs for sound and vibration damped assembly of duct fans.
- With 2 tightening straps.
- EL ...: Made of plastic.
- EL .. Ex: Made of antistatic material, for use in areas subject to explosion hazards.

Dimensions [mm]

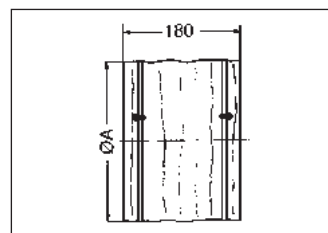
Common features

Max. ambient temperature	80 °C
--------------------------	-------

Article	Art. No.	Nominal size mm
EL 20	0092.0154	200
EL 25	0092.0088	250
EL 30	0092.0089	300
EL 35	0092.0090	350
EL 40	0092.0091	400
EL 45	0092.0155	450
EL 50	0092.0092	500
EL 56	0092.0150	560
EL 60	0092.0093	600
EL 20 Ex	0092.0231	200
EL 25 Ex	0092.0232	250
EL 30 Ex	0092.0233	300
EL 35 Ex	0092.0234	350
EL 40 Ex	0092.0235	400
EL 45 Ex	0092.0236	450
EL 50 Ex	0092.0237	500
EL 60 Ex	0092.0238	600

Article	A mm
EL 20	213
EL 25	263
EL 30	313
EL 35	363
EL 40	413
EL 45	458
EL 50	513
EL 56	570
EL 60	613
EL 20 Ex	213
EL 25 Ex	263
EL 30 Ex	313
EL 35 Ex	363
EL 40 Ex	413
EL 45 Ex	458
EL 50 Ex	513
EL 60 Ex	613

**Flexible couplings
ELA/ELA Ex**



- Flexible couplings for the sound and vibration damped connection of ventilation ducts.
- With flanges fitted on the fan side.
- With push-in couplings on the duct side.
- ELA ...: Made of plastic.
- ELA .. Ex: Made of antistatic material, for use in areas subject to explosion hazards.

Dimensions [mm]

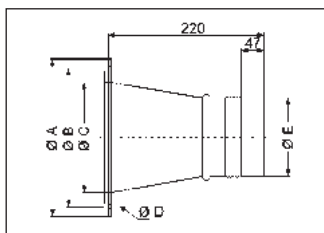

Common features

Flange material Steel, galvanised

Article	Art. No.	Nominal size mm
ELA 18	0092.0283	180
ELA 20	0092.0265	200
ELA 22	0092.0282	224
ELA 25	0092.0266	250
ELA 30	0092.0267	300
ELA 31	0092.0284	315
ELA 35	0092.0268	355
ELA 40	0092.0269	400
ELA 45	0092.0270	450
ELA 50	0092.0271	500
ELA 56	0092.0272	560
ELA 60	0092.0273	600
ELA 20 Ex	0092.0274	200
ELA 25 Ex	0092.0275	250
ELA 30 Ex	0092.0276	300
ELA 31 Ex	0092.0285	315
ELA 35 Ex	0092.0277	350
ELA 40 Ex	0092.0278	400
ELA 45 Ex	0092.0279	450
ELA 50 Ex	0092.0280	500
ELA 60 Ex	0092.0281	600

Article	A mm	B mm	C mm	D mm	E mm
ELA 18	232	213	190	7	178
ELA 20	254	235	212	7	198
ELA 22	280	259	238	7	222
ELA 25	304	286	262	7	247
ELA 30	380	356	312	9.5	297
ELA 31	380	356	312	9.5	312
ELA 35	420	395	362	9.5	352
ELA 40	460	438	412	9.5	397
ELA 45	510	487	457	9.5	447
ELA 50	565	541	512	9.5	497
ELA 56	664	629	569	14	557
ELA 60	710	674	612	14	597
ELA 20 Ex	254	235	212	7	198
ELA 25 Ex	304	286	262	7	247
ELA 30 Ex	380	356	312	9.5	297
ELA 31 Ex	380	356	312	9.5	312
ELA 35 Ex	420	395	362	9.5	347
ELA 40 Ex	460	438	412	9.5	397
ELA 45 Ex	510	487	457	9.5	447
ELA 50 Ex	565	541	512	9.5	497
ELA 60 Ex	710	674	612	14	597

**Suction nozzles
AD**



- Suction nozzle for turbulence-reduced air intake.

Dimensions [mm]

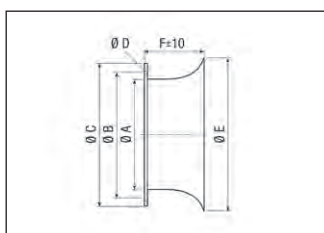

Common features

Material Sheet steel, galvanised
Air direction Ventilation and air extraction

Article	Art. No.	Nominal size mm
AD 20	0180.0628	200
AD 25	0180.0620	250
AD 30	0180.0621	300
AD 35	0180.0622	350
AD 40	0180.0623	400
AD 45	0180.0624	450
AD 50	0180.0625	500
AD 56	0180.0626	560
AD 60	0180.0627	600

Article	A mm	B mm	C mm	D mm	E mm	F mm
AD 20	213	235	254	8	265	110
AD 25	263	286	314	7.5	335	110
AD 30	313	356	380	10	385	100
AD 35	363	395	420	10	435	100
AD 40	413	438	460	10	485	100
AD 45	458	487	510	10	535	100
AD 50	513	541	565	10	585	100
AD 56	570	629	664	14	657	90
AD 60	613	676	710	14	700	90

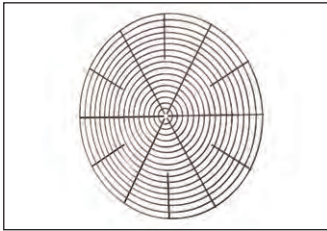
**Protective grilles, metal
SG**

- Protective grille for fans in accordance with DIN EN ISO 13857.
- Suitable for fans with duct connections.
- Can be fitted on the inlet or pressure side.
- Made of antistatic material, for use in areas subject to explosion hazards.

Article	Art. No.	Nominal size mm
SG 20	0150.0114	200
SG 25	0150.0115	250
SG 30	0150.0116	300
SG 35	0150.0117	350
SG 40	0150.0118	400
SG 45	0150.0119	450
SG 50	0150.0120	500
SG 56	0150.0121	560
SG 60	0150.0122	600

Dimensions [mm]

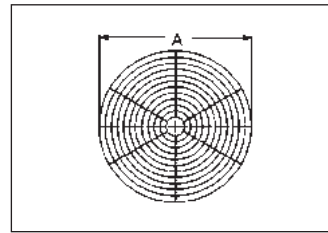

Article	A mm
SG 20	249
SG 25	297
SG 30	369
SG 35	410
SG 40	455
SG 45	500
SG 50	558
SG 56	646
SG 60	698

Common features

Material	Wire, chromated
Air direction	Ventilation and air extraction

Pressure losses

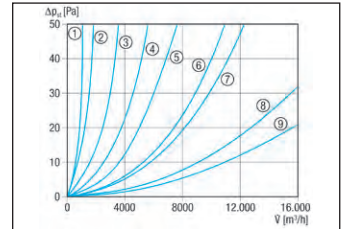

- ① SG 20
- ② SG 25
- ③ SG 30
- ④ SG 35
- ⑤ SG 40
- ⑥ SG 45
- ⑦ SG 50
- ⑧ SG 56
- ⑨ SG 60

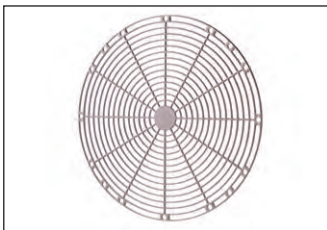
**Protective grilles,
synthetic material
SGK**

- Protective grille for fans in accordance with DIN EN ISO 13857.
- Suitable for EZQ / DZQ, EZR / DZR and EZD / DZD.
- Can be fitted on the inlet or pressure side.
- Do not use in areas subject to explosions.

Article	Art. No.	Nominal size mm
SGK 20	0059.0161	200
SGK 25	0059.0162	250
SGK 30	0059.0163	300
SGK 35	0059.0164	350
SGK 40	0059.0165	400

Dimensions [mm]

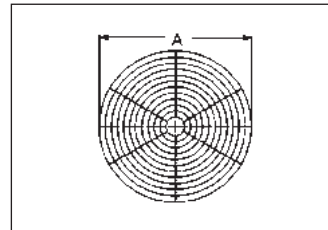

Article	A mm
SGK 20	249
SGK 25	297
SGK 30	369
SGK 35	410
SGK 40	455

Common features

Material	Synthetic material
Max. ambient temperature	65 °C
Air direction	Ventilation and air extraction

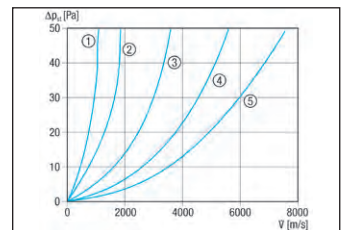

- ① SGK 20
- ② SGK 25
- ③ SGK 30
- ④ SGK 35
- ⑤ SGK 40

**Counter flanges
GF**

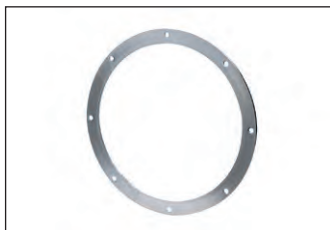

- Counter flange for the assembly of fans to ventilation ducts.

Dimensions [mm]

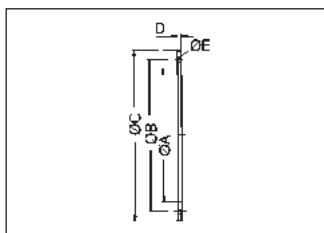

Common features

Material Steel, galvanised

Article	Art. No.	Nominal size mm
GF 20	0056.0002	200
GF 25	0056.0003	250
GF 30	0056.0004	300
GF 35	0056.0005	350
GF 40	0056.0006	400
GF 45	0056.0007	450
GF 50	0056.0008	500
GF 56	0056.0010	560
GF 60	0056.0009	600

Article	A mm	B mm	C mm	D mm	E mm
GF 20	213	235	254	5	7
GF 25	263	286	304	5	7
GF 30	313	356	380	6	9.5
GF 35	363	395	420	6	9.5
GF 40	413	438	460	6	9.5
GF 45	458	487	510	6	9.5
GF 50	513	514	565	6	9.5
GF 56	570	629	664	6	9.5
GF 60	613	674	710	6	9.5

**Counter sockets
GS**



- Counter socket for fitting flexible cuffs on ventilation ducts.
- Suited to assembly of folded spiral-seams duct in combination with EL / EL Ex flexible cuffs only.

Dimensions [mm]

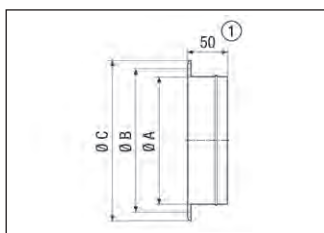

Common features

Material Sheet steel, galvanised

Article	Art. No.	Suitable for nominal size cuffs mm
GS 20	0055.0168	200
GS 25	0055.0169	250
GS 30	0055.0170	300
GS 35	0055.0171	350
GS 40	0055.0172	400
GS 45	0055.0173	450
GS 50	0055.0174	500
GS 56	0055.0176	560
GS 60	0055.0175	600

① GS 56: 55 mm

Article	A mm	B mm	C mm	D mm
GS 20	210	235	254	8
GS 25	263	286	304	8
GS 30	313	356	380	10
GS 35	363	395	420	10
GS 40	413	438	460	10
GS 45	458	487	512	10
GS 50	513	541	565	10
GS 56	570	629	664	14
GS 60	613	674	710	14

**Control shutters
JRE**

- Blind control shutters for automatic activation.
- Must be combined with additional MS 8 or MS 8 P servomotors (servomotor is not included in the scope of delivery).
- Do not use in areas subject to explosions.

Installation instructions

- Ensure access to the servomotor.

Dimensions [mm]

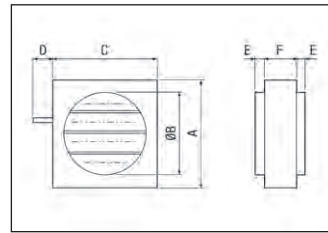

Common features

Material	Sheet steel, galvanised
Installation site	Duct
Air direction	Ventilation and air extraction
Type of shutter	electrical

Article	Art. No.	Nominal size mm
JRE 25	0151.0390	250
JRE 30	0151.0391	300
JRE 35	0151.0392	350
JRE 40	0151.0393	400
JRE 50	0151.0394	500
JRE 60	0151.0395	600

Article	A	B	C	D	E	F
	mm	mm	mm	mm	mm	mm
JRE 25	308	250	305	58	41	69
JRE 30	358	300	355	58	41	69
JRE 35	408	350	405	58	41	69
JRE 40	458	400	455	58	55	69
JRE 50	558	500	555	58	55	69
JRE 60	658	600	655	58	55	69

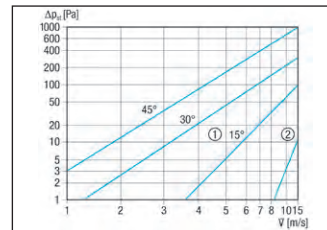
Pressure losses



- ① Opening angle of lamella
- ② open

**Servo motors
MS 8**

Article	Art. No.
MS 8	0157.0760
MS 8 P	0157.0761

- Servomotors for opening and closing the RKP duct shutter and JRE blind control shutter.
- With limiting strap for torsion safety.
- Can be combined with drive axis up to 20 mm diameter or 16 mm square.
- Maximum turning angle: 90°.
- Turning angle limit adjustable in 5° steps.
- With two-point control for "Open" and "Closed" settings.
- Drive axis can be rotated to the right or left.
- MS 8 P: With 2 additional auxiliary switches.
- Not suitable for use in areas subject to explosion hazards.

Installation instruction

- With pushbutton for release of the gear, e.g. for manual setting of the shutter.
- If PG 11 screws are used: IP 54 degree of protection.
- Note: US 16 T universal contactor or customer-provided relay required for speed control with phase angles.
- 4-core mains cable is needed.

Common features

U_{nom}	230 V
f_{nom}	50 Hz/60 Hz
Degree of protection	IP 44
Maximum load (inductive load)	2 A
Maximum load (ohmic load)	10 A
Housing material	Synthetic material, weather and UV resistant
Colour	Blue
Width	100 mm
Height	180 mm
Depth	65 mm

Centrifugal, semi-centrifugal and diagonal duct fans

Example illustration of a ventilation installation

- Duct ventilation systems from MAICO are our response to your requirements. After all, these systems are suited to numerous applications:
 - Production areas
 - Machine extraction units
 - Commercial kitchens
- MAICO offers a wide range of ventilation systems, particularly for use in areas subject to explosion hazards, which meet the most current standards.
- As a rule, duct ventilation systems are used wherever high levels of pressure are needed.
- The air volume of the various systems extends to 20,200 m³/h for ventilating and extracting air. The associated fans are available in nominal sizes of between 100 mm to 710 mm in diameter.
- It doesn't matter which MAICO duct ventilation system you work with: Their benefit lies in the modular system. Because all the components fit together regardless of the nominal sizes or product groups involved.
- MAICO also offers an extensive range of accessories:
 - Sound absorber
 - Electric-air or water air heater
 - Air filter
 - Shutters and grilles for inside and outside

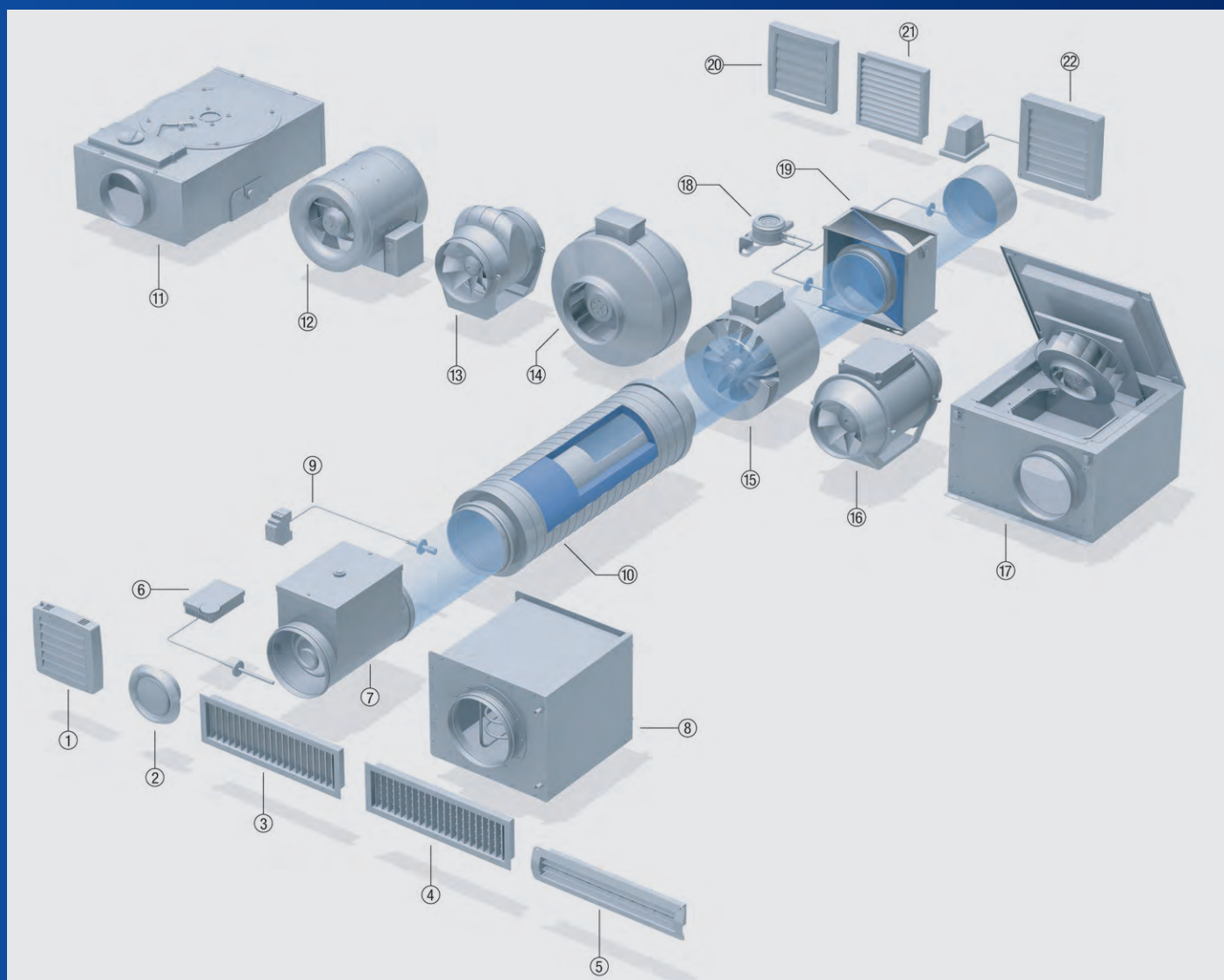

- | | |
|---------------------------------|--|
| ① Electrical internal shutter | ⑭ ERM Semi-centrifugal duct fan |
| ② Disk valve | ⑮ ERR Centrifugal duct fan |
| ③ Exhaust air grille | ⑯ HDR / HDR EC diagonal duct fan |
| ④ Supply air grille | ⑰ ESR-2 EC sound-insulated ventilation box with swivellable fan unit |
| ⑤ Supply and extract air grille | ⑱ Air filter |
| ⑥ Temperature controller | ⑲ Differential pressure monitor |
| ⑦ Electric air heater | ⑳ Airstream-operated shutter |
| ⑧ Water air heater | ㉑ External grille |
| ⑨ Air flow monitor | ㉒ Electrical shutter |
| ⑩ Tubular sound absorber | |
| ⑪ EFR centrifugal flat box | |
| ⑫ EDR Diagonal fan | |
| ⑬ ERK Diagonal fan | |

Semi-centrifugal duct fans

ERM up to 290 m³/h

ERM, explosion proof up to 870 m³/h

Semi-centrifugal duct fan accessories



Page 226

Page 228

Page 230

Centrifugal duct fans

ERR standard solution, up to 1,370 m³/h



Page 232

AWV external wall fan

External installation solves problems of space and noise, up to 740 m³/h



Page 234

EFR centrifugal flat box

Compact measurements for installation in very tight spaces, up to 255 m³/h



Page 236

Sound-insulated ventilation boxes

ESR -2 EC EC technology, up to 2,050 m³/h

NEW!



Page 238

Diagonal fans

HDR/HDR EC highly efficient and powerful, up to 684 m³/h

ERK with and without follow-up relay, up to 910 m³/h

EDR with stator for maximum efficiency, up to 20,240 m³/h

NEW!



Page 240

Page 242

Page 244

EKR -2 sound-insulated ventilation box

Motor location outside the air flow, up to 7,750 m³/h

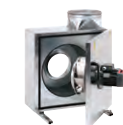

Page 246

Accessories

Mounting feet, flexible cuffs, flexible couplings, shutters, protective grilles, sound insulation, air filters, air heaters, etc.



Page 248

ERM semi-centrifugal duct fan



Features

- Reduced space requirement due to compact dimensions.
- IP 54 degree of protection for horizontal installation positions or when the airstream direction is downwards.
- Inlet and outlet side connection couplings for direct installation in ventilation ducts.
- Semi-centrifugal impeller, favourable flow technology.
- Inflow direction equals outflow direction. Thus resulting in simple installation.
- Pearl white, similar to RAL 1013.

Mounting instructions

- Can be fitted in any position.
- Use ELM flexible cuffs to prevent transfer of vibrations onto the duct system.

Motor

- ERM 15: Shaded-pole motor
- ERM 18: Capacitor motor
- Speed controllable.
- Operating capacitor in the terminal box is ready to be connected.
- Thermal overload protection as a standard feature.
- Potential-free terminal connections, which must be connected to e.g. an MVE 10 protective motor switch or the control circuit of a contactor.
- Robust motor with ball bearings, maintenance-free.

Electrical connection

- Externally fitted terminal box with cable guide bushes.

Safety instructions

- The fan may be operated only if the protection against accidental contact with the impeller is guaranteed to be in accordance with DIN EN ISO 13857 for fans with free inlet or free outlet. To do this, fit a SGM protective grille.

Special versions

- The following special versions are available on request, at an extra cost:
 - Special voltages and frequencies.
 - PTC thermistor on terminals.
- Information on operation at temperatures occasionally below -20°C available upon request.
- Feasibility must be checked in each case.

Technical data

Article	Art. No.	U _{nom} V	f _{nom} Hz	Air flow volume m ³ /h	Rotating speed 1/min	P _{nom} W	I _{nom} A	I _{max} A	T _{max} at I _{max} °C	Sound power level L _{WA2} dB(A)	Insulation class	Weight kg
ERM 15	0080.0203	230	50	140 ¹⁾	2,600	38	0.26	0.26	55	49	B	1.8
ERM 18	0080.0251	230	50	290 ¹⁾	2,760	50	0.25	0.27	55	57	B	2.2

¹⁾ Measured with 1 m duct on the inlet and outlet side

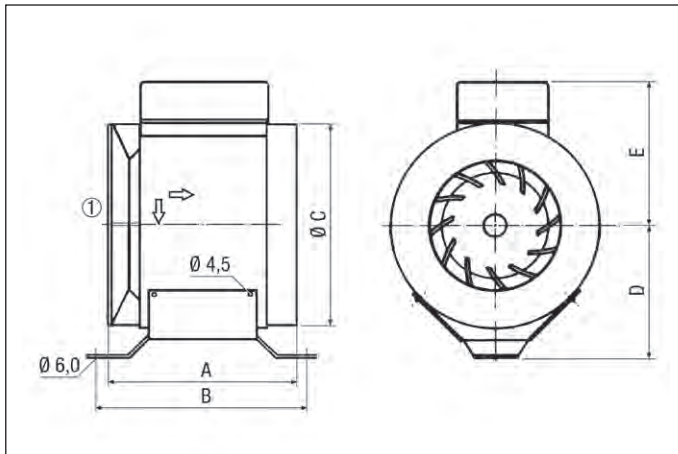
Dimensions [mm]

Article	A	B	C	D	E
ERM 15	151	187	148	93	112
ERM 18	161	187	177	120	125

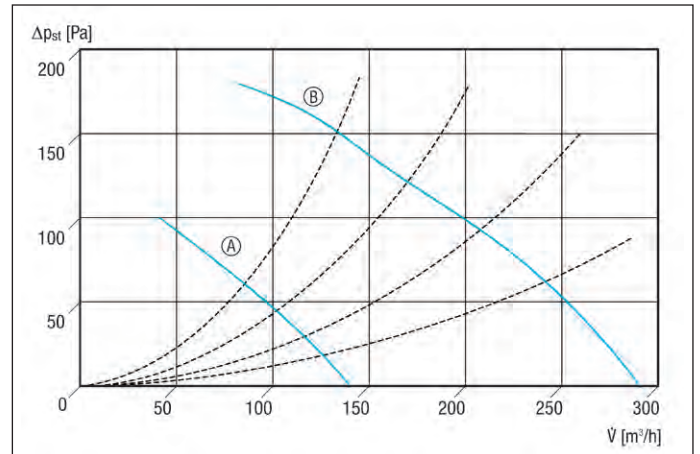
Characteristic curves for ERM 15 and ERM 18

Ⓐ ERM 15
Ⓑ ERM 18

Accessories selection table

	ERM 15	ERM 18	see
Specific accessories			
Flexible cuff	ELM 15	ELM 18	P. 230
Mounting foot	FUM 15/18	FUM 15/18	P. 230
General accessories			
Shutter	AP 150	AP 150	P. 296
Automatic backflow preventer	AVM 15	AVM 18	P. 249
Protective grille	SGM 15	SGM 18	P. 231
Reducer	REM 15/10	REM 18/14 REM 18/12 REM 18/10	P. 231
Tubular sound absorber	RSR 15 RSR 15/50	–	P. 250
Water air heater	WRH 10-1	WRH 12-1	P. 255
Air filter	TFE 15-4 TFE 15-5 TFE 15-7	–	P. 250, P. 251
Speed controller	–	ST 1 STU 1	P. 338
Speed controller, distribution board	–	STS 2,5	P. 339
5-step transformer	TRE 0,4-2	TRE 0,4-2	P. 340
5-step transformer, control cabinet	TRE 1,6 S-2	TRE 1,6 S-2	P. 341
5-step switch for TRE...S -2/ TR...S-2 5-step transformer	ESS 20	ESS 20	P. 341

ERM semi-centrifugal duct fan, explosion proof



Features

- Explosion protection in accordance with ATEX.
- Ex II 2G Ex e IIB+H₂ T3/T4 Gb.
- For usage temperatures of -20°C ≤ Ta ≤ +50°C.
- MAICO Ex fans fulfil the safety requirements of European Directive 2014/34/EU for units and protective systems in explosion-endangered areas.
- For zone 1 and 2.
- Housing and impeller are made from high quality synthetic material, antistatic.
- Semi-centrifugal impeller, favourable flow technology.
- Inflow direction equals outflow direction. Thus resulting in simple installation.
- Can be fitted in any position.

Mounting instructions

- Inlet and outlet side connection couplings for direct installation in ventilation ducts.
- Reducers for connecting to different duct diameters (intake or exhaust sockets); see accessories.
- Use ELM-Ex flexible cuffs to prevent transfer of vibrations onto the duct system.
- ERM 22 Ex e: 2 reducers to DN 200 included in scope of delivery.

Motor

- Robust motor with ball bearings, maintenance-free.
- Capacitor motor with operating capacitor fitted ready for use on fan.

Electrical connection

- Terminal box fitted to fan housing, explosion proof.

Safety instructions

- No speed control allowed.
- Fan may only be operated using the rated voltage shown on the rating plate.
- The fan may be operated only if the protection against accidental contact with the impeller is guaranteed to be in accordance with DIN EN ISO 13857 for fans with free inlet or outlet. To do this, fit a SGM-Ex protective grille.

Required safety technology



- A motor protection switch is needed to fuse the ERM Ex units.
- Maico provides the MVEx... motor protection switch to monitor the maximum motor current for this purpose.
 - Type-examination tested according to Directive 2014/34/EU (ATEX).
 - Installation exclusively in non-explosive areas.

Special versions

- Special voltages are available as special versions on request, at an extra cost.
- Information on operation at temperatures occasionally below -20°C available upon request.
- Feasibility must be checked in each case.

Technical data

Article	Art. No.	U _{nom} V	f _{nom} Hz	Air flow volume m ³ /h	Rotating speed 1/min	P _{nom} W	I _{nom} A	Sound power level L _{WA5} dB(A)	Degree of protection IP	Temperature class	Insulation class	Weight kg
ERM 18 Ex e	0080.0290	230	50	310	2,780	50	0.25	66	54	T4	B	3.6
ERM 22 Ex e	0080.0288	230	50	560	2,860	200	0.92	64	54	T3	B	6.5
ERM 25 Ex e	0080.0249	230	50	870	2,820	300	1.4	77	54	T3	F	7.4



Dimensions [mm]

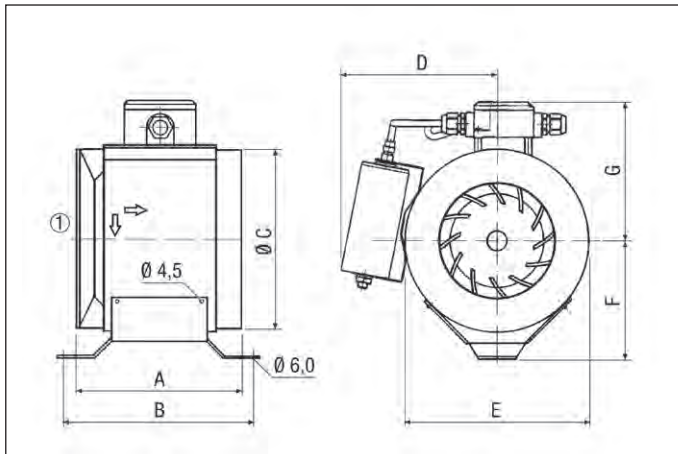

① ERM 22 Ex e: 2 reducers to DN 200 included in scope of delivery. Not shown in dimensional drawing.

Article	A	B	C	D	E	F	G
ERM 18 Ex e	164	187	178	160	183	120	142
ERM 22 Ex e	177	203	224	195	230	140	166
ERM 25 Ex e	205	232	248	210	255	160	180

Characteristic curves for ERM ... Ex e

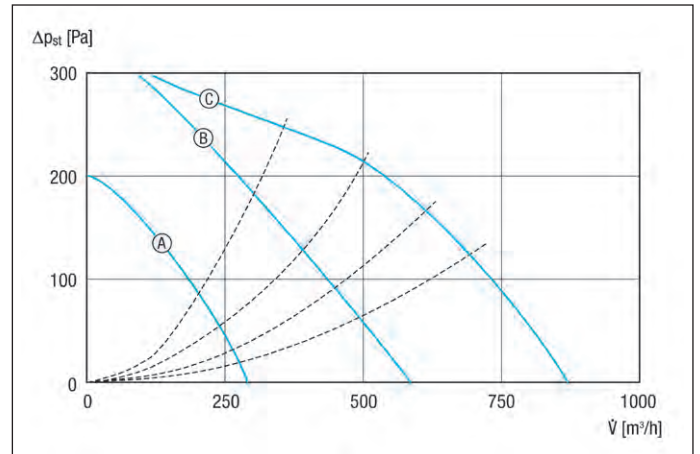

Ⓐ ERM 18 Ex e
 Ⓑ ERM 22 Ex e
 Ⓒ ERM 25 Ex e

Accessories selection table

	ERM 18 Ex e	ERM 22 Ex e	ERM 25 Ex e	see
Specific accessories				
Protective grille	SGM 18 Ex	SGM 22 Ex	SGM 25 Ex	P. 231
Flexible cuff	ELM 10 Ex ELM 12 Ex ELM 18 Ex	ELM 14 Ex ELM 20 Ex	ELM 20 Ex ELM 25 Ex	P. 230
Reducer	REM 18/14 Ex REM 18/12 Ex REM 18/10 Ex	REM 22/18 Ex REM 22/16 Ex REM 22/14 Ex	REM 25/20 Ex REM 25/18 Ex	P. 231
Mounting foot	FUM 15/18	FUM 22	FUM 25	P. 230
Motor protection switch	MVEx 0,4	MVEx 1,0	MVEx 1,6	P. 337

**Mounting feet
FUM**



- Mounting feet for the assembly of ERM fans on walls, ceilings or brackets.
- Horizontal and vertical installation is possible.

Dimensions [mm]

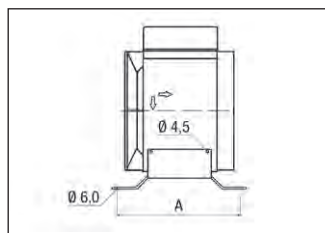

Common features

Material	Sheet steel, galvanised
Installation site	Ceiling/Wall

Article	Art. No.	Nominal size mm
FUM 15/18	0036.0001	150/180
FUM 22	0036.0004	224
FUM 25	0036.0005	250

Article	A mm
FUM 15/18	187
FUM 22	203
FUM 25	232

**Flexible cuffs
ELM/ELM Ex**



- Flexible cuffs for sound and vibration damped assembly of ERM duct fans.
- With 2 tightening straps.
- ELM...: Made of plastic.
- ELM ... Ex: Made of antistatic material, for use in areas subject to explosion hazards.

Dimensions [mm]

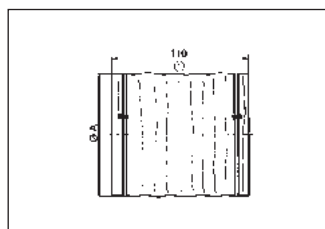

Common features

Colour	Silver grey
Max. ambient temperature	50 °C

Article	Art. No.	Nominal size mm
ELM 10	0092.0121	100
ELM 12	0092.0122	125
ELM 15	0092.0117	150
ELM 18	0092.0158	180
ELM 10 Ex	0092.0261	100
ELM 12 Ex	0092.0262	125
ELM 14 Ex	0092.0246	140
ELM 15 Ex	0092.0244	150
ELM 16 Ex	0092.0247	160
ELM 18 Ex	0092.0245	180
ELM 20 Ex	0092.0248	200
ELM 25 Ex	0092.0249	250

⓪ Extended length

Article	A mm
ELM 10	100
ELM 12	125
ELM 15	150
ELM 18	180
ELM 10 Ex	100
ELM 12 Ex	125
ELM 14 Ex	140
ELM 15 Ex	150
ELM 16 Ex	160
ELM 18 Ex	180
ELM 20 Ex	200
ELM 25 Ex	250

**Reducers
REM/REM Ex**

Article	Art. No.
REM 15/10	0059.0633
REM 18/14	0059.0629
REM 18/12	0059.0628
REM 18/10	0059.0627
REM 18/14 Ex	0055.0304
REM 18/12 Ex	0055.0303
REM 18/10 Ex	0055.0302
REM 22/18 Ex	0055.0307
REM 22/16 Ex	0055.0306
REM 22/14 Ex	0055.0305
REM 25/20 Ex	0055.0309
REM 25/18 Ex	0055.0308

- Reducers for assembly of duct fans in the duct system.
- REM ...: Made of impact-resistant synthetic material.
- REM ... Ex: Made of antistatic material (metal), for use in areas subject to explosion hazards.

Dimensions [mm]

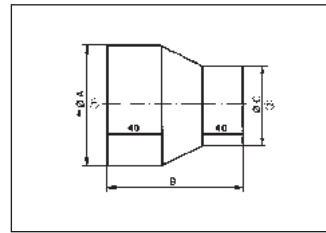

- ⓐ Inside dimension
- ⓑ External dimension

Article	A mm	B mm	C mm
REM 15/10	148	150	98
REM 18/14	177	135	138
REM 18/12	177	155.5	123
REM 18/10	177	190	98
REM 18/14 Ex	179	165	139
REM 18/12 Ex	179	186	124
REM 18/10 Ex	179	220	99
REM 22/18 Ex	225	170	179
REM 22/16 Ex	225	198	159
REM 22/14 Ex	225	225	139
REM 25/20 Ex	249	179	199
REM 25/18 Ex	249	206	179

Common features

Installation site Duct

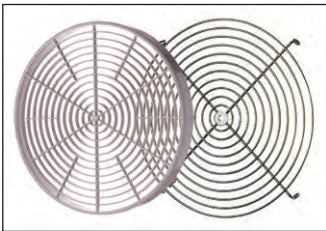
**Protective grilles
SGM/SGM Ex**

Article	Art. No.	Nominal size mm
SGM 15	0059.0425	150
SGM 18	0059.0626	180
SGM 18 Ex	0150.0131	180
SGM 22 Ex	0150.0132	225
SGM 25 Ex	0150.0133	250

- Protective grille for fans in accordance with DIN EN ISO 13857.
- Can be fitted on the inlet or pressure side.
- SGM: Made of impact-resistant synthetic material, pearl white, similar to RAL 1013, for ERM duct fans.
- SGM ... Ex: Made of metal for ERM-Ex fans, for use in areas subject to explosion hazards.

Dimensions [mm]

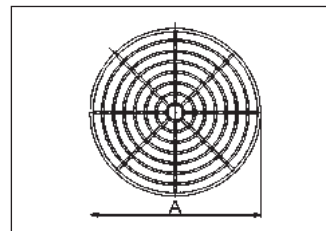

Article	A mm
SGM 15	152
SGM 18	180
SGM 18 Ex	178
SGM 22 Ex	224.5
SGM 25 Ex	249

Common features

Air direction Ventilation and air extraction

ERR centrifugal duct fan



Features

- Centrifugal impeller with backwards curved blades.
- Inlet and outlet side connection couplings for direct installation in ventilation ducts.
- Mounting foot available as accessory.

Mounting instructions

- Can be fitted in any position.
- Use ELR flexible cuffs to prevent transfer of vibrations onto the duct system.

Motor

- External rotor - capacitor motor.
- Operating capacitor in the terminal box is ready to be connected.
- Speed controllable.
- Thermal overload protection as standard feature.
- Robust motor with ball bearings, maintenance-free.
- IP X4 degree of protection when installed in ventilation ducts with at least 1 m of duct on the inlet and outlet sides.

Electrical connection

- Externally fitted terminal box with cable guide bushes.

Safety instructions

- The fan may be operated only if the protection against accidental contact with the impeller is guaranteed to be in accordance with DIN EN ISO 13857 for fans with free inlet or outlet. To do this, fit a SGR protective grille.

Technical data

Article	Art. No.	U _{nom} V	f _{nom} Hz	Air flow volume m ³ /h	Rotating speed 1/min	P _{nom} W	I _{max} A	T _{max} at I _{max} °C	Sound power level L _{WA2} dB(A)	Insulation class	Weight kg
ERR 10/1	0080.0270	230 / 220	50/60	220	2,326	27	0.13	60	49	F	2.8
ERR 10/1 S	0080.0271	230 / 220	50/60	250	2,518	51	0.23	60	52	B	2.8
ERR 12/1	0080.0272	230 / 220	50/60	270	2,336	27	0.13	60	52	F	2.8
ERR 16/1	0080.0273	230 / 220	50/60	350	2,163	29	0.14	60	53	F	2.8
ERR 16/1 S	0080.0274	230 / 220	50/60	720	2,625	112	0.5	60	54	F	4.3
ERR 20/1	0080.0275	230 / 220	50/60	840	2,611	116	0.5	60	60	F	4.4
ERR 25/1	0080.0277	230 / 220	50/60	1,060	2,623	148	0.65	60	60	B	5.6
ERR 31/1	0080.0278	230 / 220	50/60	1,370	2,760	258	1.14	60 ¹⁾	61	F	6.5

¹⁾ At 60 Hz temperature -20°C to 25°C

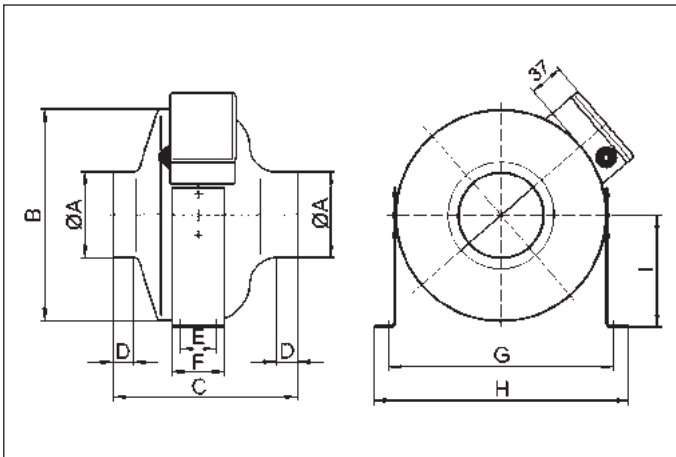

Energy efficiency class for ERR 10/1 S, ERR 16/1 S, ERR 20/1

Dimensions [mm]

Article	A	B	C	D	E	F	G	H	I
ERR 10/1	98	241	210	24	30	50	280	293	125
ERR 10/1 S	98	241	210	24	30	50	280	293	125
ERR 12/1	123	241	230	24	30	50	280	293	125
ERR 16/1	158	241	210	24	30	50	280	293	125
ERR 16/1 S	158	331	232	22	56	80	372	395	185
ERR 20/1	198	335	230	22	56	80	372	395	185
ERR 25/1	248	335	230	22	56	80	372	395	185
ERR 31/1	313	404	295	37	100	130	445	465	225

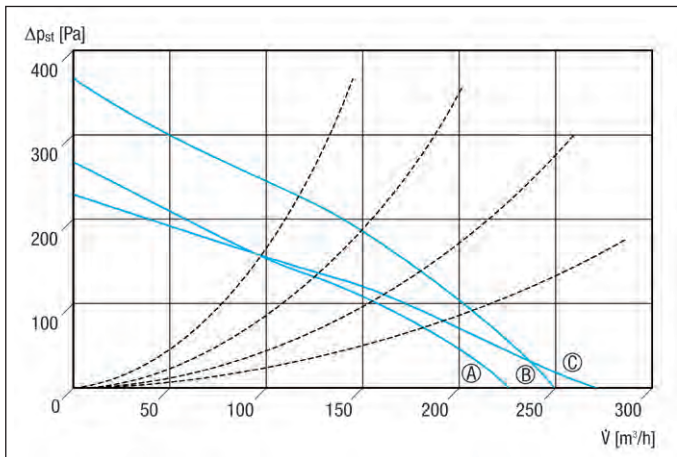
Characteristic curves for ERR 10/1, ERR 10/1 S and ERR 12/1

- Ⓐ ERR 10/1
- Ⓑ ERR 10/1 S
- Ⓒ ERR 12/1

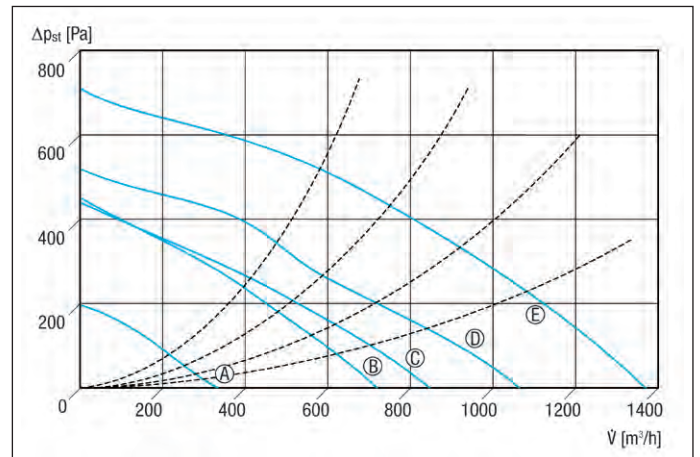
Characteristic curves for ERR 16/1, ERR 16/1 S, ERR 20/1, ERR 25/1 and ERR 31/1

- Ⓐ ERR 16/1
- Ⓑ ERR 16/1 S
- Ⓒ ERR 20/1
- Ⓓ ERR 25/1
- Ⓔ ERR 31/1

Accessories selection table

	ERR 10/1	ERR 10/1 S	ERR 12/1	ERR 16/1	ERR 16/1 S	ERR 20/1	ERR 25/1	ERR 31/1	see
Specific accessories									
Fixing cuff	ELR 10	ELR 10	ELR 12	ELR 16	ELR 16	ELR 20	ELR 25	ELR 31	P. 248
Mounting foot	FUR 10/12/16	FUR 10/12/16	FUR 10/12/16	FUR 10/12/16	FUR 16S/20/25	FUR 16S/20/25	FUR 16S/20/25	FUR 31/1	P. 248
General accessories									
Automatic backflow preventer	AVM 10	AVM 10	AVM 12	AVM 16	AVM 16	AVM 20	AVM 25	AVM 31	P. 249
Protective grille	SGR 10	SGR 10	SGR 12	SGR 16	SGR 16	SGR 20	SGR 25	SGR 31	P. 249
Tubular sound absorber	RSR 10 RSR 10/50	RSR 10 RSR 10/50	RSR 12 RSR 12/50	RSR 16 RSR 16/50	RSR 16 RSR 16/50	RSR 20 RSR 20/50	RSR 25 RSR 25/50	RSR 31 RSR 31/50	P. 250
Electrical air heater	ERH 10-04	ERH 10-04	ERH 12-1	ERH 16-2 DRH 16-5	ERH 16-2 DRH 16-5	ERH 20-2 DRH 20-5	ERH 25-2 DRH 25-6	DRH 31-6	P. 253
Electrical air heater with controller	-	-	-	ERH 16-2 R DRH 16-5 R	ERH 16-2 R DRH 16-5 R	DRH 20-6 R	DRH 25-9 R	DRH 31-12 R	P. 254
Water air heater	WRH 10-1	WRH 10-1	WRH 12-1	WRH 16-2	WRH 16-2	WRH 20-2	WRH 25-4	WRH 25-4 WRH 31-6	P. 255
Air filter	TFE 10-4 TFE 10-5 TFE 10-7	TFE 10-4 TFE 10-5 TFE 10-7	TFE 12-4 TFE 12-5 TFE 12-7	TFE 16-4 TFE 16-5 TFE 16-7	TFE 16-4 TFE 16-5 TFE 16-7	TFE 20-4 TFE 20-5 TFE 20-7	TFE 25-4 TFE 25-5 TFE 25-7	TFE 31-4 TFE 31-5 TFE 31-7	P. 250, P. 251
Speed controller	ST 1 STU 1	ST 1 STU 1	ST 1 STU 1	ST 1 STU 1	ST 1 STU 1	ST 1 STU 1	ST 1 STU 1	ST 1 STU 1	P. 338
Speed controller, distribution board	STS 2,5	STS 2,5	STS 2,5	STS 2,5	STS 2,5	STS 2,5	STS 2,5	STS 2,5	P. 339
5-step transformer	TRE 0,4-2	TRE 0,4-2	TRE 0,4-2	TRE 0,4-2	TRE 0,6-2	TRE 0,6-2	TRE 1,6-2	TRE 1,6-2	P. 340

AWV external wall fan**Features**

- Supply of small to medium air volumes at high resistances.
- Ideal for renovation and retrofitting due to external installation.
- Optimised efficiency, low maintenance costs.
- Centrifugal impellers made from synthetic material, with backwards curved blades.
- Inlet-side mountings for installation in ventilation ducts.
- Integrated shutter.

Mounting instructions

- For installation on the external wall.

Motor

- Capacitor motor.
- Speed controllable.
- Thermal overload protection as standard feature.
- Robust motor with ball bearings, maintenance-free.
- IP X4 degree of protection when installed in ventilation ducts with at least 1 m of duct on the inlet side.

Safety instructions

- The fan can be operated only if the protection against accidental contact with the impeller is guaranteed to be in accordance with DIN EN 13857 for fans with a free inlet.

Technical data

Article	Art. No.	U _{nom} V	f _{nom} Hz	Air flow volume m ³ /h	Rotating speed 1/min	P _{nom} W	I _{max} A	T _{max} at I _{max} °C	Sound power level L _{WA5} dB(A)	Insulation class	Weight kg
AWV 10	0080.0994	230	50	220	2,441	26	0.13	30	60	B	4.4
AWV 15	0080.0996	230	50	340	2,314	55	0.24	40	70	B	4.9
AWV 15 S	0080.0997	230	50	620	2,614	106	0.46	40	74	B	7.6
AWV 20	0080.0998	230	50	650	1,908	116	0.5	40	76	B	7.6
AWV 20 S	0080.0999	230	50	740	2,520	152	0.67	40	77	B	8.3

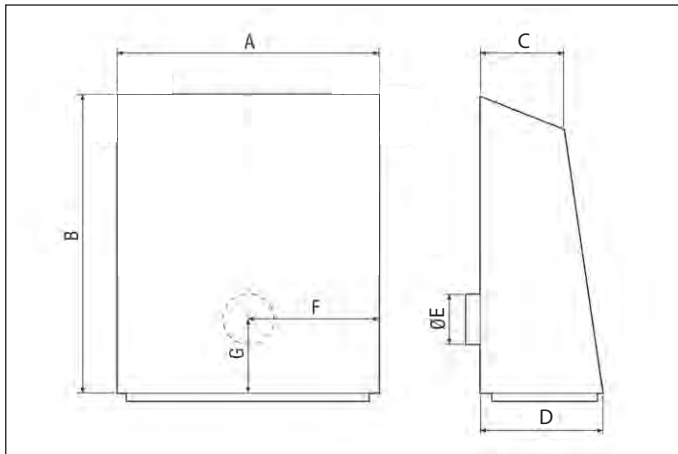
Dimensions [mm]

Article	A	B	C	D	E	F	G
AWV 10	260	355	92	131	98	130	146
AWV 15	260	355	92	131	148	130	146
AWV 15 S	360	450	116	155	148	180	180
AWV 20	360	450	116	155	198	180	180
AWV 20 S	360	450	116	155	198	180	180

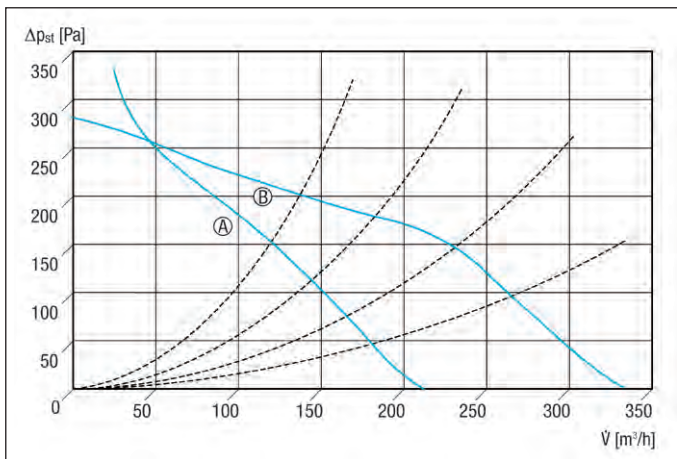
Characteristic curves for AWV 10, AWV 15

Ⓐ AWV 10
Ⓑ AWV 15

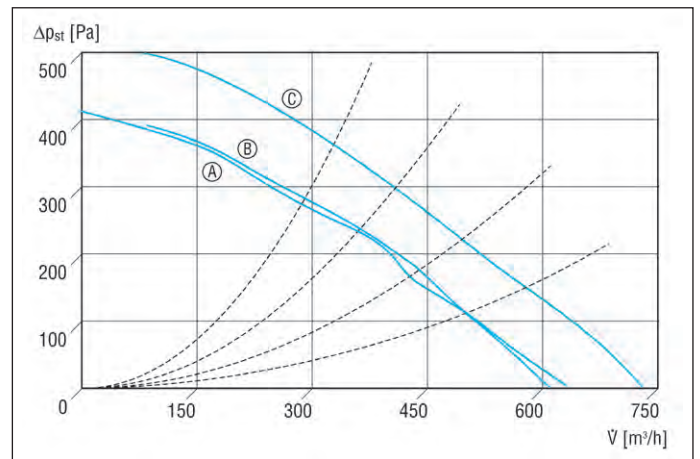
Characteristic curves for AWV 15 S, AWV 20, AWV 20 S

Ⓐ AWV 20
Ⓑ AWV 15 S
Ⓒ AWV 20 S

Accessories selection table

	AWV 10	AWV 15	AWV 15 S	AWV 20	AWV 20 S	see
General accessories						
Tubular sound absorber	RSR 10 RSR 10/50	RSR 15 RSR 15/50	RSR 15 RSR 15/50	RSR 20 RSR 20/50	RSR 20 RSR 20/50	P. 250
Air filter	TFE 10-4 TFE 10-5 TFE 10-7	TFE 15-4 TFE 15-5 TFE 15-7	TFE 15-4 TFE 15-5 TFE 15-7	TFE 20-4 TFE 20-5 TFE 20-7	TFE 20-4 TFE 20-5 TFE 20-7	P. 250, P. 251
Speed controller	ST 1 STU 1	ST 1 STU 1	ST 1 STU 1	ST 1 STU 1	ST 1 STU 1	P. 338
5-step transformer	TRE 0,4-2	TRE 0,4-2	TRE 0,6-2	TRE 0,6-2	TRE 1,6-2	P. 340

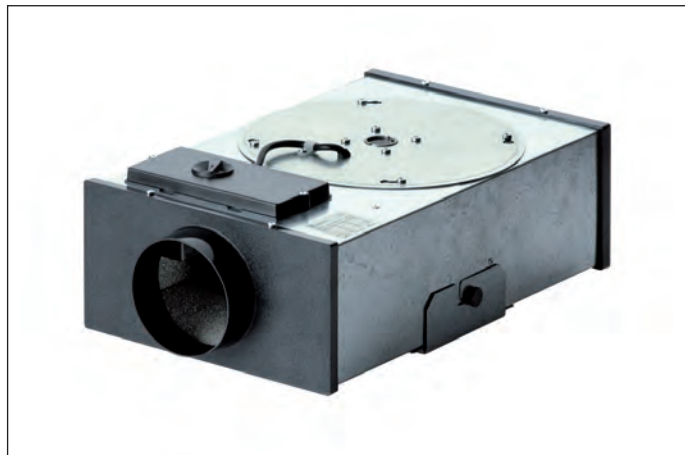
EFR centrifugal flat box**Models**

- EFR 10, EFR 12: 1 speed setting.
- EFR 10 R, EFR 12 R: 5 speed settings; one of the 4 levels can be selected for the base load operation. Level 5 (maximum) is activated by an extra contact, e.g. light switch or hygrostat. The overrun time is set in the unit using a potentiometer (3 - 25 minutes).

Features

- Installation in DN 100 and DN 125 ventilation ducts.
- Smallest dimensions for installation where space is at a premium. Ideal for redevelopments.

- Centrifugal impeller with backwards curved blades.
- Inlet and outlet side connection couplings for direct installation in ventilation ducts.
- IP 20 degree of protection.

Mounting instructions

- Can be fitted in any position.
- With mounting plate for wall and roof installations.

Motor

- Thermal overload protection as standard feature.
- Robust motor with ball bearings, maintenance-free.

Technical data

Article	Art. No.	U _{nom}	f _{nom}	Air flow volume	Rotating speed	P _{nom}	I _{max}	T _{max} at I _{max}	Sound power level	Weight
		V	Hz	m ³ /h	1/min	W	A	°C	L _{WA2} dB(A)	kg
EFR 10	0080.0570	230	50	220	2,373	52	0.23	50	53	4.2
EFR 10 R	0080.0571	230	50	220	2,373	52	0.23	50	53	4.6
EFR 12	0080.0572	230	50	255	2,392	53	0.24	50	55	4.2
EFR 12 R	0080.0573	230	50	255	2,392	53	0.24	50	55	4.7

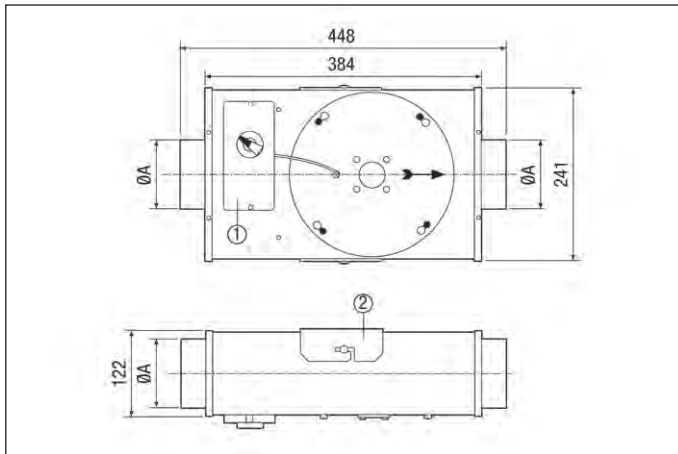
Dimensions [mm]

- ① Electrical connection
② Mounting support

Article	A
EFR 10	100
EFR 10 R	100
EFR 12	121
EFR 12 R	121

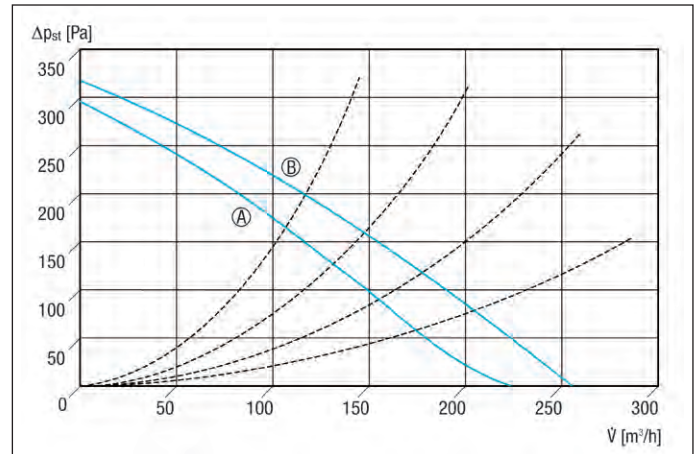
Characteristic curves for EFR

- Ⓐ EFR 10
Ⓑ EFR 12

Accessories selection table

	EFR 10	EFR 10 R	EFR 12	EFR 12 R	see
General accessories					
Automatic backflow preventer	AVM 10	AVM 10	AVM 12	AVM 12	P. 249
External grille	SG 100 SG 100 B	SG 100 SG 100 B	SG 120	SG 120	P. 303
Fly screen	FG 100	FG 100	FG 120	FG 120	P. 303
Disk valve, synthetic material	TK	TK	TK	TK	P. 316
Disk valve, metal	TM TFA TFZ	TM TFA TFZ	TM TFA TFZ	TM TFA TFZ	P. 316, P. 317
Disk valve, stainless steel	TM-V2A	TM-V2A	TM-V2A	TM-V2A	P. 316
Disk valve, fire protection	TB, WBV	TB, WBV	TB, WBV	TB, WBV	P. 317
Mounting frame for TFA/TFZ	EBR-D	EBR-D	EBR-D	EBR-D	P. 318
Supply air valve	ZWVQ 10 ZWVQ 12	ZWVQ 10 ZWVQ 12	ZWVQ 10 ZWVQ 12	ZWVQ 10 ZWVQ 12	P. 319
Exhaust and supply air valve	AZV 100	AZV 100	AZV 100	AZV 100	P. 315
Flexible aluminium duct	AFR 100	AFR 100	AFR 125	AFR 125	P. 319
Slide-in sound absorber	SDE 8 SDE 10 SDE 12	SDE 8 SDE 10 SDE 12	SDE 8 SDE 10 SDE 12	SDE 8 SDE 10 SDE 12	P. 321
Thermostat	THR 10 TH 10 TH 16	THR 10 TH 10 TH 16	THR 10 TH 10 TH 16	THR 10 TH 10 TH 16	P. 343, P. 344
Hygrostat	HY 230 HY 230 I	HY 230 HY 230 I	HY 230 HY 230 I	HY 230 HY 230 I	P. 348
Air quality controller	EAQ 10/1	EAQ 10/1	EAQ 10/1	EAQ 10/1	P. 349

ESR -2 EC sound-insulated ventilation box



Features

- Low energy consumption thanks to EC technology.
- Low power consumption especially in control range.
- Quick economical installation with standard fixing bracket.
- Removable housing cover with clip-locks.
- Inlet and outlet side connection socket for direct installation in ventilation ducts.
- With 40 mm sound absorbing rock wool, laminated with silk glass, to meet the increased requirements of especially low noise levels.
- Centrifugal impellers with blades bent forwards with ESR 12-2 EC and ESR 16-2 EC.
- Centrifugal impellers with blades bent backwards with ESR 20-2 EC, ESR 25-2 EC and ESR 31-2 EC.
- Simple cleaning thanks to hinged cover.

Mounting information

- Can be fitted in any position.

Motor

- DC motor.
- Robust motor with ball bearings, maintenance-free.
- Insulation class B.
- IP X4 degree of protection with closed housing cover.

Electrical connection

- Terminal box at front.

Safety instructions

- The fan may be operated only if the protection against accidental contact with the impeller is guaranteed to be in accordance with DIN EN ISO 13857 for fans with free inlet or outlet. To do this, fit a protective grille.

Technical data

Article	Art. No.	U _{nom} V	f _{nom} Hz	Air flow volume m ³ /h	Rotating speed 1/min	P _{nom} W	I _{nom} A	I _{max} A	T _{max} at I _{max} °C	Sound power level L _{WA2} dB(A)	Insulation class	Weight kg
ESR 12-2 EC	0080.0710	230	50	350	1,960	29	0.23	0.3	50	48	B	12
ESR 16-2 EC	0080.0711	230	50	430	1,960	35	0.25	0.35	50	50	B	12
ESR 20-2 EC	0080.0712	230	50	700	4,360	127	0.97	1	50	67	B	20
ESR 25-2 EC	0080.0713	230	50	1,190	3,210	204	1.4	1.4	50	65	B	18
ESR 31-2 EC	0080.0714	230	50	2,050	3,670	538	2.1	2.1	50	70	B	26

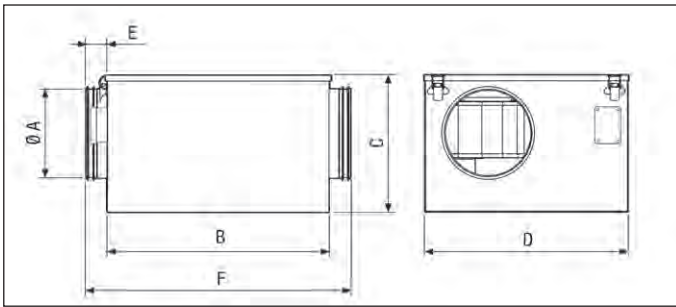

Dimensions [mm]

Article	A	B	C	D	E	F
ESR 12-2 EC	120	380	230	380	35	450
ESR 16-2 EC	155	380	230	380	35	450
ESR 20-2 EC	195	380	285	380	35	480
ESR 25-2 EC	245	460	285	480	60	580
ESR 31-2 EC	310	510	385	540	50	610

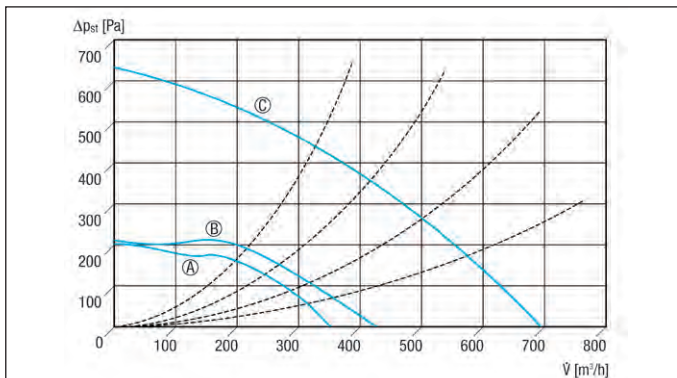
Characteristic curves for ESR 12-2 EC, ESR 16-2 EC and ESR 20-2 EC

Ⓐ ESR 12-2 EC Ⓑ ESR 16-2 EC Ⓒ ESR 20-2 EC

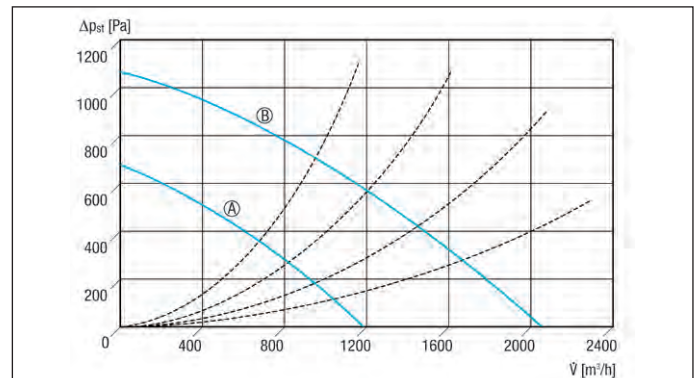
Characteristic curves for ESR 25-2 EC and ESR 31-2 EC

Ⓐ ESR 25-2 EC Ⓑ ESR 31-2 EC

Accessories selection table

	ESR 12-2 EC	ESR 16-2 EC	ESR 20-2 EC	ESR 25-2 EC	ESR 31-2 EC	see
Specific accessories						
Sound insulation set	KSD-D	KSD-D	KSD-D	KSD-D	KSD-D	P. 239
General accessories						
Automatic backflow preventer	AVM 12	AVM 16	AVM 20	AVM 25	AVM 31	P. 249
Protective grille	SGR 12	SGR 16	SGR 20	SGR 25	SGR 31	P. 249
Tubular sound absorber	RSR 12 RSR 12/50	RSR 16 RSR 16/50	RSR 20 RSR 20/50	RSR 25 RSR 25/50	RSR 31 RSR 31/50	P. 250
Electrical air heater	ERH 12-1	ERH 16-2 DRH 16-5	ERH 20-2 DRH 20-5	ERH 25-2 DRH 25-6	–	P. 253
Electrical air heater with controller	–	ERH 16-2 R DRH 16-5 R	DRH 20-6 R	DRH 25-9 R	DRH 31-12 R	P. 254
Water air heater	WRH 12-1	WRH 16-2	WRH 20-2	WRH 25-4	WRH 31-6	P. 255
Air filter	TFE 12-4 TFE 12-5 TFE 12-7	TFE 16-4 TFE 16-5 TFE 16-7	TFE 20-4 TFE 20-5 TFE 20-7	TFE 25-4 TFE 25-5 TFE 25-7	TFE 31-4 TFE 31-5 TFE 31-7	P. 250, P. 251
Potentiometer	ST EC 010 ST EC 230 ST EC 3	ST EC 010 ST EC 230 ST EC 3	ST EC 010 ST EC 230 ST EC 3	ST EC 010 ST EC 230 ST EC 3	ST EC 010 ST EC 230 ST EC 3	P. 337
Pressure and temperature control system	EAT EC	EAT EC	EAT EC	EAT EC	EAT EC	P. 345

Accessorie ESR -2 EC
Sound insulation set KSD-D



Article	Art. No.
KSD-D	0092.0521

- 4 rubber damping elements with galvanised shim for structure-borne sound-insulated ceiling mounting of ESR -2 EC ventilation boxes in accordance with DIN 4109.
- Other mounting material such as threaded rods, nuts etc. are not included in the scope of supply.

Features

Material	Thermoplastic elastomer (TPE)
Colour	Black
Ambient temperature:	–50 °C up to 110 °C
Packing unit	4 pieces
Thread	M8
Fire protection	Fire class B2 according to DIN 4102, non-dripping

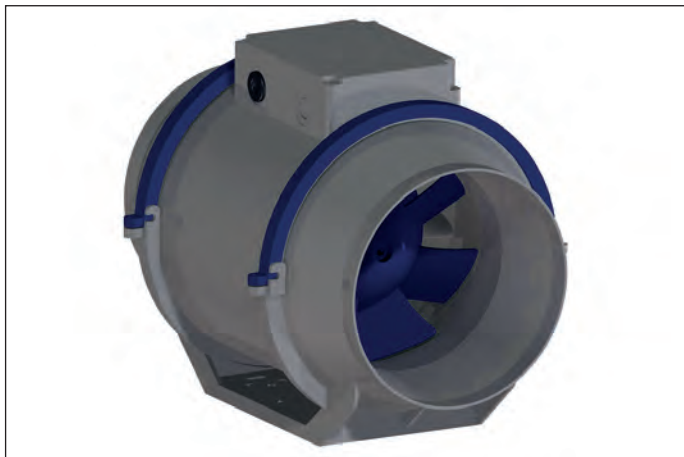
HDR diagonal fan



Features

- New product, available from 4th quarter of 2017.
- Highly efficient duct fan, made from high-quality plastic, including integrated mounting console.
- Powerful diagonal impeller with downstream stator for high output.
- Modular design with optimised flow technology and acoustics.
- Reduced space requirement due to compact dimensions.

- For direct installation between ducts.
- Connection sockets on the outlet and inlet sides correspond to the prevailing standard duct diameters.
- Easy inspection and maintenance by simply opening the clamp and removing the fan.
- IP 44 degree of protection.

Mounting instructions

- Can be fitted in any position.

AC motor

- Series HDR.
- 3 stages with controllable speed, option of controlling speed using phase angle or transformer.
- Thermal overload protection as a standard feature.
- Robust motor with humidity protection and ball bearing, maintenance-free,
- Thermal class 130 (B).

EC motor

- Series HDR EC.
- Highly efficient EC internal rotor motor.
- Speed controllable 3-level.
- Thermal overload protection as a standard feature.
- Robust motor with humidity protection and ball bearing, maintenance-free.
- Thermal class 130 (B).

Electrical connection

- Externally fitted terminal box with cable entry grommet.

Safety instructions

- The fan may be operated only if the protection against accidental contact with the impeller is guaranteed to be in accordance with DIN EN ISO 13857 for fans with free inlet or free outlet. To do this, fit a SGR protective grille.

Technical data

Article	Art. No.	U _{nom} V	f _{nom} Hz	Air flow volume m ³ /h	Rotating speed 1/min	P _{nom} W	I _{nom} A	I _{max} A	Sound power level L _{WA5} dB(A)	Insulation class	Weight kg
HDR 10	0080.0536	230	50	326	2,705	37.7 ¹⁾	0.15 ¹⁾	0.17	60.5	B	2.5
HDR 10 EC	0080.0540	230	50/60	326	2,430	18 ¹⁾	0.15 ¹⁾	0.21	61	B	1.7
HDR 12	0080.0537	230	50	462	2,682	39.3 ¹⁾	0.16 ¹⁾	0.18	61	B	2.5
HDR 12 EC	0080.0541	230	50/60	500	2,430	25.7 ¹⁾	0.21 ¹⁾	0.27	61.5	B	1.7
HDR 15	0080.0538	230	50	655	2,834	52.2 ¹⁾	0.21 ¹⁾	0.23	64	B	2.5
HDR 15 EC	0080.0542	230	50/60	639	2,680	36 ¹⁾	0.3 ¹⁾	0.37	64	B	1.7
HDR 16	0080.0539	230	50	684	2,834	55.4 ¹⁾	0.22 ¹⁾	0.23	64.5	B	2.5
HDR 16 EC	0080.0543	230	50/60	662	2,680	36.5 ¹⁾	0.31 ¹⁾	0.37	64.5	B	1.7

¹⁾ In opt. efficiency

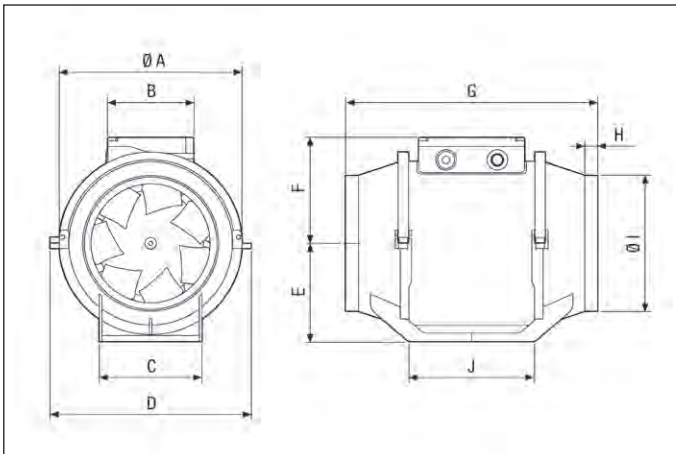
Dimensions [mm]

Article	A	B	C	D	E	F	G	H	I	J
HDR 10	214	100	120	235	115	129.5	295	15	99	147
HDR 10 EC	214	100	120	235	115	129.5	295	15	99	147
HDR 12	214	100	120	235	115	129.5	295	15	124	147
HDR 12 EC	214	100	120	235	115	129.5	295	15	124	147
HDR 15	214	100	120	235	115	129.5	295	15	149	147
HDR 15 EC	214	100	120	235	115	129.5	295	15	149	147
HDR 16	214	100	120	235	115	129.5	295	15	159	147
HDR 16 EC	214	100	120	235	115	129.5	295	15	159	147

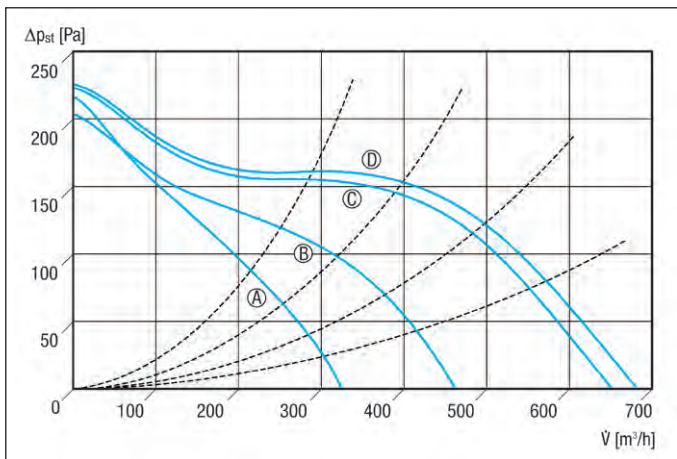
Characteristic curves for HDR

- Ⓐ HDR 10
- Ⓑ HDR 12
- Ⓒ HDR 15
- Ⓓ HDR 16

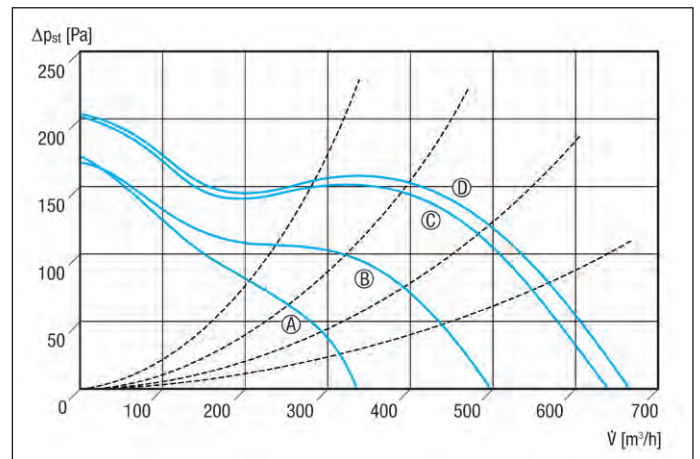
Characteristic curves for HDR EC

- Ⓐ HDR 10 EC
- Ⓑ HDR 12 EC
- Ⓒ HDR 15 EC
- Ⓓ HDR 16 EC

Accessories selection table

	HDR 10	HDR 10 EC	HDR 12	HDR 12 EC	HDR 15	HDR 15 EC	HDR 16	HDR 16 EC	see
General accessories									
Automatic backflow preventer	AVM 10	AVM 10	AVM 12	AVM 12	AVM 15	AVM 15	AVM 16	AVM 16	P. 249
Protective grille	SGR 10	SGR 10	SGR 12	SGR 12	–	–	SGR 16	SGR 16	P. 249
Tubular sound absorber	RSR 10 RSR 10/50	RSR 10 RSR 10/50	RSR 12 RSR 12/50	RSR 12 RSR 12/50	RSR 15 RSR 15/50	RSR 15 RSR 15/50	RSR 16 RSR 16/50	RSR 16 RSR 16/50	P. 250
Electrical air heater	ERH 10-04	ERH 10-04	ERH 12-1	ERH 12-1	–	–	ERH 16-2	ERH 16-2	P. 253
Water air heater	WRH 10-1	WRH 10-1	WRH 12-1	WRH 12-1	–	–	WRH 16-2	WRH 16-2	P. 255
Air filter	TFE 10-4 TFE 10-5 TFE 10-7	TFE 10-4 TFE 10-5 TFE 10-7	TFE 12-4 TFE 12-5 TFE 12-7	TFE 12-4 TFE 12-5 TFE 12-7	TFE 15-4 TFE 15-5 TFE 15-7	TFE 15-4 TFE 15-5 TFE 15-7	TFE 16-4 TFE 16-5 TFE 16-7	TFE 16-4 TFE 16-5 TFE 16-7	P. 250, P. 251
3-step switch	DS 3N	–	DS 3N	–	DS 3N	–	DS 3N	–	P. 342
Room air control	–	RLS 3	–	RLS 3	–	RLS 3	–	RLS 3	P. 255
Speed controller	ST 1 STU 1	–	ST 1 STU 1	–	ST 1 STU 1	–	ST 1 STU 1	–	P. 338
Speed controller, distribution board	STS 2,5	–	STS 2,5	–	STS 2,5	–	STS 2,5	–	P. 339
5-step transformer	TRE 0,4-2	–	TRE 0,4-2	–	TRE 0,4-2	–	TRE 0,4-2	–	P. 340

ERK diagonal fan



Features

- Duct fan, made of polypropylene.
- Connection sockets on the outlet and inlet sides correspond to a folded spiral-seams duct diameter.
- For direct installation between ducts.
- Easy inspection and maintenance by simply opening the clamp and removing the fan.
- Diagonal impeller with down-stream stator (exception: ERK 100, axial impeller).

Motor

- Asynchronous motor, 1, 2 or 3 levels, depending on model.
- IP 44 degree of protection.
- Robust motor with ball bearings, maintenance-free.

- Speed control using phase control or transformer possible (exception: Version T and ST).
- There can be a physically induced humming noise, through the use of phase angle technology. 5-step transformers are therefore used for speed control in rooms requiring quiet fan operations.
- Thermal overload protection as a standard feature.

Electrical connection

- Externally fitted terminal box with cable entry grommet.

Safety instructions

- The fan may be operated only if the protection against accidental contact is guaranteed to be in accordance with DIN EN ISO 13857 for fans with free inlet and outlet. To do this, fit a SGR protective grille.

Models

- ERK... Standard model.
- ERK... S: particularly powerful model.
- ERK... T and ERK... ST: Model with follow-up relay, adjustable from 3 to 15 minutes.

Technical data

Article	Art. No.	U _{nom}	f _{nom}	Air flow volume m ³ /h	Rotating speed 1/min	P _{nom}	I _{max}	T _{max}	Sound power level L _{WA5} dB(A)	Insulation class	Weight kg
		V	Hz			W	A	°C			
ERK 100	0080.0173	230	50	130	2,200	25	0.16	40	45	B	1
ERK 100 T	0080.0174	230	50	130	2,200	25	0.16	40	45	B	1.1
ERK 100 S	0080.0175	230	50	160/250	1,700/2,300	18/30	0.1/0.18	40	55	B	2
ERK 100 ST	0080.0176	230	50	160/250	1,700/2,300	18/30	0.1/0.18	40	55	B	2
ERK 125	0080.0177	230	50	180/300	1,700/2,300	18/30	0.1/0.18	40	54	B	2
ERK 125 T	0080.0178	230	50	180/300	1,700/2,300	18/30	0.1/0.18	40	54	B	2.1
ERK 150	0080.0179	230	50	340/480	2,000/2,700	60/80	0.27/0.36	40	66	B	2.4
ERK 160	0080.0180	230	50	340/500	2,000/2,700	60/80	0.27/0.36	40	65	B	2.5
ERK 200	0080.0181	230	50	720/820/910	1,800/2,000/2,700	55/65/85	0.24/0.27/0.34	40	58	B	3.2

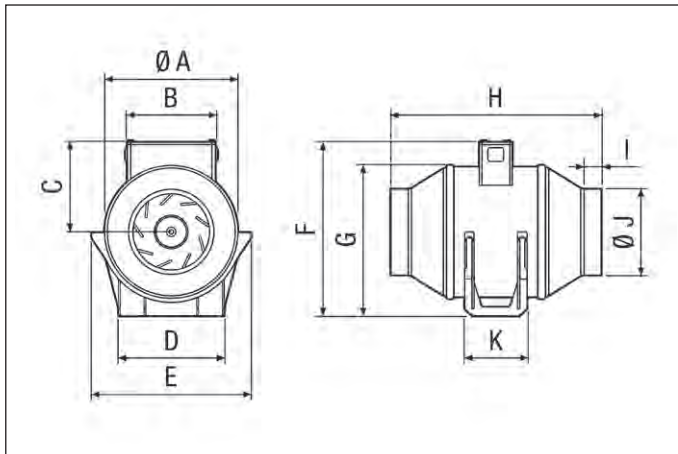
Dimensions [mm] for ERK 100 and ERK 100 T

Article	A	B	C	D	E	F	G	H	I	J	K
ERK 100	152	100	102.5	120	171	196	171.5	238	20	98	71
ERK 100 T	152	100	102.5	120	171	196	171.5	238	20	98	71

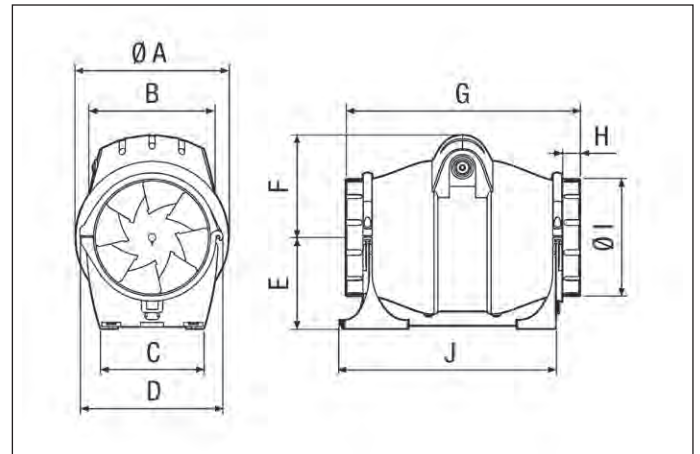
Dimensions [mm] for ERK 100 S to ERK 200

Article	A	B	C	D	E	F	G	H	I	J
ERK 100 S	168	155	130	180	115	117	315	25	98	241.6
ERK 100 ST	168	155	130	180	115	117	315	25	98	241.6
ERK 125	168	155	130	180	115	117	279	25	122	241.6
ERK 125 T	168	155	130	180	115	117	279	25	122	241.6
ERK 150	192	158	130	180	115	129	293.4	21	147	272.4
ERK 160	192	158	130	180	115	129	312.6	23	157	272.4
ERK 200	211	161.5	142	230	140	138.5	353.6	51.5	197	272.4

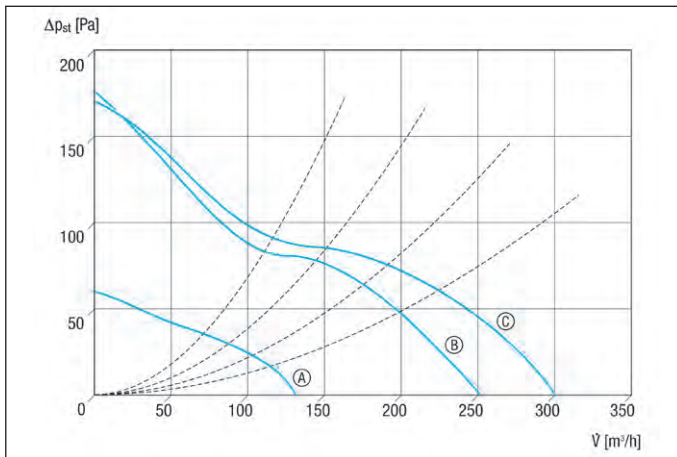
Characteristic curves for DN 100 and DN 125

- Ⓐ ERK 100, ERK 100 T
- Ⓑ ERK 100 S, ERK 100 ST
- Ⓒ ERK 125, ERK 125 T

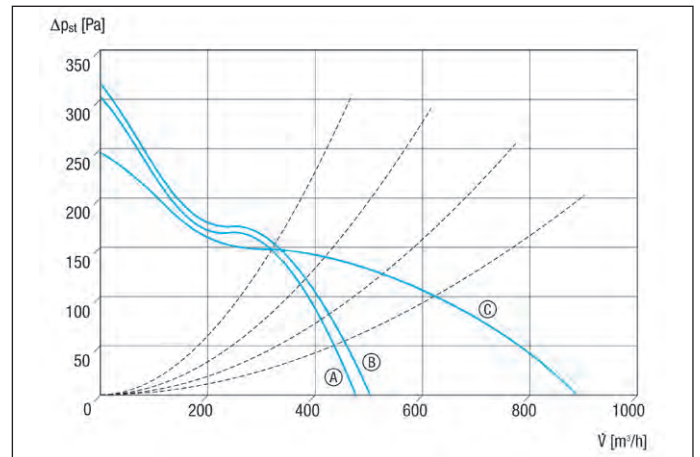
Characteristic curves for DN 150 to DN 200

- Ⓐ ERK 150
- Ⓑ ERK 160
- Ⓒ ERK 200

Accessories selection table

	ERK 100	ERK 100 T	ERK 100 S	ERK 100 ST	ERK 125	ERK 125 T	ERK 150	ERK 160	ERK 200	see
General accessories										
Automatic backflow preventer	AVM 10	AVM 10	AVM 10	AVM 10	AVM 12	AVM 12	AVM 15	AVM 16	AVM 20	P. 249
Protective grille	SGR 10	SGR 10	SGR 10	SGR 10	SGR 12	SGR 12	–	SGR 16	SGR 20	P. 249
Electrical air heater	ERH 10-04	ERH 10-04	ERH 10-04	ERH 10-04	ERH 12-1	ERH 12-1	–	ERH 16-2	ERH 20-2	P. 253
Water air heater	WRH 10-1	WRH 10-1	WRH 10-1	WRH 10-1	WRH 12-1	WRH 12-1	–	WRH 16-2	WRH 20-2	P. 255
Air filter	TFE 10-4 TFE 10-5 TFE 10-7	TFE 10-4 TFE 10-5 TFE 10-7	TFE 10-4 TFE 10-5 TFE 10-7	TFE 10-4 TFE 10-5 TFE 10-7	TFE 12-4 TFE 12-5 TFE 12-7	TFE 12-4 TFE 12-5 TFE 12-7	TFE 15-4 TFE 15-5 TFE 15-7	TFE 16-4 TFE 16-5 TFE 16-7	TFE 20-4 TFE 20-5 TFE 20-7	P. 250, P. 251
Speed controller	ST 1 STU 1	–	ST 1 STU 1	–	ST 1 STU 1	–	ST 1 STU 1	ST 1 STU 1	ST 1 STU 1	P. 338
Speed controller, distribution board	–	–	–	–	–	–	STS 2,5	STS 2,5	STS 2,5	P. 339
5-step transformer	TRE 0,4-2	–	TRE 0,4-2	TRE 0,4-2	TRE 0,4-2	–	TRE 0,4-2	TRE 0,4-2	TRE 0,4-2	P. 340

EDR diagonal fan



Features

- For direct installation in ducts.
- Displacement of medium to large air volumes against high levels of resistance.
- Compact dimensions, low weight and integrated installation plate simplify fast installation.
- High efficiency reduces operating costs: Depending on level of use, purchase price is amortised after just one year.
- Suction nozzle for turbulence-reduced air intake.

- Diagonal impeller with down-stream stator.
- Profiled impeller and stator blades ensure optimum flow.
- With diffuser to increase static pressure.
- Gap sealing between intake and pressure chamber reduces over-flow losses.
- Meridian flow course prevents turbulence.
- IP X4 degree of protection. Exception EDR 45 to EDR 56 IP 54.
- Insulation class F.

Three-phase AC motor

- Continuously variable speed control using MFU frequency converter.
- They can also be connected to the mains directly.
- The terminal connections must be connected to a motor protection switch.
- Electrical connection via connecting cable.

Electrical connection

- 50 Hz power frequency.

AC motor

- Electrical connection via external terminal box.
- Speed can be controlled using transformers.
- Thermal overload protection as a standard feature.
- Depending on versions, thermal contacts must be connected to an MVE 10 full motor protection switch or the control circuit of a contactor.

Technical data for units > 125 W according to ErP in Best Efficiency Point (BEP)

Article	Art. No.	U _{nom} V	f _{nom} Hz	Air flow volume m ³ /h	Sound power level L _{WAS} dB(A)	Air volume v _{nom} m ³ /h	Pressure p _{fs, nom} Pa	Speed n _{nom} 1/min	P _{nom} W	I _{nom} A	I _{max} A	T _{max} at I _{max} °C	Weight kg	Efficiency level N	Total efficiency η %
EDR 25	0080.0656	230	50	1,700	71	1,119 ¹⁾	274 ¹⁾	2,824 ¹⁾	170 ¹⁾	0.8 ¹⁾	1	55	6.5	63.4	44.9
EDR 31	0080.0657	230	50	3,400	76	2,243 ¹⁾	466 ¹⁾	2,776 ¹⁾	460 ¹⁾	2.3 ¹⁾	3.2	70	14.9	66.2	52.7
EDR 35	0080.0658	230	50	5,000	79	3,173 ¹⁾	572 ¹⁾	2,776 ¹⁾	860 ¹⁾	4.2 ¹⁾	5.4	45	17.1	61.2	50.5
EDR 40	0080.0660	230	50	3,440	74	2,419 ¹⁾	158 ¹⁾	1,440 ¹⁾	200 ¹⁾	0.9 ¹⁾	1.5	80	12.8	63.4	45.8
EDR 45	0080.0661	230	50	5,200	71	3,500 ¹⁾	246 ¹⁾	1,435 ¹⁾	410 ¹⁾	2.3 ¹⁾	3.1	80	17.5	64.2	50
EDR 50	0080.0662	230	50	6,720	75	4,736 ¹⁾	302 ¹⁾	1,352 ¹⁾	640 ¹⁾	3.3 ¹⁾	3.7	80	22.8	60.5	48.7
EDR 56	0080.0663	400	50	10,380	85	6,578 ¹⁾	395 ¹⁾	1,542 ¹⁾	1,230 ¹⁾	2.5 ¹⁾	2.8	80	22.8	68	58.6
EDR 63	0080.0664	400	50	15,880	88	10,505 ¹⁾	600 ¹⁾	1,556 ¹⁾	2,290 ¹⁾	5.1 ¹⁾	5.4	70	35.5	64.3	70.2
EDR 71	0080.0665	400	50	20,240	91	12,313 ¹⁾	705 ¹⁾	1,416 ¹⁾	3,330 ¹⁾	6.9 ¹⁾	7.7	55	47	66.2	70.9

¹⁾ In opt. efficiency

BEP measured in measurement category A, static efficiency category. For further ErP data, go online.

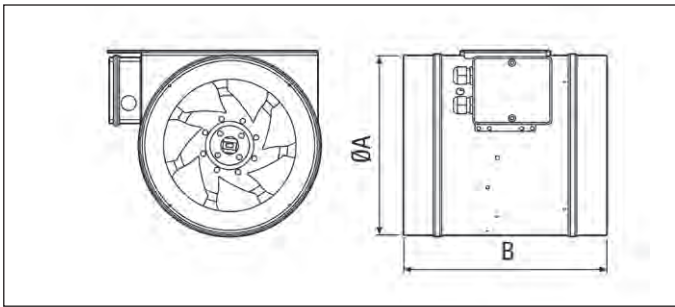

Dimensions [mm]

Article	A	B
EDR 25	250	278
EDR 31	315	351
EDR 35	354	396
EDR 40	403	416
EDR 45	453	467
EDR 50	504	515
EDR 56	564	582
EDR 63	634	654
EDR 71	714	732

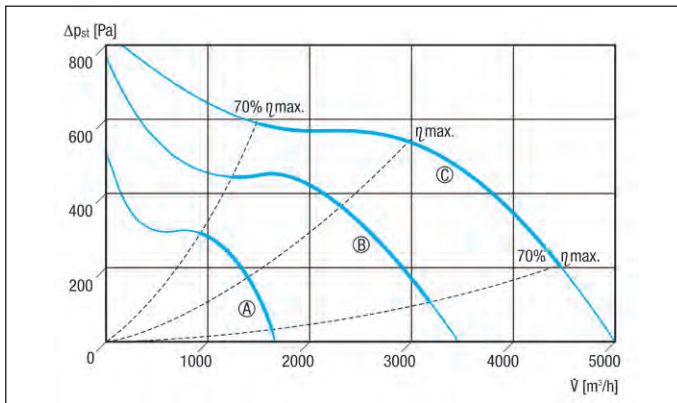
Characteristic curves for EDR 25, EDR 31 and EDR 35

Ⓐ EDR 25 Ⓑ EDR 31 Ⓒ EDR 35

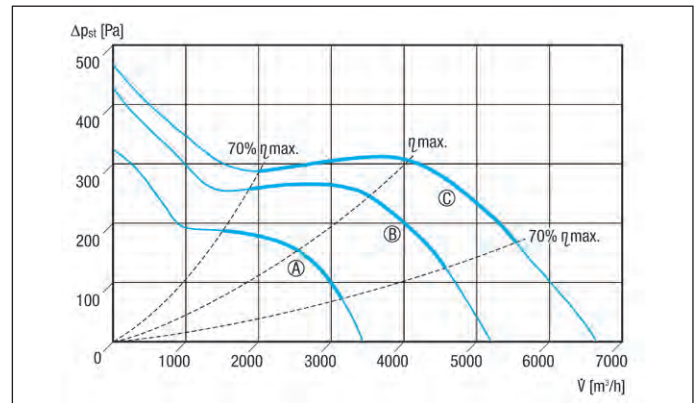
Characteristic curves for EDR 40, EDR 45 and EDR 50

Ⓐ EDR 40 Ⓑ EDR 45 Ⓒ EDR 50

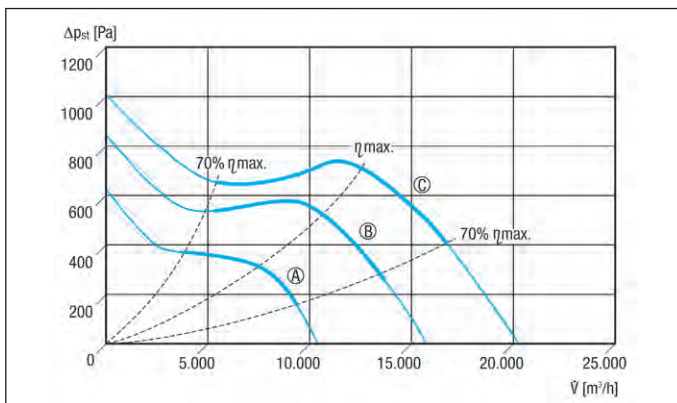
Characteristic curves for EDR 56, EDR 63 and EDR 71

Ⓐ EDR 56 Ⓑ EDR 63 Ⓒ EDR 71

Accessories selection table

	EDR 25	EDR 31	EDR 35	EDR 40	EDR 45	EDR 50	EDR 56	EDR 63	EDR 71	see
General accessories										
Control shutter	JRE 25	–	JRE 35	JRE 40	–	JRE 50	–	–	–	P. 300
Servomotor	MS 8 MS 8 P	MS 8 MS 8 P	MS 8 MS 8 P	MS 8 MS 8 P	–	MS 8 MS 8 P	–	–	–	P. 302
Automatic backflow preventer	AVM 25	AVM 31	AVM 35	AVM 40	–	–	–	–	–	P. 249
Flexible cuff	EL 25	EL 30	EL 35	EL 40	EL 45	EL 50	–	–	–	P. 248
Tubular sound absorber	RSR 25 RSR 25/50	RSR 31 RSR 31/50	RSR 35/50	RSR 40/50	–	–	–	–	–	P. 250
Motor protection switch	–	–	–	–	MVE 10	MVE 10	–	–	–	P. 336
Frequency converter	–	–	–	–	–	–	MFU 4	MFU 10	MFU 14	P. 339
5-step transformer	TRE 1,6-2	TRE 3,3-2	TRE 6,5-2	TRE 1,6-2	TRE 3,3-2	TRE 6,5-2	–	–	–	P. 340
5-step transformer, control cabinet	TRE 1,6 S-2	TRE 3,3 S-2	TRE 6,5 S-2	TRE 1,6 S-2	TRE 3,3 S-2	TRE 6,5 S-2	–	–	–	P. 341
5-step switch for TRE...S -2/ TR...S-2 5-step transformer	ESS 20	ESS 20	ESS 20	ESS 20	ESS 20	ESS 20	–	–	–	P. 341

EKR -2 sound-insulated ventilation box



- Motor located outside of the air flow.
- With condensation drain if the exhaust socket points upwards.
- Strong centrifugal impellers with backward curved blades.

Motor

- Motor can be regulated by transformers using voltage reduction.
- Terminal connections for thermal contacts.
- Motor protection through an external MAICO MVE 10 triggering device.
- IP X4 degree of protection for closed housing covers as well as duct connections fitted on the inlet and outlet sides.

Mounting instructions

- Installation with upward, right-hand or left-hand exhaust sockets.
- If the unit is mounted with the exhaust socket pointing to the left or the right, the service door must be altered by the customer.

Electrical connection

- Externally fitted terminal box with cable screw-connection.

Safety instructions

- The fan may be operated only if the protection against accidental contact with the impeller is guaranteed to be in accordance with DIN EN ISO 13857 for fans with free inlet or outlet. To do this, fit a protective grille.

Features

- The series was developed especially for the tough operating conditions of a kitchen exhaust air fan.
- Double-walled housing made of galvanised sheet steel, for high demands and especially low noise levels.
- Supply of medium to large air volumes at high resistances.
- Not sensitive to hot airstreams of up to 120° C.
- Inlet and outlet side connection sockets for direct installation in ventilation ducts, with double sealed lips.
- With mounting track and 4 vibration dampers.
- Fan unit can be swivelled out for cleaning and maintenance.

Technical data for units > 125 W according to ErP in Best Efficiency Point (BEP)

Article	Art. No.	U _{nom} V	f _{nom} Hz	Air flow volume m ³ /h	Sound power level L _{WA5} dB(A)	Air volume _{nom} m ³ /h	Pressure P _{fs, nom} Pa	Speed n _{nom} 1/min	P _{nom} W	I _{nom} A	I _{max} A	T _{max} at I _{max} °C	Weight kg	Efficiency level N	Total efficiency η %
EKR 20-2	0080.0882	230	50	1,650	73	873 ¹⁾	516 ¹⁾	2,837 ¹⁾	260 ¹⁾	1.1 ¹⁾	1.8	120	29	62.9	46.1
EKR 25-2	0080.0883	230	50	2,500	78	1,518 ¹⁾	581 ¹⁾	2,844 ¹⁾	450 ¹⁾	2 ¹⁾	3.2	120	37.8	65.8	51.6
EKR 31-2	0080.0884	230	50	3,400	80	1,934 ¹⁾	716 ¹⁾	2,723 ¹⁾	722 ¹⁾	3.2 ¹⁾	4.1	120	47.5	62.9	50.8
EKR 35-2	0080.0885	230	50	5,800	75	2,877 ¹⁾	493 ¹⁾	1,359 ¹⁾	850 ¹⁾	3.8 ¹⁾	4.7	120	70	61	48.5
EKR 40-2	0080.0886	230	50	7,750	79	3,676 ¹⁾	601 ¹⁾	1,368 ¹⁾	1,340 ¹⁾	5.9 ¹⁾	7.7	120	110	58	48.1

¹⁾ In opt. efficiency

BEP measured in measurement category A, static efficiency category. For further ErP data, go online.

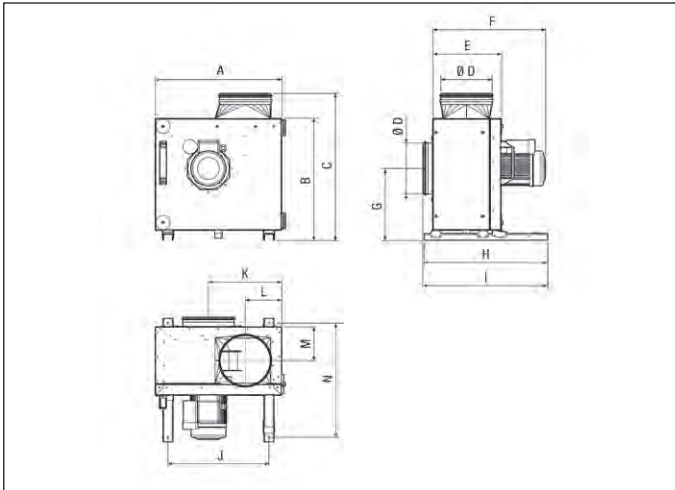
Dimensions [mm]

Article	A	B	C	D	E	F	G	H	I	J	K	L	M	N
EKR 20-2	492	474	571	199	265	475	279	480	485	394	285	142	131	445
EKR 25-2	592	561	687	249	315	548	329	540	567	494	344	167	156	505
EKR 31-2	592	561	692	314	315	567	329	540	568	494	344	200	156	505
EKR 35-2	832	789	916	354	365	637	448	590	611	734	477	220	181	555
EKR 40-2	1,016	954	1,092	399	510	823	539	834	871	918	584	242	253	799

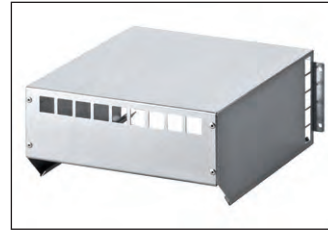
Accessorie EKR-2
Weather protection roof WSD 20-40

Article	Art. No.
WSD 20-40	0149.0083

- Weather protection roof for EKR -2 exhaust air boxes.
- The weather protection roof protects the motors of the exhaust air boxes and should be used if the EKR 2 boxes have no protection from the elements.

- The WSD 20-40 weather protection roof fits all nominal sizes of the EKR -2 exhaust air box. It is simply fitted to the exhaust air box door with four tapping screws or rivets. Four holes made in the door in the factory show the exact position.

Features

Material	Sheet steel, galvanised
Installation site	Outside wall
Width	330 mm
Height	290 mm
Depth	130 mm

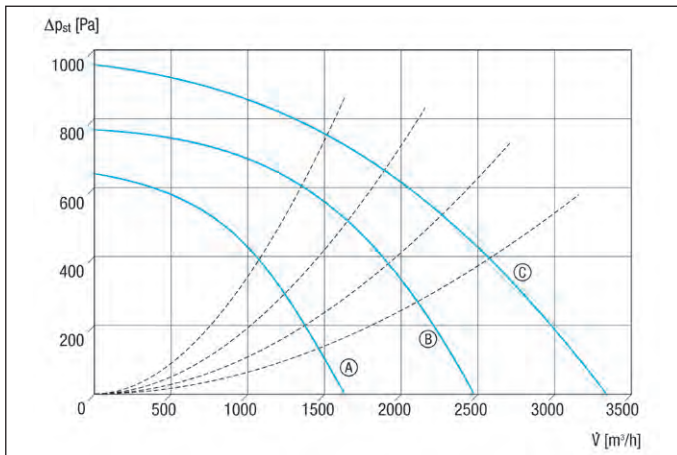
Characteristic curves for EKR 20-2, EKR 25-2 and EKR 31-2

- Ⓐ EKR 20-2
- Ⓑ EKR 25-2
- Ⓒ EKR 31-2

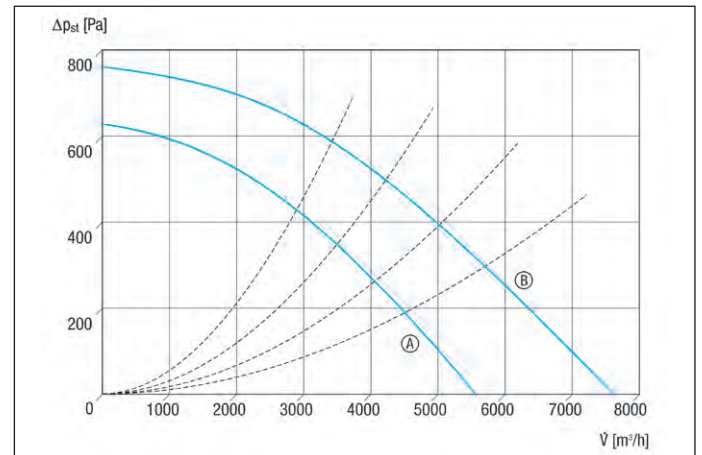
Characteristic curves for EKR 35-2 and EKR 40-2

- Ⓐ EKR 35-2
- Ⓑ EKR 40-2

Accessories selection table

	EKR 20-2	EKR 25-2	EKR 31-2	EKR 35-2	EKR 40-2	see
Specific accessories						
Weather protection roof	WSD 20-40	WSD 20-40	WSD 20-40	WSD 20-40	WSD 20-40	P. 247
General accessories						
Protective grille	SGR 20	SGR 25	SGR 31	–	–	P. 249
Tubular sound absorber	RSR 20 RSR 20/50	RSR 25 RSR 25/50	RSR 31 RSR 31/50	RSR 35/50	RSR 40/50	P. 250
Air filter	TFE 20-4 TFE 20-5 TFE 20-7	TFE 25-4 TFE 25-5 TFE 25-7	TFE 31-4 TFE 31-5 TFE 31-7	TFE 35-4 TFE 35-5 TFE 35-7	TFE 40-4 TFE 40-5 TFE 40-7	P. 250, P. 251
Motor protection switch	MVE 10	MVE 10	MVE 10	MVE 10	MVE 10	P. 336
5-step transformer	TRE 3,3-2	TRE 3,3-2	TRE 6,5-2	TRE 6,5-2	TRE 10-2	P. 340
5-step transformer, control cabinet	TRE 3,3 S-2	TRE 3,3 S-2	TRE 6,5 S-2	TRE 6,5 S-2	–	P. 341
5-step switch for TRE...S -2/ TR...S-2 5-step transformer	ESS 20	ESS 20	ESS 20	ESS 20	–	P. 341

**Mounting feet
FUR**



- Mounting feet for the assembly of ERR fans on walls, ceilings or brackets.

Dimensions [mm]

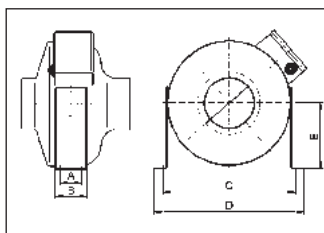

Only with FUR 35/1: With horizontal mounting stay

Article	Art. No.	Nominal size mm
FUR 10/12/16	0036.0087	100/125/160
FUR 16S/20/25	0036.0088	160/200/250
FUR 31/1	0036.0089	315
FUR 35/1	0036.0090	350

Article	A	B	C	D	E
	mm	mm	mm	mm	mm
FUR 10/12/16	30	50	280	293	125
FUR 16S/20/25	56	80	372	395	185
FUR 31/1	100	130	445	465	225
FUR 35/1	100	150	533	554	265

Common features

Material	Sheet steel, galvanised
Installation site	Wall/Ceiling

**Fixing cuffs
ELR**



- Fixing cuffs for sound and vibration dampening of duct fans.
- With 10 mm thick neoprene coating.

Dimensions [mm]

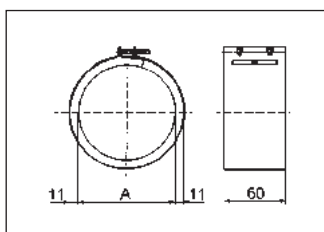

Article	Art. No.	Nominal size mm
ELR 10	0092.0109	100
ELR 12	0092.0110	120
ELR 16	0092.0111	160
ELR 20	0092.0112	200
ELR 25	0092.0113	250
ELR 31	0092.0114	315
ELR 35	0092.0115	350
ELR 40	0092.0116	400

Article	A
	mm
ELR 10	100
ELR 12	125
ELR 16	160
ELR 20	200
ELR 25	250
ELR 31	315
ELR 35	355
ELR 40	400

Common features

Material	Sheet steel, galvanised
----------	-------------------------

**Flexible cuffs
EL**



- Flexible cuffs for sound and vibration damped assembly of duct fans.
- With 2 tightening straps.

Dimensions [mm]

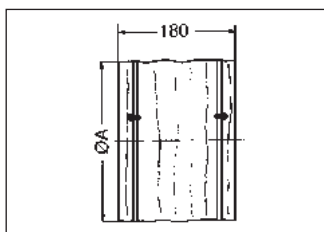

Article	Art. No.	Nominal size mm
EL 20	0092.0154	200
EL 25	0092.0088	250
EL 30	0092.0089	300
EL 35	0092.0090	350
EL 40	0092.0091	400
EL 45	0092.0155	450
EL 50	0092.0092	500
EL 56	0092.0150	560
EL 60	0092.0093	600

Article	A
	mm
EL 20	213
EL 25	263
EL 30	313
EL 35	363
EL 40	413
EL 45	458
EL 50	513
EL 56	570
EL 60	613

Common features

Material	Synthetic material
Max. ambient temperature	80 °C

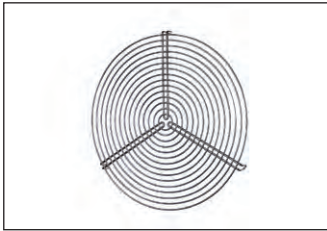
**Protective grilles
SGR**

- Protective grille for fans in accordance with DIN EN ISO 13857.
- Suitable for fans with duct connections.
- Can be fitted on the inlet or pressure side.

Dimensions [mm]

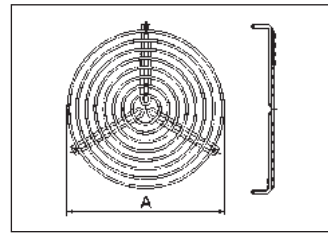

Article	Art. No.	Nominal size mm
SGR 10	0150.0123	100
SGR 12	0150.0124	125
SGR 16	0150.0125	160
SGR 20	0150.0126	200
SGR 25	0150.0127	250
SGR 31	0150.0128	315

Article	A mm
SGR 10	100
SGR 12	125
SGR 16	160
SGR 20	200
SGR 25	250
SGR 31	315

Common features

Material	Wire, chromated
Air direction	Ventilation and air extraction

**Automatic backflow
prevents
AVM**

- Horizontal and vertical mounting is possible. Air flow direction for a vertical installation is from the bottom flowing upwards.
- With 2 opposing shutter sections made of aluminium.
- With wrap-around seal.
- The backflow preventers are opened in the air flow and closed by spring force.

Dimensions [mm]

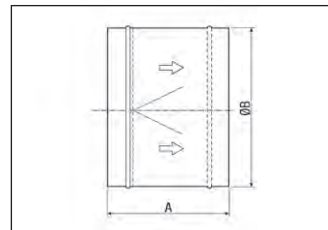

Article	Art. No.	Nominal size mm
AVM 10	0093.0002	100
AVM 12	0093.0003	125
AVM 15	0093.0004	150
AVM 16	0093.0008	160
AVM 20	0093.0006	200
AVM 25	0093.0007	250
AVM 31	0093.0009	315
AVM 35	0093.0012	355
AVM 40	0093.0013	400

Article	A mm	B mm
AVM 10	88	98
AVM 12	88	124
AVM 15	88	149
AVM 16	88	158
AVM 20	88	198
AVM 25	128	248
AVM 31	128	313
AVM 35	198	353
AVM 40	198	398

Common features

Material	Sheet steel, galvanised
Air direction	Ventilation or air extraction
Type of shutter	Airstream-operated opening/closing

Pressure losses

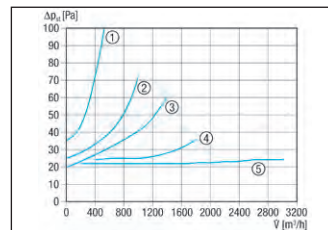

- ① AVM 10
- ② AVM 12
- ③ AVM 15
- ④ AVM 16
- ⑤ AVM 20, AVM 25, AVM 31, AVM 35, AVM 40

Accessories



**Tubular sound absorbers
RSR**



- Tubular sound absorber for ventilation systems.
- With sound absorbing cover made from fibre glass bound with artificial resin.
- Non-combustible in accordance with DIN 4102 class A1 (building material classification).
- Insertion loss measured in accordance with DIN 45646.
- Insertion loss in the octave band, see www.maico-fans.com.
- RSR...: With 25 mm thick sound absorbing cover.
- RSR.../50: With 50 mm thick sound absorbing cover.

Article	Art. No.	Nominal size mm
RSR 8	0092.0310	80
RSR 10	0092.0311	100
RSR 12	0092.0312	125
RSR 15	0092.0313	150
RSR 16	0092.0314	160
RSR 18	0092.0315	180
RSR 20	0092.0316	200
RSR 25	0092.0317	250
RSR 28	0092.0318	280
RSR 31	0092.0319	315
RSR 10/50	0092.0321	100
RSR 12/50	0092.0322	125
RSR 15/50	0092.0323	150
RSR 16/50	0092.0324	160
RSR 20/50	0092.0326	200
RSR 25/50	0092.0327	250
RSR 31/50	0092.0329	315
RSR 35/50	0092.0335	355
RSR 40/50	0092.0336	400

Dimensions [mm]

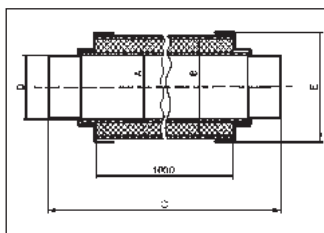

Article	A mm	B mm	C mm	D mm	E mm
RSR 8	80	125	1,120	79.5	129
RSR 10	100	150	1,120	99.5	159.5
RSR 12	125	180	1,120	124.5	189.5
RSR 15	150	200	1,120	149.5	212
RSR 16	160	200	1,120	159.5	212
RSR 18	180	224	1,120	179.5	236
RSR 20	200	250	1,120	199.5	262.5
RSR 25	250	300	1,170	249.4	312.5
RSR 28	280	355	1,170	279.5	362.5
RSR 31	315	355	1,170	314.5	367.5
RSR 10/50	100	200	1,120	99.5	212
RSR 12/50	125	224	1,120	124.5	236
RSR 15/50	150	250	1,120	149.5	262.5
RSR 16/50	160	250	1,120	159.5	262.5
RSR 20/50	200	300	1,120	199.5	312.5
RSR 25/50	250	355	1,170	249.4	362.5
RSR 31/50	315	400	1,170	314.5	413.5
RSR 35/50	355	450	1,220	354.5	463.5
RSR 40/50	400	500	1,170	399.5	513.5

Common features

Material	Aluminium
----------	-----------

**Air filters
TFE -4**



- Air filter for ventilation systems.
- Inspection lid can be removed for easy filter exchange.
- With filter insert made of synthetic fibre.
- Filter insert cannot be regenerated.
- With rubber seal on the air connection couplings.
- Accessories: Replacement air filter FE.. .
- Recommended accessories: DW 1000 differential pressure controller.

Article	Art. No.	Nominal size mm
TFE 10-4	0149.0074	100
TFE 12-4	0149.0075	125
TFE 15-4	0149.0076	150
TFE 16-4	0149.0077	160
TFE 20-4	0149.0078	200
TFE 25-4	0149.0079	250
TFE 31-4	0149.0080	315
TFE 35-4	0149.0081	355
TFE 40-4	0149.0082	400

Dimensions [mm]

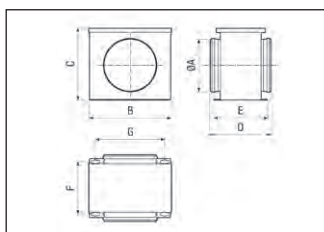

Article	A mm	B mm	C mm	D mm	E mm	F mm	G mm
TFE 10-4	100	205	165	170	142	117	150
TFE 12-4	125	210	200	190	165	138	160
TFE 15-4	150	260	230	205	178	152	210
TFE 16-4	160	260	230	205	178	152	210
TFE 20-4	200	310	275	230	222	182	260
TFE 25-4	250	365	325	325	252	227	310
TFE 31-4	315	425	390	420	352	327	370
TFE 35-4	355	505	495	550	478	457	445
TFE 40-4	400	505	495	570	478	457	445

Common features

Filter class	G4
Housing material	Sheet steel, galvanised
Max. ambient temperature	100 °C

Pressure losses

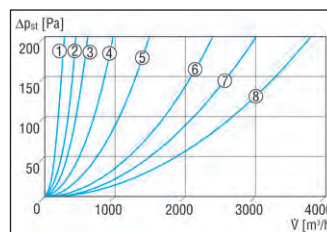

- ① TFE 10-4
- ② TFE 12-4
- ③ TFE 15-4, TFE 16-4
- ④ TFE 20-4
- ⑤ TFE 25-4
- ⑥ TFE 31-4
- ⑦ TFE 35-4
- ⑧ TFE 40-4

Air filters, replacement FE

Article	Art. No.	Nominal size mm
FE 10-1	0093.1221	100
FE 12-1	0093.1222	125
FE 15-1	0093.1223	150
FE 16-1	0093.1224	160
FE 20-1	0093.1225	200
FE 25-1	0093.1226	250
FE 31-2	0093.1227	315
FE 35-2	0093.1228	350
FE 40-2	0093.1229	400

- Replacement filter for TFE...-4 air filter.

Article	Width mm	Height mm	Depth mm
FE 10-1	220	170	10
FE 12-1	230	200	10
FE 15-1	285	230	8
FE 16-1	285	230	8
FE 20-1	340	270	8
FE 25-1	408	318	8
FE 31-2	520	390	6
FE 35-2	655	490	6
FE 40-2	670	490	10

Common features

Filter class	G4
Material	Synthetic
Max. ambient temperature	100 °C
Packing unit	2 pieces

Air filters TFE -5/TFE -7

Article	Art. No.	Nominal size mm	Filter class
TFE 10-5	0149.0058	100	F5
TFE 12-5	0149.0059	125	F5
TFE 15-5	0149.0060	150	F5
TFE 16-5	0149.0061	160	F5
TFE 20-5	0149.0062	200	F5
TFE 25-5	0149.0063	250	F5
TFE 31-5	0149.0064	315	F5
TFE 35-5	0149.0065	355	F5
TFE 40-5	0149.0066	400	F5
TFE 10-7	0149.0049	100	F7
TFE 12-7	0149.0050	125	F7
TFE 15-7	0149.0051	150	F7
TFE 16-7	0149.0052	160	F7
TFE 20-7	0149.0053	200	F7
TFE 25-7	0149.0054	250	F7
TFE 31-7	0149.0055	315	F7
TFE 35-7	0149.0056	355	F7
TFE 40-7	0149.0057	400	F7

- Air filter for ventilation systems.
- Inspection lid can be removed for easy filter exchange.
- With filter insert made of synthetic fibre.
- Panel filter.
- Filter insert cannot be regenerated.
- With rubber seal on the air connection couplings.
- TFE ...-5: Filter class F5, accessories for replacement filter RF...-5
- TFE ...-7: Filter class F7, accessories for replacement filter RF...-7
- Recommended accessories: DW 1000 differential pressure controller.

Dimensions [mm]

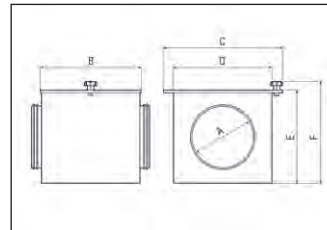

Article	A mm	B mm	C mm	D mm	E mm	F mm
TFE 10-5	100	300	360	300	300	330
TFE 12-5	125	300	360	300	300	330
TFE 15-5	150	300	360	300	300	330
TFE 16-5	160	300	360	300	300	330
TFE 20-5	200	300	360	300	300	330
TFE 25-5	250	300	360	300	300	330
TFE 31-5	315	300	460	400	500	530
TFE 35-5	355	300	460	400	500	530
TFE 40-5	400	300	560	500	500	530
TFE 10-7	100	300	360	300	300	330
TFE 12-7	125	300	360	300	300	330
TFE 15-7	150	300	360	300	300	330
TFE 16-7	160	300	360	300	300	330
TFE 20-7	200	300	360	300	300	330
TFE 25-7	250	300	360	300	300	330
TFE 31-7	315	300	460	400	500	530
TFE 35-7	355	300	460	400	500	530
TFE 40-7	400	300	560	500	500	530

Common features

Housing material	Sheet steel, galvanised
Max. ambient temperature	80 °C

Pressure losses TFE-5

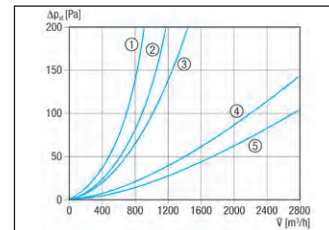

- TFE 10-5 to TFE 16-5
- TFE 20-5
- TFE 25-5
- TFE 31-5 and TFE 35-5
- TFE 40-5

Pressure losses TFE-7

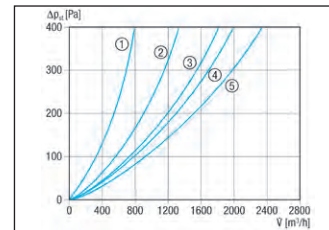

- TFE 10-7 to TFE 16-7
- TFE 20-7
- TFE 25-7
- TFE 31-7 and TFE 35-7
- TFE 40-7

Air filters, replacement RF-5/RF-7

Article	Art. No.	Nominal size in mm	Filter class
RF 10/16-5	0093.0875	100-160	F5
RF 20-5	0093.0876	200	F5
RF 25-5	0093.0877	250	F5
RF 31/35-5	0093.0878	315-355	F5
RF 40-5	0093.0879	400	F5
RF 10/16-7	0093.0880	100-160	F7
RF 20-7	0093.0881	200	F7
RF 25-7	0093.0882	250	F7
RF 31/35-7	0093.0883	315-355	F7
RF 40-7	0093.0884	400	F7

- Replacement filter for TFE air filter.
- RF ...-5: Replacement filter for TFE...-5.
- RF ...-7: Replacement filter for TFE...-7.

Article	Width mm	Height mm	Depth mm
RF 10/16-5	288	288	28
RF 20-5	288	288	50
RF 25-5	285	285	98
RF 31/35-5	495	395	50
RF 40-5	495	495	48
RF 10/16-7	290	290	28
RF 20-7	290	290	50
RF 25-7	290	290	97
RF 31/35-7	490	390	50
RF 40-7	495	495	48

Common features

Max. ambient temperature	80 °C
Packing unit	2 pieces

**Electrical air heaters
ERH/DRH**

- Electrical air heater for ventilation systems.
- With non-glowing stainless steel tubular radiators.
- Operate with ETL/DTL temperature controller (see accessories).
- Increased danger of fire if tubular radiators are dirty. Install TFE air filter as a prevention.
- Recommended accessories: FL channel sensor or FR room sensor, LW 9 air flow monitor, US 16 T contactor and TFE... air filter.

Article	Art. No.	U _{nom} V	I _{max} A	Nominal size mm	Heater power rating W
ERH 10-04	0082.0100	230	1.74	100	400
ERH 12-1	0082.0101	230	5.22	125	1,200
ERH 16-2	0082.0102	230	9.1	160	2,100
ERH 20-2	0082.0103	230	9.1	200	2,100
ERH 25-2	0082.0104	230	9.1	250	2,100
DRH 16-5	0082.0105	400	12.5	160	5,000
DRH 20-5	0082.0106	400	12.5	200	5,000
DRH 25-6	0082.0107	400	15	250	6,000
DRH 31-6	0082.0108	400	15	315	6,000

Dimensions [mm]

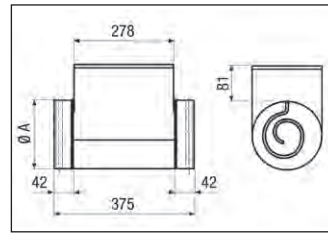

Article	A mm
ERH 10-04	100
ERH 12-1	125
ERH 16-2	160
ERH 20-2	200
ERH 25-2	250
DRH 16-5	160
DRH 20-5	200
DRH 25-6	250
DRH 31-6	315

Common features

f _{nom}	50 Hz
Degree of protection	IP 43
Housing material	Sheet steel, galvanised

Pressure losses

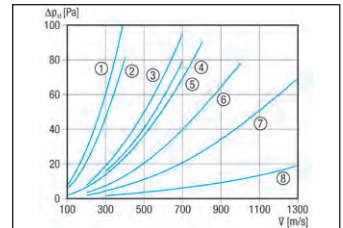

- ① DRH 16-5
- ② ERH 12-1
- ③ ERH 16-2
- ④ ERH 10-04
- ⑤ DRH 20-5
- ⑥ DRH 25-6
- ⑦ ERH 20-2
- ⑧ ERH 25-2
- ⑨ DRH 31-6

Temperature rise

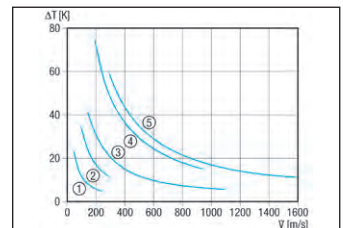

- ① ERH 10-4
- ② ERH 12-1
- ③ ERH 16-2, ERH 20-2, ERH 25-2
- ④ DRH 16-5, DRH 20-5
- ⑤ DRH 25-6, DRH 31-6

**Temperature control systems
ETL/DTL**

- Electronic temperature controller for controlling the ERH, DRH electrical air heaters.
- With integrated sensor for measuring the room temperature.
- Optional control of supply air temperature or room temperature.
- Triac regulator with pulse packet control.
- Pulse period: 60 s.
- Night reduction can be set from 0 K to 10 K below the setpoint temperature.
- DTL 16 P: With additional input for setting minimum or maximum supply air temperatures. Possible only in combination with FL 30 P channel sensor.
- Accessories: FL 30 P channel sensor for measuring the air temperature in ventilation channels; FR 30 P room sensor for measurements in enclosed areas.

Article	Art. No.	U _{nom} V
ETL 16 P	0157.0824	230
DTL 16 P	0157.0825	400

Common features

f _{nom}	50 Hz/60 Hz
Degree of protection	IP 20
Maximum load	16 A
Type of installation	Surface-mounted
Width	93 mm
Height	153 mm
Depth	40 mm

**Temperature control system
DTL 24 P**



- Electronic temperature controller for controlling the DHP electrical air heater.
- Night reduction can be set from 0 K to 4 K below the setpoint temperature.
- Triac regulator with pulse packet control.
- Control via 0 V to 10 V possible.
- To increase power up to 30 kW, use DTL 2 P-L.

Article	Art. No.
DTL 24 P	0157.0586

Features

U _{nom}	400 V
Degree of protection	IP 20
Maximum load	24 A
Type of installation	Surface-mounted
Width	200 mm
Height	290 mm
Depth	195 mm

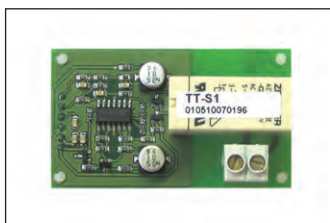
**Power board
DTL 2 P-L**



- Additional board for installation in the DTL 24 P electronic temperature control to meet a power requirement of 16.5 kW to 30 kW.

Features

U _{nom}	400 V
Width	60 mm
Height	35 mm
Depth	30 mm

Article	Art. No.
DTL 2 P-L	0157.0587

**Channel sensor
FL 30 P**



- Temperature sensor for measuring the air temperature in air channels.
- Can be combined with ETL 16 P, DTL 16 P, DTL 24 P.

Features

Degree of protection	IP 20
Material	Synthetic material
Temperature setting range	0 °C up to 30 °C
Installation site	Channel

Article	Art. No.
FL 30 P	0157.0780

**Room sensor
FR 30 P**



- Temperature sensor for measuring the air temperature in enclosed areas.
- Can be combined with ETL 16 P, DTL 16 P, DTL 24 P.

Features

Degree of protection	IP 20
Housing material	Synthetic material
Colour	Pure white, similar to RAL 9010
Temperature setting range	0 °C up to 30 °C
Type of installation	Surface-mounted
Width	86 mm
Height	86 mm
Depth	30 mm

Article	Art. No.
FR 30 P	0157.0781

**Electrical air heaters with controller
ERH R/DRH R**



- Electrical air heater for ventilation systems.
- With integrated temperature controller.
- With non-glowing stainless steel tubular radiators.
- FR 30 P room sensor and FL 30 P channel sensor included in the scope of delivery.
- Increased danger of fire if tubular radiators are dirty. Install TFE air filter as a prevention.
- Recommended accessories: LW 9 air flow monitor and TFE... air filter.

Dimensions [mm]

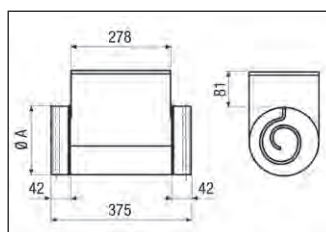

DRH 35-12 R: No rubber seal on the connection couplings

Common features

f _{nom}	50 Hz
Degree of protection	IP 43
Housing material	Sheet steel, galvanised

Pressure losses

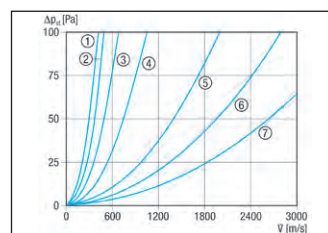

- ① ERH 16-2 R
- ② DRH 16-5 R
- ③ DRH 20-6 R
- ④ DRH 25-9 R
- ⑤ DRH 31-12 R
- ⑥ DRH 35-12 R
- ⑦ DRH 40-12 R

Article	Art. No.	U _{nom} V	I _{max} A	Nominal size mm	Heater power rating W
ERH 16-2 R	0082.0142	230	9.1	160	2,100
DRH 16-5 R	0082.0143	400	12.5	160	5,000
DRH 20-6 R	0082.0144	400	15	200	6,000
DRH 25-9 R	0082.0145	400	13	250	9,000
DRH 31-12 R	0082.0146	400	17.3	315	12,000
DRH 35-12 R	0082.0147	400	17.3	350	12,000
DRH 40-12 R	0082.0148	400	17.3	400	12,000

Article	A mm
ERH 16-2 R	160
DRH 16-5 R	160
DRH 20-6 R	200
DRH 25-9 R	250
DRH 31-12 R	315
DRH 35-12 R	350
DRH 40-12 R	400

**Water air heaters
WRH**

- Water air heater for ventilation systems.
- Connections made of copper.
- Housing cover can be removed for service work.
- With rubber seal on the air connection couplings.

Article	Art. No.	Nominal size mm	Heater power rating W	Open cross section cm ²
WRH 10-1	0082.0116	100	1,300	1,012
WRH 12-1	0082.0117	125	1,700	1,215
WRH 16-2	0082.0118	160	3,800	1,458
WRH 20-2	0082.0119	200	5,000	1,701
WRH 25-4	0082.0120	250	8,300	2,268
WRH 31-6	0082.0121	315	13,100	3,240
WRH 40-9	0082.0122	400	20,600	4,050

Dimensions [mm]

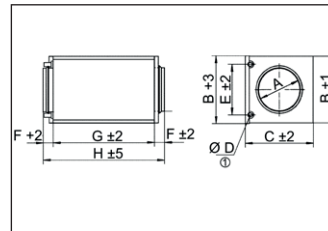

ⓐ External connection diameter

Article	A	B	C	D	E	F	G	H
	mm	mm	mm	mm	mm	mm	mm	mm
WRH 10-1	100	183	225	10	137	40	300	380
WRH 12-1	125	183	225	10	137	40	300	380
WRH 16-2	160	258	305	10	212	40	300	380
WRH 20-2	200	258	305	10	212	40	300	380
WRH 25-4	250	333	385	22	250	40	300	380
WRH 31-6	315	408	460	22	325	40	300	380
WRH 40-9	400	483	540	22	400	70	300	440

Common features

Housing material	Sheet steel, galvanised
Inlet temperature	70 °C
Return flow temperature	50 °C
Max. water temperature	100 °C
Max. water pressure	6 bar

Pressure losses

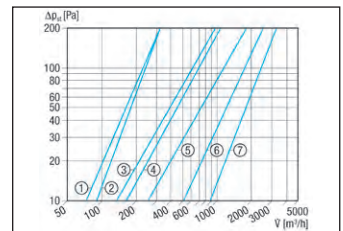

- ① WRH 10-1
- ② WRH 12-1
- ③ WRH 16-2
- ④ WRH 20-2
- ⑤ WRH 25-4
- ⑥ WRH 31-6
- ⑦ WRH 40-9

Temperature rise

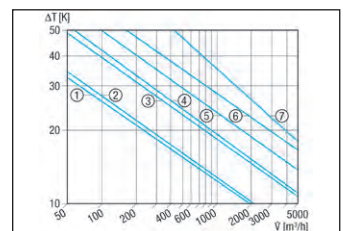

- ① WRH 10-1
- ② WRH 12-1
- ③ WRH 16-2
- ④ WRH 20-2
- ⑤ WRH 25-4
- ⑥ WRH 31-6
- ⑦ WRH 40-9

**Room air control
RLS 3**

- Three-step room air control for ER 100 D exhaust air fan, ZEG 2000 P exhaust air unit, WS 150 centralised ventilation unit and HDR EC duct fan.
- 3 switching steps: Base load, Normal, Full-load (rotary knob).
- With separate, 2-pole on/off switch (rocker switch).
- Both switches in joint double frame.

Article	Art. No.
RLS 3	0157.0831

Features

U _{nom}	230 V
Degree of protection	IP 30
Maximum load	10 A
Material	Synthetic material
Type of installation	Recessed-mounted
Width	150 mm
Height	80 mm
Depth	32 mm

Channel fans

Example illustration of a ventilation installation

- Our response to your requirements is channel ventilation systems from MAICO. After all, these systems are suited to numerous applications:
 - Production areas
 - Machine extraction units
 - Industrial buildings
- As a rule, channel ventilation systems are used wherever large volumes of air need displacing. MAICO's range includes fans and components for channel dimensions of between 500 x 250 mm and 1,000 x 500 mm.
- It doesn't matter which MAICO channel ventilation system you work with: Their benefit lies in the modular system. Since all the components fit regardless of the sizes or product groups involved.
- MAICO also offers an extensive range of accessories:
 - Sound absorber
 - Electric-air or water air heater
 - Air filter
 - Shutters and grilles for inside and outside

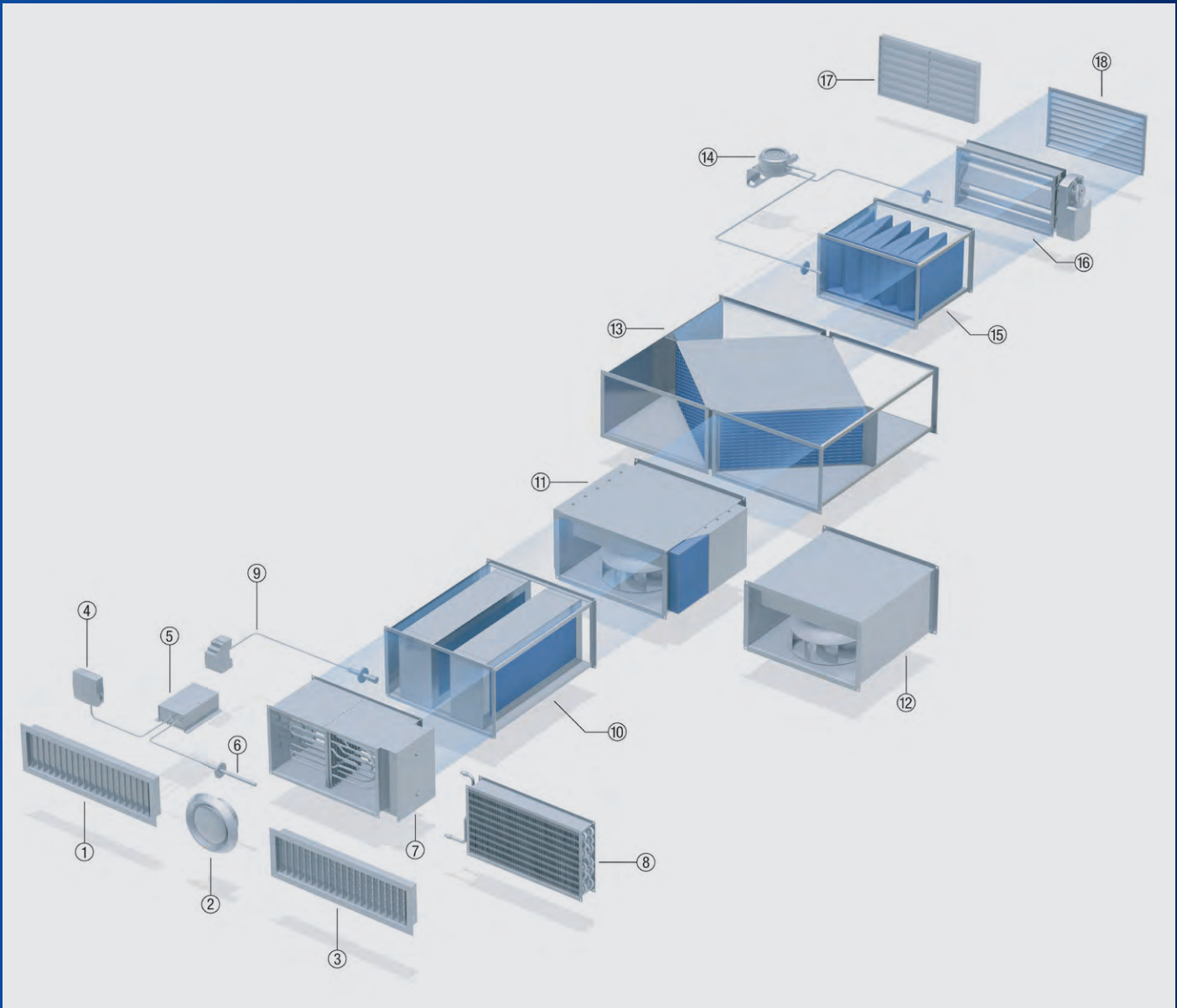

- ① Exhaust air grill
- ② Disk valve
- ③ Supply air grille
- ④ Room sensor
- ⑤ Temperature controller
- ⑥ Channel sensor
- ⑦ Water air heater
- ⑧ Electrical air heater
- ⑨ Air flow monitor
- ⑩ Channel sound absorber
- ⑪ Centrifugal channel fan DPK EC
- ⑫ Sound-insulated centrifual
- ⑬ channel fan DSK EC
- ⑭ Heat exchanger (to be provided on site)
- ⑮ Air filter
- ⑯ Differential pressure controller
- ⑰ Electrical shutter
- ⑱ Airstream-operated shutter
- ⑲ External grille

DPK EC channel fan

With EC technology
up to 11,700 m³/h



Page 258

DSK EC sound-insulated channel fan

Sound-insulated, with swivelling fan
and EC technology, up to 11,700 m³/h



Page 260

Accessories

Flexible couplings, shutters, external grilles, sound insulation, air filters, air heaters, etc.



Page 262



Features

- Installation in rectangular ventilation channels.
- Galvanised housing.
- Low energy consumption thanks to EC technology.
- Reduced space requirement due to compact dimensions.

- Flange profiles fitted on the inlet and outlet sides.
- Centrifugal impeller made of galvanised steel, with backwards curved blades.
- Directly driven impeller located on the motor shaft.
- Statically and dynamically balanced in accordance with DIN ISO 1940, balance quality 6.3.
- Motor impeller can be swivelled out for cleaning purposes.
- High degree of protection IP 54.
- Use ELP flexible coupling to prevent transmission of vibrations onto the channel system.

Air flow direction

- Airstream and rotational direction are marked by arrows on the fan housing.
- Clockwise direction of rotation viewed from the intake side.

Motor

- Motor designed for continuous operation.
- Robust motor with ball bearings, maintenance-free.
- Thermal motor protection as standard feature.
- Integrated motor protection routed via alarm relay.
- Speed can be specified in continuously variable manner in control mode using a 0 - 10 V signal or potentiometer.

Electrical connection

- Depending on model, is connected at terminal box or led-out cable.
- 50 Hz power frequency.

Mounting instructions

- Can be fitted in any position.

Technical data

Article	Art. No.	U _{nom} V	f _{nom} Hz	Air flow volume m ³ /h	Rotating speed 1/min	P _{nom} W	I _{nom} A	T _{max} °C	Sound power level L _{WAS} dB(A)	Insulation class	Weight kg
500 x 250											
DPK 22 EC	0086.0800	230	50	2,000	1,650	198	1.2	50	69	F	20.1
600 x 350											
DPK 31 EC	0086.0802	230	50	3,500	1,500	349	2	50	72	F	31.8
600 x 350											
DPK 31-S EC	0086.0804	400	50	4,900	1,700	677	1.3	50	77	F	37
700 x 400											
DPK 35 EC	0086.0806	400	50	6,400	1,700	1,260	2.2	50	80	F	47.5
800 x 500											
DPK 50 EC	0086.0808	400	50	9,800	1,500	1,950	2.8	50	82	F	68
1,000 x 500											
DPK 56 EC	0086.0810	400	50	11,700	1,400	2,530	3.9	50	84	F	89

Dimensions [mm]

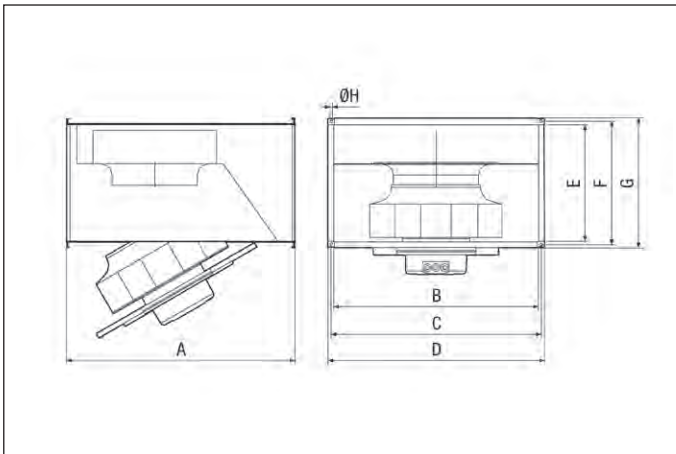

Article	A	B	C	D	E	F	G	H
DPK 22 EC	530	500	520	540	250	270	290	9
DPK 31 EC	700	600	620	640	350	370	390	9
DPK 31-S EC	700	600	620	640	350	370	390	9
DPK 35 EC	780	700	720	740	400	420	440	9
DPK 50 EC	880	800	820	840	500	520	540	9
DPK 56 EC	982	1,000	1,020	1,040	500	520	540	9

Characteristic curves for channel dimension
500 x 250 mm and 600 x 350 mm

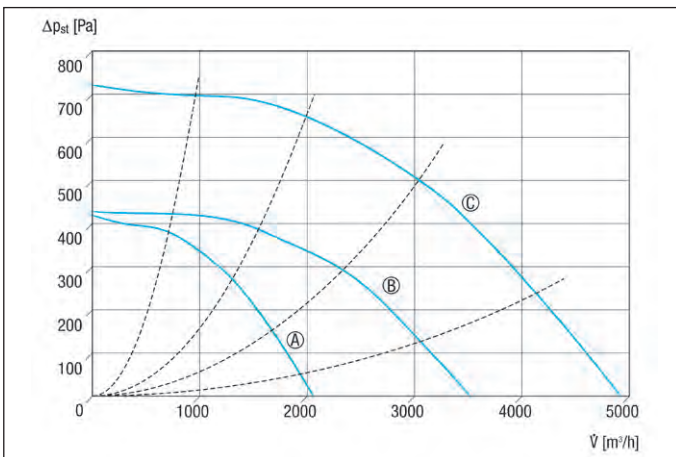

Ⓐ DPK 22 EC
Ⓑ DPK 31 EC
Ⓒ DPK 31-S EC

Characteristic curves for channel dimension
700 x 400 mm, 800 x 500 mm and 1000 x 500 mm

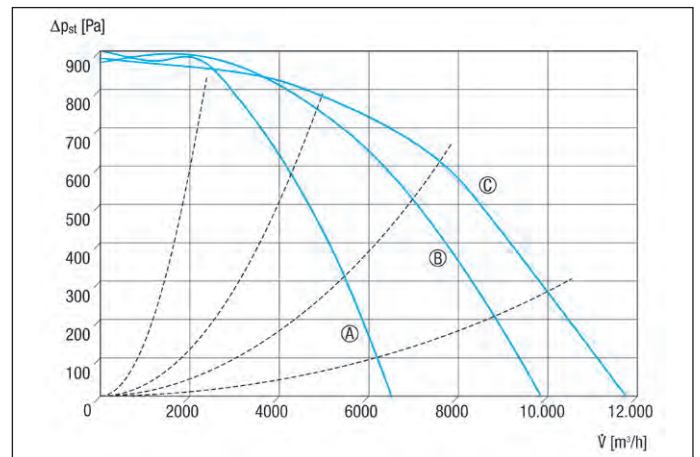

Ⓐ DPK 35 EC
Ⓑ DPK 50 EC
Ⓒ DPK 56 EC

Accessories selection table

	DPK 22 EC	DPK 31 EC	DPK 31-S EC	DPK 35 EC	DPK 50 EC	DPK 56 EC	see
General accessories							
Channel shutter	AKP 22 RKP 22	AKP 31 RKP 31	AKP 31 RKP 31	AKP 35 RKP 35	RKP 50	RKP 56	P. 262 P. 263
Servomotor	MS 8 MS 8 P	MS 8 MS 8 P	MS 8 MS 8 P	MS 8 MS 8 P	MS 8 MS 8 P	MS 8 MS 8 P	P. 263
External grille	LZP 22	LZP 31	LZP 31	LZP 35	LZP 50	LZP 56	P. 264
Flexible coupling	ELP 22	ELP 31	ELP 31	ELP 35	ELP 50	ELP 56	P. 262
Channel sound absorber	KSP 22/15 KSP 22/27	KSP 31/14 KSP 31/27	KSP 31/14 KSP 31/27	KSP 35/14 KSP 35/23	KSP 50/23	KSP 56/25	P. 264
Electrical air heater	DHP 22-9 DHP 22-16	DHP 31-16 DHP 31-28	DHP 31-16	–	–	–	P. 266
Water air heater	WHP 22-18	WHP 31-34	WHP 31-34	WHP 35-43	WHP 50-55	WHP 56-69	P. 269
Air filter	TFP 22 TFP 22-7	TFP 31 TFP 31-7	TFP 31 TFP 31-7	TFP 35 TFP 35-7	TFP 50 TFP 50-7	TFP 56 TFP 56-7	P. 265
Potentiometer	ST EC 010 ST EC 230 ST EC 3	ST EC 010 ST EC 230 ST EC 3	ST EC 010 ST EC 230 ST EC 3	ST EC 010 ST EC 230 ST EC 3	ST EC 010 ST EC 230 ST EC 3	ST EC 010 ST EC 230 ST EC 3	P. 337
Pressure and temperature control system	EAT EC	EAT EC	EAT EC	EAT EC	EAT EC	EAT EC	P. 345

DSK EC sound-insulated channel fan



- Low energy consumption thanks to EC technology.
- Reduced space requirement due to compact dimensions.
- Flange profiles fitted on the inlet and outlet sides.
- Centrifugal impeller with backwards curved blades.
- Statically and dynamically balanced in accordance with DIN ISO 1940, balance quality 6.3.
- High degree of protection IP 54.
- Use ELP flexible coupling to prevent transmission of vibrations onto the channel system.

Motor

- Motor designed for continuous operation.
- Robust motor with ball bearings, maintenance-free.
- Speed can be specified in continuously variable manner in control mode using a 0 - 10 V signal or potentiometer.
- Integrated thermal motor protection.

Mounting instructions

- Can be fitted in any position.

Electrical connection

- Depending on model, is connected at terminal box or led-out cable.
- 50 Hz power frequency.

Air flow direction

- Airstream and rotational direction are marked by arrows on the fan housing.
- Clockwise direction of rotation viewed from the intake side.

Features

- Installation in rectangular ventilation channels.
- With sound absorbing lining to meet the increased requirements for especially low noise levels.

Technical data

Article	Art. No.	U _{nom}	f _{nom}	Air flow volume	Rotating speed	P _{nom}	I _{nom}	T _{max}	Sound power level	Insulation class	Weight
		V	Hz	m ³ /h	1/min	W	A	°C	L _{WAS} dB(A)		kg
500 x 250											
DSK 22 EC	0086.0801	230	50	2,000	1,650	198	1.2	50	65	F	24.5
600 x 350											
DSK 31 EC	0086.0803	230	50	3,500	1,500	349	2	50	68	F	38.5
600 x 350											
DSK 31-S EC	0086.0805	400	50	4,900	1,700	677	1.3	50	70	F	44
700 x 400											
DSK 35 EC	0086.0807	400	50	6,400	1,700	1,260	2.2	50	74	F	56.5
800 x 500											
DSK 50 EC	0086.0809	400	50	9,800	1,500	1,950	2.8	40	75	F	82.5
1,000 x 500											
DSK 56 EC	0086.0811	400	50	11,700	1,400	2,530	3.9	50	75	F	104

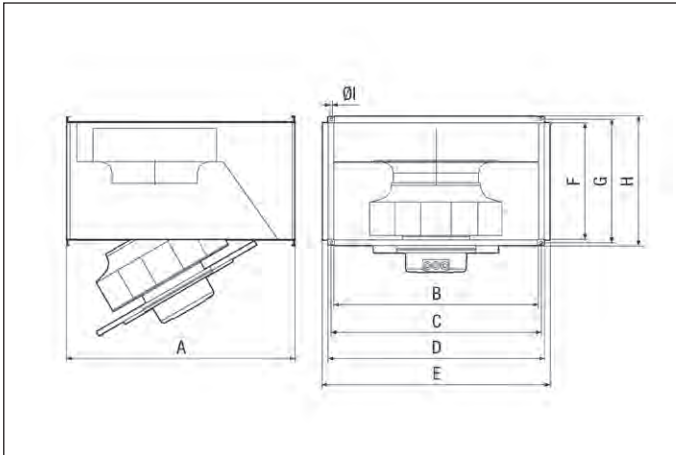

Dimensions [mm]

Article	A	B	C	D	E	F	G	H	I
DSK 22 EC	530	500	520	540	580	250	270	290	9
DSK 31 EC	700	600	620	640	680	350	370	390	9
DSK 31-S EC	700	600	620	640	680	350	370	390	9
DSK 35 EC	780	700	720	740	780	400	420	440	9
DSK 50 EC	880	800	820	840	880	500	520	540	9
DSK 56 EC	982	1,000	1,020	1,040	1,080	500	520	540	9

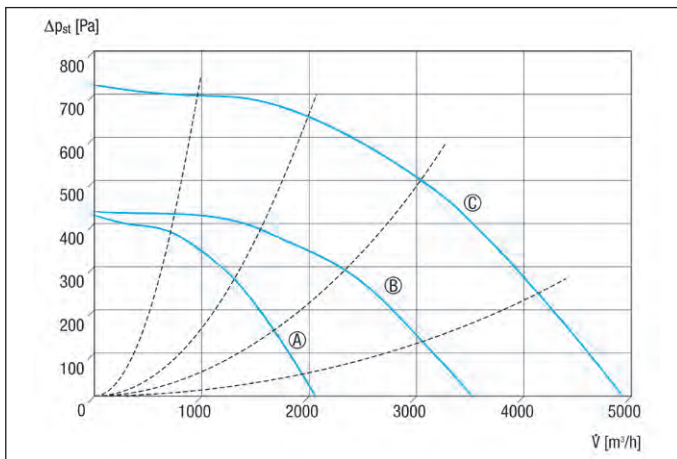
**Characteristic curves for channel dimension
500 x 250 mm and 600 x 350 mm**

Ⓐ DSK 22 EC
Ⓑ DSK 31 EC
Ⓒ DSK 31-S EC

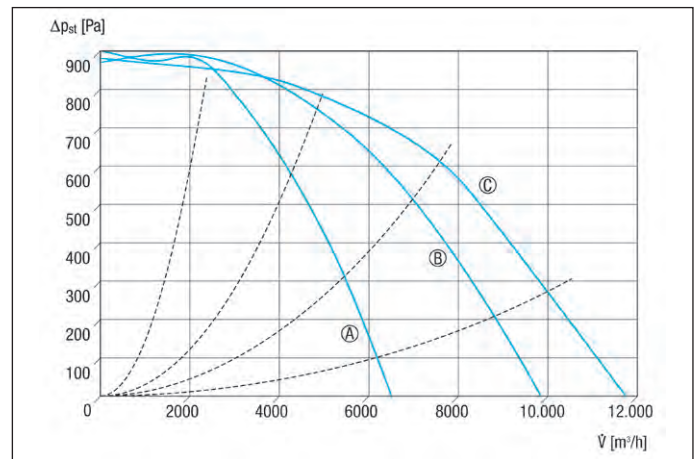
**Characteristic curves for channel dimension
700 x 400 mm, 800 x 500 mm and 1000 x 500 mm**

Ⓐ DSK 35 EC
Ⓑ DSK 50 EC
Ⓒ DSK 56 EC

Accessories selection table

	DSK 22 EC	DSK 31 EC	DSK 31-S EC	DSK 35 EC	DSK 50 EC	DSK 56 EC	see
General accessories							
Channel shutter	AKP 22 RKP 22	AKP 31 RKP 31	AKP 31 RKP 31	AKP 35 RKP 35	RKP 50	RKP 56	P. 262 P. 263
Servomotor	MS 8 MS 8 P	MS 8 MS 8 P	MS 8 MS 8 P	MS 8 MS 8 P	MS 8 MS 8 P	MS 8 MS 8 P	P. 263
External grille	LZP 22	LZP 31	LZP 31	LZP 35	LZP 50	LZP 56	P. 264
Flexible coupling	ELP 22	ELP 31	ELP 31	ELP 35	ELP 50	ELP 56	P. 262
Channel sound absorber	KSP 22/15 KSP 22/27	KSP 31/14 KSP 31/27	KSP 31/14 KSP 31/27	KSP 35/14 KSP 35/23	KSP 50/23	KSP 56/25	P. 264
Electrical air heater	DHP 22-9 DHP 22-16	DHP 31-16 DHP 31-28	DHP 31-16 DHP 31-28	–	–	–	P. 266
Water air heater	WHP 22-18	WHP 31-34	WHP 31-34	WHP 35-43	WHP 50-55	WHP 56-69	P. 269
Air filter	TFP 22 TFP 22-7	TFP 31 TFP 31-7	TFP 31 TFP 31-7	TFP 35 TFP 35-7	TFP 50 TFP 50-7	TFP 56 TFP 56-7	P. 265
Potentiometer	ST EC 010 ST EC 230 ST EC 3	ST EC 010 ST EC 230 ST EC 3	ST EC 010 ST EC 230 ST EC 3	ST EC 010 ST EC 230 ST EC 3	ST EC 010 ST EC 230 ST EC 3	ST EC 010 ST EC 230 ST EC 3	P. 337
Pressure and temperature control system	EAT EC	EAT EC	EAT EC	EAT EC	EAT EC	EAT EC	P. 345

**Flexible couplings
ELP**



- Flexible couplings for mounting channel fans that are free from structure-borne noise.
- With square flange connection frames made of galvanised steel.
- Installation on the inlet and outlet sides.

Dimensions [mm]

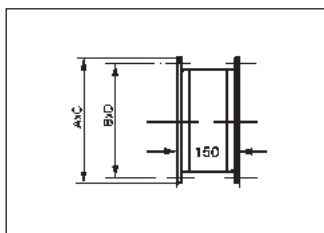

Common features

Material	Synthetic material
Installation site	Channel

Article	Art. No.	Channel width dimension mm	Channel height dimension mm
ELP 22	0092.0125	500	250
ELP 25	0092.0126	500	300
ELP 28	0092.0127	600	300
ELP 31	0092.0128	600	350
ELP 35	0092.0129	700	400
ELP 50	0092.0123	800	500
ELP 56	0092.0124	1,000	500
ELP 93	0092.0263	900	300
ELP 94	0092.0264	900	400

Article	A mm	B mm	C mm	D mm
ELP 22	290	270	540	520
ELP 25	340	320	540	520
ELP 28	340	320	640	620
ELP 31	390	370	640	620
ELP 35	440	420	740	720
ELP 50	540	520	840	820
ELP 56	540	520	1,040	1,020
ELP 93	340	320	940	920
ELP 94	440	420	940	920

**Channel shutters
AKP**

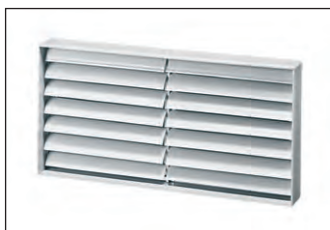

- Shutters for air extraction.
- With galvanised protective grille.

Dimensions [mm]

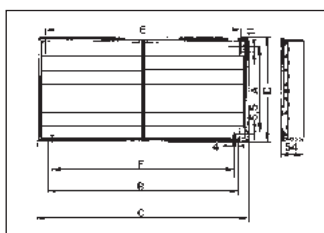

Common features

Loss of pressure	10 Pa
Material	Synthetic material, weather and UV resistant
Colour	Light grey
Installation site	Channel
Max. ambient temperature	60 °C
Air direction	Air extraction
Type of shutter	Airstream-operated opening/closing

Article	Art. No.	Channel width dimension mm	Channel height dimension mm
AKP 22	0151.0096	500	250
AKP 25	0151.0097	500	300
AKP 28	0151.0098	600	300
AKP 31	0151.0099	600	350
AKP 35	0151.0100	700	400

Article	A mm	B mm	C mm	D mm	E mm	F mm
AKP 22	290	540	585	335	551	517
AKP 25	340	540	585	385	551	517
AKP 28	340	640	685	385	651	617
AKP 31	390	640	685	435	651	617
AKP 35	440	740	785	485	751	717

Channel shutters RKP



- With counter-rotating, hollow body lamella, which can be adjusted together over 15 x 15 mm square.
- With U-shaped frame and flange holes on both sides.
- With position indicator - Open/ Closed.
- Must be combined with additional MS 8 or MS 8 P servomotors (servomotor is not included in the delivery).

Article	Art. No.	Channel width dimension mm	Channel height dimension mm
RKP 22	0151.0235	500	250
RKP 25	0151.0236	500	300
RKP 28	0151.0237	600	300
RKP 31	0151.0238	600	350
RKP 35	0151.0239	700	400
RKP 50	0151.0240	800	500
RKP 56	0151.0241	1,000	500

Dimensions [mm]

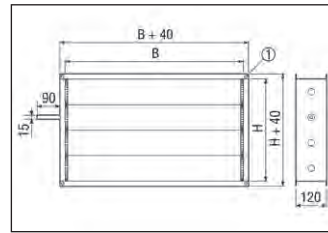

⊙ Slot, 9 x 12 mm

Article	B mm	H mm
RKP 22	500	250
RKP 25	500	300
RKP 28	600	300
RKP 31	600	350
RKP 35	700	400
RKP 50	800	500
RKP 56	1,000	500

Pressure losses

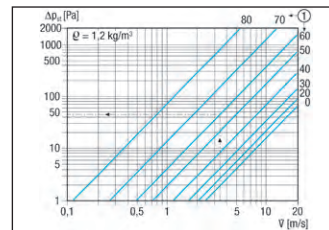

⊙ Angle of lamella in degrees

Common features

Material	Sheet steel, galvanised
Installation site	Channel
Air direction	Ventilation and air extraction
Type of shutter	electrical

Servo motors MS 8



Article	Art. No.
MS 8	0157.0760
MS 8 P	0157.0761

- Servomotors for opening and closing the RKP duct shutter and JRE blind control shutter.
- With limiting strap for torsion safety.
- Can be combined with drive axis up to 20 mm diameter or 16 mm square.
- Maximum turning angle: 90°.
- Turning angle limit adjustable in 5° steps.
- With two-point control for "Open" and "Closed" settings.
- Drive axis can be rotated to the right or left.
- MS 8 P: With 2 additional auxiliary switches.
- Not suitable for use in areas subject to explosion hazards.

Installation instruction

- With pushbutton for release of the gear, e.g. for manual setting of the shutter.
- If PG 11 screws are used: IP 54 degree of protection.
- Note: US 16 T universal contactor or customer-provided relay required for speed control with phase angles.
- 4-core mains cable is needed.

Common features

U _{nom}	230 V
f _{nom}	50 Hz/60 Hz
Degree of protection	IP 44
Maximum load (inductive load)	2 A
Maximum load (ohmic load)	10 A
Housing material	Synthetic material, weather and UV resistant
Colour	Blue
Width	100 mm
Height	180 mm
Depth	65 mm

**External grilles
LZP**



- External grille for air extraction and ventilation.
- With fixed rain-repellent weather protection lamella.
- With frame for mounting in masonry walls.
- Protective grille in accordance with DIN EN ISO 13857.

Dimensions [mm]

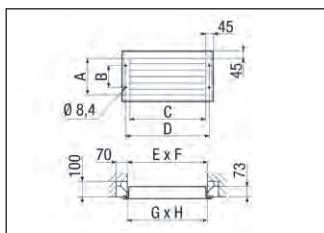

Common features

Material	Sheet steel, galvanised
Installation site	Wall/Channel
Air direction	Ventilation and air extraction

Article	Art. No.	Channel width dimension mm	Channel height dimension mm
LZP 22	0151.0255	500	250
LZP 25	0151.0256	500	300
LZP 28	0151.0257	600	300
LZP 31	0151.0258	600	350
LZP 35	0151.0259	700	400
LZP 50	0151.0314	800	500
LZP 56	0151.0315	1,000	500

Article	A	B	C	D	E	F	G	H
	mm	mm	mm	mm	mm	mm	mm	mm
LZP 22	235	125	485	529	510	260	500	250
LZP 25	285	175	485	529	510	310	500	300
LZP 28	285	175	585	629	610	310	600	300
LZP 31	335	225	585	629	610	360	600	350
LZP 35	385	275	685	729	710	410	700	400
LZP 50	485	375	785	829	810	510	800	500
LZP 56	485	375	985	1,029	1,010	510	1,000	500

Pressure losses

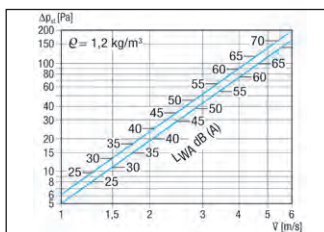

**Channel sound absorbers
KSP**



- Silencer for ventilation systems.
- With silencing elements made from non-abrasive mineral fibre plates, with airtight folded-seam connections covered by galvanised sheet steel.
- Flanges on both sides for installation in square ventilation channels.
- Non-combustible in accordance with DIN 4102.
- KSP ../23 and KSP ../27: With a cover of glass silk fabrics around the silencing elements.
- KSP ../23 and KSP ../27: Adaptors (to be supplied by the customer) are required (see channel dimension A x B).

Dimensions [mm]

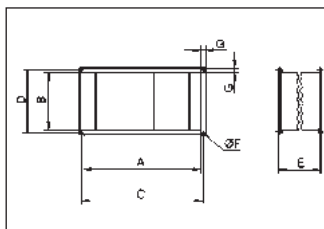

Common features

Housing material	Sheet steel, galvanised
Max. flow velocity	20 m/s
Installation site	Channel

Article	Art. No.	Channel width dimension mm	Channel height dimension mm
KSP 22/15	0092.0301	500	250
KSP 25/15	0092.0302	500	300
KSP 28/14	0092.0303	600	300
KSP 31/14	0092.0304	600	350
KSP 35/14	0092.0305	700	400
KSP 22/27	0092.0330	600	250
KSP 25/27	0092.0331	600	300
KSP 28/23	0092.0332	700	300
KSP 31/27	0092.0333	1,000	350
KSP 35/23	0092.0334	1,000	400
KSP 50/23	0092.0306	1,000	500
KSP 56/25	0092.0307	1,350	500
KSP 93/28	0092.0504	900	300
KSP 94/28	0092.0505	900	400

Article	A	B	C	D	E	F	G
	mm	mm	mm	mm	mm	mm	mm
KSP 22/15	500	250	520	270	900	9	20
KSP 25/15	500	300	520	320	900	9	20
KSP 28/14	600	300	620	320	600	9	20
KSP 31/14	600	350	620	370	600	9	20
KSP 35/14	700	400	720	420	600	9	20
KSP 22/27	600	250	620	270	1,250	12	20
KSP 25/27	600	300	620	320	1,250	12	20
KSP 28/23	700	300	720	320	1,500	12	20
KSP 31/27	1,000	350	1,020	370	1,250	12	20
KSP 35/23	1,000	400	1,020	420	1,500	12	20
KSP 50/23	1,000	500	1,020	520	1,500	12	20
KSP 56/25	1,350	500	1,370	520	1,500	12	20
KSP 93/28	900	300	920	320	1,250	9	20
KSP 94/28	900	400	920	420	1,250	9	20

Air filters
TFP



- Air filter for ventilation systems.
- Flanges on both sides for installation in square ventilation channels.
- Inspection lid can be removed for easy filter exchange.
- Accessories: KF.. replacement air filter and DW 1000 differential pressure controller.

Article	Art. No.	Chan- nel width dimen- sion mm	Chan- nel height dimen- sion mm	Filter nel class
TFP 22	0149.0031	500	250	G4
TFP 25	0149.0032	500	300	G4
TFP 28	0149.0033	600	300	G4
TFP 31	0149.0034	600	350	G4
TFP 35	0149.0035	700	400	G4
TFP 50	0149.0036	800	500	G4
TFP 56	0149.0037	1,000	500	G4
TFP 22-7	0149.0067	500	250	F7
TFP 25-7	0149.0068	500	300	F7
TFP 28-7	0149.0069	600	300	F7
TFP 31-7	0149.0070	600	350	F7
TFP 35-7	0149.0071	700	400	F7
TFP 50-7	0149.0072	800	500	F7
TFP 56-7	0149.0073	1,000	500	F7

Dimensions [mm]

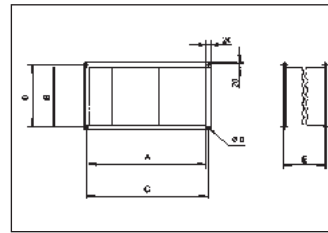

Article	A	B	C	D	E
	mm	mm	mm	mm	mm
TFP 22	500	250	520	270	500
TFP 25	500	300	520	320	500
TFP 28	600	300	620	320	550
TFP 31	600	350	620	370	600
TFP 35	700	400	720	420	600
TFP 50	800	500	820	520	700
TFP 56	1,000	500	1,020	520	700
TFP 22-7	500	250	520	270	500
TFP 25-7	500	300	520	320	500
TFP 28-7	600	300	620	320	550
TFP 31-7	600	350	620	370	600
TFP 35-7	700	400	720	420	600
TFP 50-7	800	500	820	520	700
TFP 56-7	1,000	500	1,020	520	700

Common features

Housing material	Sheet steel, galvanised
Installation site	Channel

Pressure losses TFP

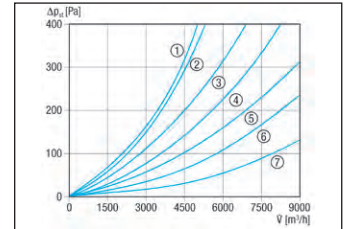

- ① TFP 22
- ② TFP 25
- ③ TFP 28
- ④ TFP 31
- ⑤ TFP 35
- ⑥ TFP 50
- ⑦ TFP 56

Pressure losses TFP-7

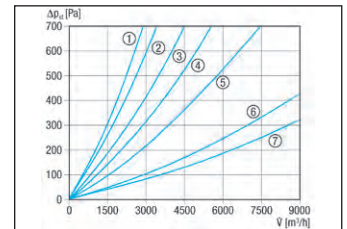

- ① TFP 22-7
- ② TFP 25-7
- ③ TFP 28-7
- ④ TFP 31-7
- ⑤ TFP 35-7
- ⑥ TFP 50-7
- ⑦ TFP 56-7

Air filters, replacement
KF

Article	Art. No.	Chan- nel width dimen- sion mm	Chan- nel height dimen- sion mm	Filter nel class
KF 22	0093.0681	500	250	G4
KF 25	0093.0682	500	300	G4
KF 28	0093.0683	600	300	G4
KF 31	0093.0684	600	350	G4
KF 35	0093.0685	700	400	G4
KF 50	0093.0686	800	500	G4
KF 56	0093.0687	1,000	500	G4
KF 22-7	0093.0863	500	250	F7
KF 25-7	0093.0864	500	300	F7
KF 28-7	0093.0865	600	300	F7
KF 31-7	0093.0866	600	350	F7
KF 35-7	0093.0867	700	400	F7
KF 50-7	0093.0868	800	500	F7
KF 56-7	0093.0869	1,000	500	F7

- Replacement filter for TFP and TFP -7.
- Pocket filter.

Common features

Max. ambient temperature	70 °C
Packing unit	2 pieces

**Temperature control system
DTL 24 P**



Article **Art. No.**
DTL 24 P 0157.0586

- Electronic temperature controller for controlling the DHP electrical air heater.
- Night reduction can be set from 0 K to 4 K below the setpoint temperature.
- Triac regulator with pulse packet control.
- Control via 0 V to 10 V possible.
- To increase power up to 30 kW, use DTL 2 P-L.

Features

U _{nom}	400 V
Degree of protection	IP 20
Maximum load	24 A
Type of installation	Surface-mounted
Width	200 mm
Height	290 mm
Depth	195 mm

**Power board
DTL 2 P-L**



Article **Art. No.**
DTL 2 P-L 0157.0587

- Additional board for installation in the DTL 24 P electronic temperature control to meet a power requirement of 16.5 kW to 30 kW.

Features

U _{nom}	400 V
Width	60 mm
Height	35 mm
Depth	30 mm

**Channel sensor
FL 30 P**



Article **Art. No.**
FL 30 P 0157.0780

- Temperature sensor for measuring the air temperature in air channels.
- Can be combined with ETL 16 P, DTL 16 P, DTL 24 P.

Features

Degree of protection	IP 20
Material	Synthetic material
Temperature setting range	0 °C up to 30 °C
Installation site	Channel

**Room sensor
FR 30 P**



Article **Art. No.**
FR 30 P 0157.0781

- Temperature sensor for measuring the air temperature in enclosed areas.
- Can be combined with ETL 16 P, DTL 16 P, DTL 24 P.

Features

Degree of protection	IP 20
Housing material	Synthetic material
Colour	Pure white, similar to RAL 9010
Temperature setting range	0 °C up to 30 °C
Type of installation	Surface-mounted
Width	86 mm
Height	86 mm
Depth	30 mm

**Air flow monitor
LW 9**



Article	Art. No.
LW 9	0157.0779

- Air flow monitor for monitoring the minimum volumetric flows in the ventilation systems.
- Sensor cable length: 2.5 m.
- Screened cables must be used if the sensor cable is located in a cable duct.
- The sensor records the air flow and compares it to the setpoint value in the control unit.
- Control unit: Installation on a 35 mm profile rail.
- With LED function display for relay outputs and nominal voltages.
- Working and closed circuit function selection switch.
- With potential-free output via a changeover contact, e.g. for operating or fault messages.

Dimensions [mm]

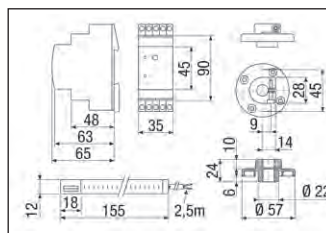

Features

Degree of protection	IP 10
Maximum load (inductive load)	2 A
Maximum load (ohmic load)	5 A
Min. flow velocity	1 m/s
Max. flow velocity	20 m/s
Max. ambient temperature	60 °C
Installation site	Channel

**Contactor
US 16 T**



Article	Art. No.
US 16 T	0157.0769

- Universal contactor for controlling fans and/or for loads.
- Control voltage: 230 V/50 Hz, 240 V/60 Hz.
- With 3 main contacts, 1 auxiliary contact (N/C contact).
- Water and dust protected.
- With integrated 35 mm profile rail.

Features

U _{nom}	600 V
Degree of protection	IP 55
Maximum load (ohmic load)	16 A
Type of installation	Surface-mounted
Width	100 mm
Height	160 mm
Depth	145 mm

**Water air heaters
WHP**

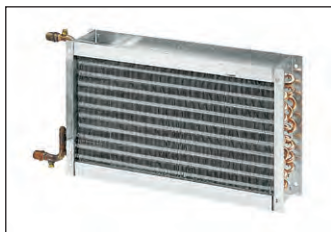

- Water air heater for ventilation systems.
- Water connection made of copper tubes with external threads.
- Mounting instructions: Install behind the fan at distances of at least 1 metre, to achieve equal flows.
- With air extraction and emptying. Take accessibility into account when installing.
- Frost protection must be supplied by the customer.
- With floating offset collecting pipes, to compensate for heat expansion.

Dimensions [mm]

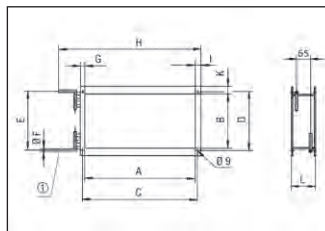

① Whitworth thread: 1/2" for WHP 22-18 and WHP 25-22; 3/4" for WHP 28-29, WHP 31-34 and WHP 35-43; 1" for WHP 50-55 and WHP 56-69

Common features

Housing material	Sheet steel, galvanised
Installation site	Channel
Inlet temperature	70 °C
Return flow temperature	50 °C
Max. water temperature	100 °C
Max. water pressure	8 bar

Article	Art. No.	Channel width dimension mm	Channel height dimension mm	Heater power rating W	A	B	C	D	E	F	G	H	I	K	L
WHP 22-18	0082.0111	500	250	17,700	500	250	520	270	272	16	20	645	25	35	110
WHP 25-22	0082.0112	500	300	21,700	500	300	520	320	322	16	20	645	25	35	110
WHP 28-29	0082.0113	600	300	29,400	600	300	620	320	318	22	20	745	25	35	110
WHP 31-34	0082.0114	600	350	33,600	600	350	620	370	368	22	20	745	25	35	110
WHP 35-43	0082.0115	700	400	43,000	700	400	720	420	418	22	20	845	25	35	110
WHP 50-55	0082.0123	800	500	55,000	740	500	820	520	475	28	40	1,006	55	35	120
WHP 56-69	0082.0124	1,000	500	69,000	940	500	1,020	520	475	28	40	1,206	55	35	120

Pressure losses

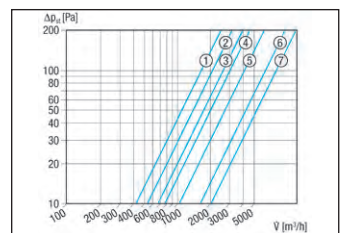

- ① WHP 22-18
- ② WHP 25-22
- ③ WHP 28-29
- ④ WHP 31-34
- ⑤ WHP 35-43
- ⑥ WHP 50-55
- ⑦ WHP 56-69

Temperature rise

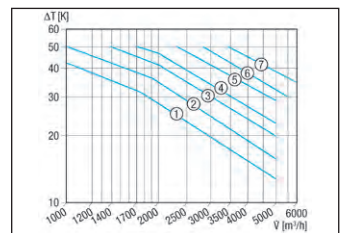

- ① WHP 22-18
- ② WHP 25-22
- ③ WHP 28-29
- ④ WHP 31-34
- ⑤ WHP 35-43
- ⑥ WHP 50-55
- ⑦ WHP 56-69

Roof fans

Example illustration of a ventilation installation

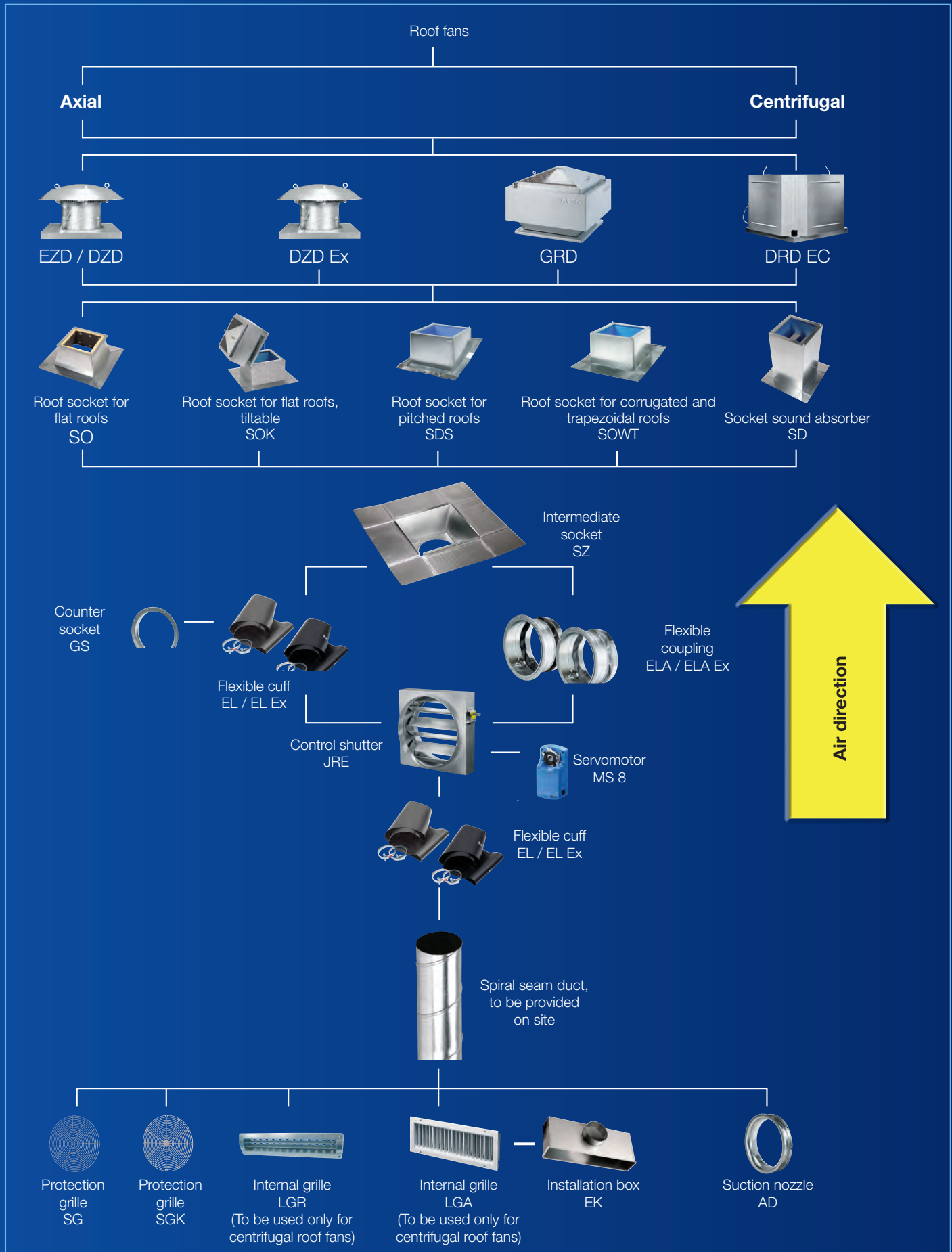

EZD / DZD axial roof fan

Up to 9,920 m³/h



Page 272

DZD axial roof fan, explosion proof

Up to 6,510 m³/h



Page 276

GRD centrifugal roof fan

With EC technology and integrated controller for constant pressure or constant volumetric flow up to 3,600 m³/h



Page 280

DRD EC centrifugal roof fan

With EC technology for particularly effective ventilation, up to 3,500 m³/h



Page 282

EHD centrifugal roof fan

Space-saving roof fan with extremely compact dimensions. High pressure capacity, up to 1,160 m³/h.



Page 284

Accessories

Roof sockets, socket sound absorbers, flexible cuffs, flexible couplings, protective grilles, shutters, etc.

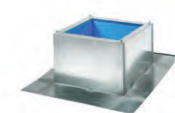

Page 286

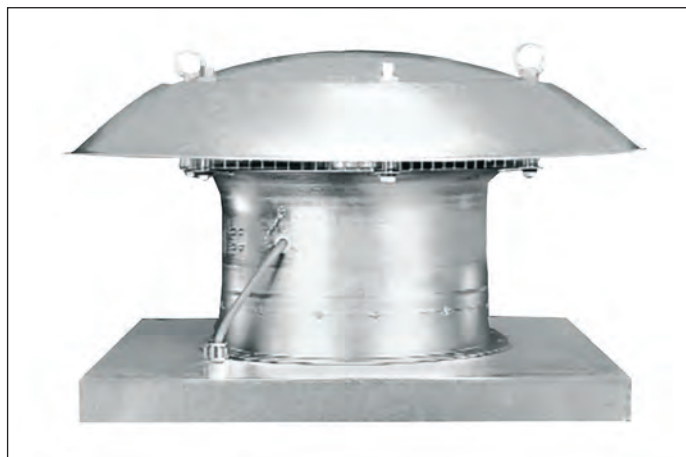

Features

- Housing, base plate, intake nozzle and rain protection cover made of galvanised sheet steel.
- Galvanized protective grille on the discharge side, protection against accidental contact in accordance with DIN EN ISO 13857.
- Sturdy eyebolts enable transport by crane.
- 8-blade impeller made of glass-fibre filled polyamide. Dynamically balanced at two levels, in accordance with performance level 6.3, DIN ISO 1940, Part 1.
- Can be switched to ventilation or air extraction (exception EZD ... E).

Air flow direction

- The following illustration shows the air flow direction:

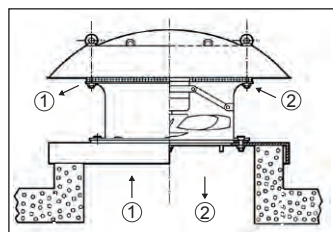

- ① Standard air flow direction: With air blown across the motor.
- ② Reversing mode: With air drawn across the motor.
- Reverse operation (exception EZD ... E): The volumetric flow is reduced by approx. 35 % with abnormal air flow direction.

Motor

- Asynchronous motor.
- Reversible. Exception: Fans with shaded-pole motors (“.../E”).
- Thermal overload protection as a standard feature.

AC motor

- EZD model series.
- Rated voltage 230 V, 50 Hz.
- “.../B” and “.../D” fans: Capacitor motors with operating capacitor in terminal box.
- “.../E” fans: Shaded-pole motors, non reversible.
- Degree of protection for EZD... D and ... E IP 54.
- Degree of protection for EZD... B IP 55.

Three-phase AC motor

- DZD model series.
- Rated voltage 400 V, 50 Hz.
- Degree of protection for DZD... D IP 54.
- Degree of protection for DZD... B and ... E IP 55.

Electrical connection

- Connecting cable, approx. 1.7 m long.

Safety instructions

- The fan may be operated only if the protection against accidental contact with the impeller is guaranteed to be in accordance with DIN EN ISO 13857.

Special versions

- The following special versions are available on request, at an extra cost:
 - Special voltages and frequencies.
 - Fans with enhanced anti-corrosion protection.
 - Impellers made of aluminium.
- Information on operation at temperatures occasionally below -20°C available upon request.
- If operating with frequency converters, the factory must be consulted.
- Feasibility must be checked in each case.

Technical data for units < 125 W

Article	Art. No.	U _{nom} V	f _{nom} Hz	Air flow volume m ³ /h	Rotating speed 1/min	P _{nom} W	I _{max} A	T _{max} at I _{max} °C	Sound power level L _{WA7} dB(A)	Weight kg
DN 250										
EZD 25/4 D	0087.0487	230	50	750	1,425	35	0.16	60	64	11.7
EZD 25/4 E	0087.0486	230	50	720	1,280	50	0.28	60	63	11.5
DZD 25/4 D	0087.0490	400	50	800	1,425	50	0.14	60	67	11.5
DN 300										
EZD 30/6 B	0087.0203	230	50	880	940	65	0.33	60	60	15.6
EZD 30/4 B	0087.0204	230	50	1,400	1,450	90	0.45	60	71	16.9
DZD 30/4 B	0087.0215	400	50	1,400	1,450	100	0.35	60	70	16.9

Technical data for units > 125 W according to ErP in Best Efficiency Point (BEP)

Article	Art. No.	U _{nom} V	f _{nom} Hz	Air flow volume m ³ /h	Sound power level _{WA7} dB(A)	Air volume _{nom} m ³ /h	Pressure _{P_{fs, nom}} Pa	Rotating speed n _{nom} 1/min	P _{nom} W	I _{nom} A	I _{max} A	T _{max} at I _{max} °C	Weight kg	Efficiency level N	Total efficiency η %
DN 250															
EZD 25/2 B	0087.0202	230	50	1,900	86	1,290 ¹⁾	112 ¹⁾	2,930 ¹⁾	180 ¹⁾	1 ¹⁾	1.3	60	16.9	40.2	29.2
DZD 25/2 B	0087.0213	400	50	1,840	91	1,100 ¹⁾	125 ¹⁾	2,830 ¹⁾	170 ¹⁾	0.35 ¹⁾	0.4	60	14.2	40.2	29.2
DN 300															
EZD 30/2 B	0087.0205	230	50	3,090	89	2,060 ¹⁾	135 ¹⁾	2,810 ¹⁾	375 ¹⁾	1.7 ¹⁾	2.3	60	20.4	43.1	34.2
DZD 30/2 B	0087.0216	400	50	3,100	89	2,040 ¹⁾	135 ¹⁾	2,830 ¹⁾	380 ¹⁾	0.85 ¹⁾	1	60	20.1	43.2	34.3
DN 355															
EZD 35/4 B	0087.0207	230	50	2,280	78	1,330 ¹⁾	65 ¹⁾	1,450 ¹⁾	125 ¹⁾	0.5 ¹⁾	0.65	60	24.4	43.6	31.4
DZD 35/4 B	0087.0218	400	50	2,325	78	1,210 ¹⁾	80 ¹⁾	1,470 ¹⁾	145 ¹⁾	0.57 ¹⁾	0.6	60	23.8	40.6	28.8
DN 400															
EZD 40/4 B	0087.0209	230	50	3,330	80	1,970 ¹⁾	84 ¹⁾	1,400 ¹⁾	235 ¹⁾	0.95 ¹⁾	1.4	60	28.7	43.9	33.5
DZD 40/4 B	0087.0222	400	50	3,260	79	1,770 ¹⁾	90 ¹⁾	1,365 ¹⁾	244 ¹⁾	0.6 ¹⁾	0.65	60	26.6	40.1	29.8
DN 500															
EZD 50/6 B	0087.0211	230	50	4,040	79	2,560 ¹⁾	55 ¹⁾	945 ¹⁾	245 ¹⁾	1.1 ¹⁾	1.3	60	39.7	40.3	30.1
DZD 50/6 B	0087.0225	400	50	4,160	80	2,450 ¹⁾	62 ¹⁾	945 ¹⁾	245 ¹⁾	0.65 ¹⁾	0.7	60	38	40.4	30.1
DZD 50/4 B	0087.0226	400	50	6,170	91	3,600 ¹⁾	140 ¹⁾	1,400 ¹⁾	665 ¹⁾	1.2 ¹⁾	1.4	60	38.5	44.2	36.7
DN 600															
DZD 60/6 B	0087.0228	400	50	7,030	84	4,320 ¹⁾	88 ¹⁾	935 ¹⁾	530 ¹⁾	1.1 ¹⁾	1.3	60	45.5	40.3	32.1
DZD 60/4 B	0087.0229	400	50	9,920	94	6,050 ¹⁾	175 ¹⁾	1,330 ¹⁾	1,445 ¹⁾	2.4 ¹⁾	3.1	60	62.5	40.2	34.8

¹⁾ In opt. efficiency

BEP measured in measurement category C, static efficiency category. For further ErP data, see www.maico-fans.com. Calculation of energy efficiency without protective grille and roof cowl.

Dimensions [mm]

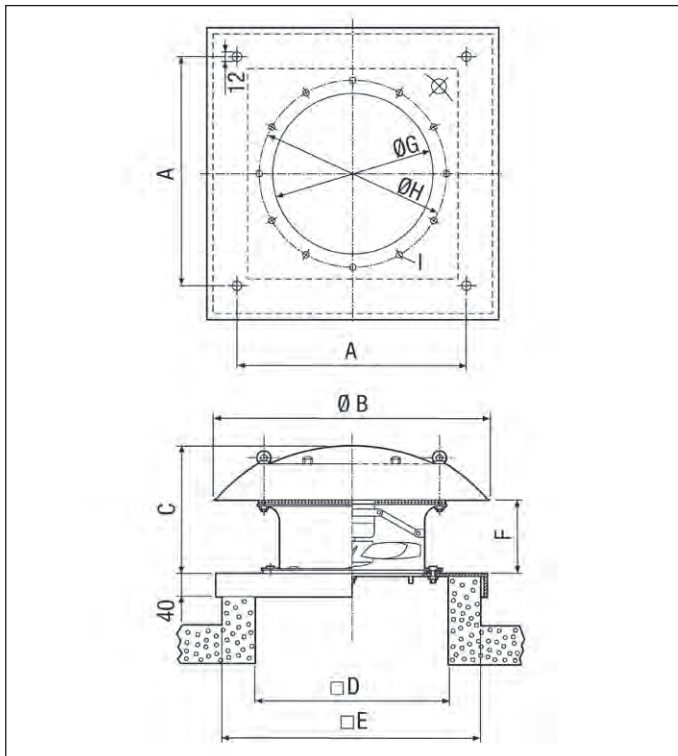

Nominal size	A	B	C	D	E	F	G	H	I
DN 250	500	570	285	355	560	170	263	286	7
DN 300	570	660	335	405	630	190	313	356	9
DN 355	610	720	340	455	670	190	363	395	9
DN 400	650	830	375	505	710	190	413	438	9
DN 500	800	940	380	605	860	190	513	541	9
DN 600	840	1,100	420	720	900	190	613	674	11

Characteristic curves for DN 250

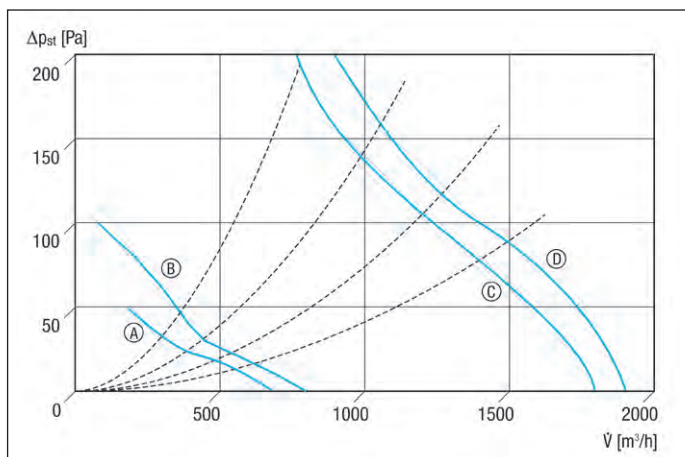

- Ⓐ EZD 25/4 E
- Ⓑ EZD, DZD 25/4 D
- Ⓒ DZD 25/2 B
- Ⓓ EZD 25/2 B

Characteristic curves for DN 300

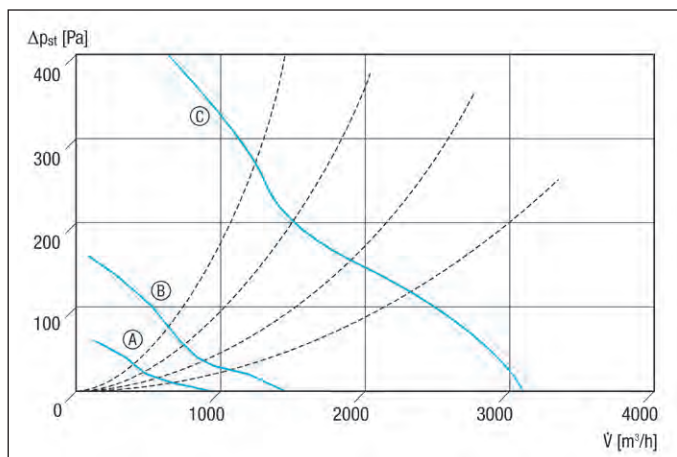

- Ⓐ EZD 30/6 B
- Ⓑ EZD, DZD 30/4 B
- Ⓒ EZD, DZD 30/2 B

Characteristic curves for DN 350 and DN 400

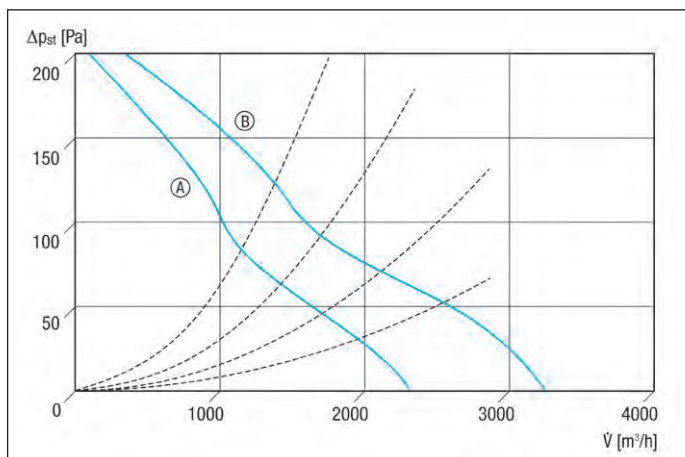

- Ⓐ EZD, DZD 35/4 B
- Ⓑ EZD, DZD 40/4 B

Characteristic curves for DN 500 and DN 600

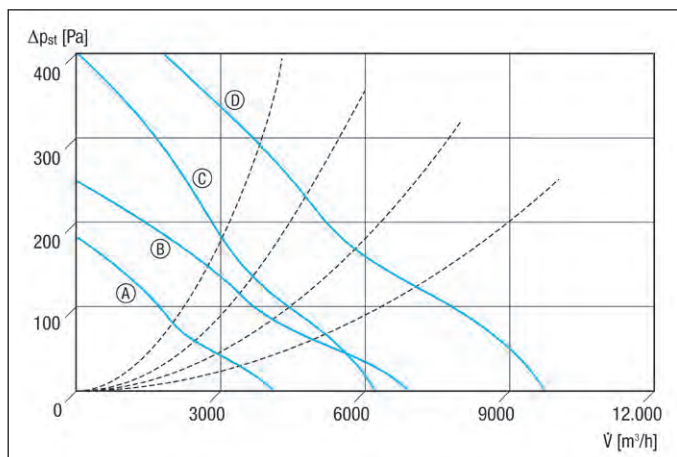

- Ⓐ EZD 50/6 B
- Ⓑ DZD 60/6 B
- Ⓒ DZD 50/4 B
- Ⓓ DZD 60/4 B

Accessories selection table

	EZD 25/4 D	EZD 25/4 E	EZD 25/2 B	DZD 25/4 D	DZD 25/2 B	EZD 30/6 B	EZD 30/4 B	EZD 30/2 B	DZD 30/4 B	DZD 30/2 B	see
General accessories											
Control shutter	JRE 25	JRE 25	JRE 25	JRE 25	JRE 25	JRE 30	JRE 30	JRE 30	JRE 30	JRE 30	P. 293
Servomotor	MS 8 MS 8 P	MS 8 MS 8 P	MS 8 MS 8 P	MS 8 MS 8 P	MS 8 MS 8 P	MS 8 MS 8 P	MS 8 MS 8 P	MS 8 MS 8 P	MS 8 MS 8 P	MS 8 MS 8 P	P. 293
Protective grille, metal	SG 25	SG 25	SG 25	SG 25	SG 25	SG 30	SG 30	SG 30	SG 30	SG 30	P. 289
Protective grille, synthetic material	SGK 25	SGK 25	SGK 25	SGK 25	SGK 25	SGK 30	SGK 30	SGK 30	SGK 30	SGK 30	P. 290
Flexible coupling	ELA 25	ELA 25	ELA 25	ELA 25	ELA 25	ELA 30	ELA 30	ELA 30	ELA 30	ELA 30	P. 292
Suction nozzle	AD 25	AD 25	AD 25	AD 25	AD 25	AD 30	AD 30	AD 30	AD 30	AD 30	P. 289
Socket sound absorber	SD 25	SD 25	SD 25	SD 25	SD 25	SD 31	SD 31	SD 31	SD 31	SD 31	P. 288
Reversing switch	W 1 WU 1	–	W 1 WU 1	W 1 WU 1	W 1 WU 1	W 1 WU 1	W 1 WU 1	W 1 WU 1	W 1 WU 1	W 1 WU 1	P. 334
Speed controller	ST 1 STU 1	ST 1 STU 1	ST 2,5 STU 2,5	–	–	ST 1 STU 1	ST 1 STU 1	ST 2,5 STU 2,5	–	–	P. 338
Speed controller, distribution board	–	–	STS 2,5	–	–	–	–	STS 2,5	–	–	P. 339
Speed controller, reversing switch	STW 1	–	STW 2,5	–	–	STW 1	STW 1	STW 2,5	–	–	P. 339
5-step transformer	TRE 0,4-2	TRE 0,4-2	TRE 1,6-2	TR 0,4-2	TR 0,8-2	TRE 0,4-2	TRE 0,6-2	TRE 3,3-2	TR 0,4-2	TR 2,5-2	P. 340
5-step transformer, control cabinet	TRE 1,6 S-2	TRE 1,6 S-2	TRE 1,6 S-2	TR 0,8 S-2	TR 0,8 S-2	TRE 1,6 S-2	TRE 1,6 S-2	TRE 3,3 S-2	TR 0,8 S-2	TR 2,5 S-2	P. 341
5-step switch for TRE...S -2/ TR...S-2 5-step transformer	ESS 20	ESS 20	ESS 20	DSS 20	DSS 20	ESS 20	ESS 20	ESS 20	DSS 20	DSS 20	P. 341
Temperature control system	EAT 6 G/1 EAT 6 TG	EAT 6 G/1 EAT 6 TG	EAT 6 G/1 EAT 6 TG	–	–	EAT 6 G/1 EAT 6 TG	EAT 6 G/1 EAT 6 TG	EAT 6 G/1 EAT 6 TG	–	–	P. 345
Roof socket for flat roofs	SO 25	SO 25	SO 25	SO 25	SO 25	SO 30	SO 30	SO 30	SO 30	SO 30	P. 286
Roof socket for flat roofs, tiltable	SOK 25	SOK 25	SOK 25	SOK 25	SOK 25	SOK 31	SOK 31	SOK 31	SOK 31	SOK 31	P. 286
Roof socket for pitched roofs	SDS 25	SDS 25	SDS 25	SDS 25	SDS 25	SDS 31	SDS 31	SDS 31	SDS 31	SDS 31	P. 287
Roof socket for corrugated and trapezoidal roofs	SOWT 25	SOWT 25	SOWT 25	SOWT 25	SOWT 25	SOWT 31	SOWT 31	SOWT 31	SOWT 31	SOWT 31	P. 287
Intermediate socket	SZ 25	SZ 25	SZ 25	SZ 25	SZ 25	SZ 31	SZ 31	SZ 31	SZ 31	SZ 31	P. 288

	EZD 35/4 B	DZD 35/4 B	EZD 40/4 B	DZD 40/4 B	EZD 50/6 B	DZD 50/6 B	DZD 50/4 B	DZD 60/6 B	DZD 60/4 B	see
General accessories										
Control shutter	JRE 35	JRE 35	JRE 40	JRE 40	JRE 50	JRE 50	JRE 50	JRE 60	JRE 60	P. 293
Servomotor	MS 8 MS 8 P	MS 8 MS 8 P	MS 8 MS 8 P	MS 8 MS 8 P	MS 8 MS 8 P	MS 8 MS 8 P	MS 8 MS 8 P	MS 8 MS 8 P	MS 8 MS 8 P	P. 293
Protective grille, metal	SG 35	SG 35	SG 40	SG 40	SG 50	SG 50	SG 50	SG 60	SG 60	P. 289
Protective grille, synthetic material	SGK 35	SGK 35	SGK 40	SGK 40	–	–	–	–	–	P. 290
Flexible coupling	ELA 35	ELA 35	ELA 40	ELA 40	ELA 50	ELA 50	ELA 50	ELA 60	ELA 60	P. 292
Suction nozzle	AD 35	AD 35	AD 40	AD 40	AD 50	AD 50	AD 50	AD 60	AD 60	P. 289
Socket sound absorber	SD 35	SD 35	SD 40	SD 40	SD 50	SD 50	SD 50	–	–	P. 288
Reversing switch	W 1 WU 1	W 1 WU 1	W 1 WU 1	W 1 WU 1	W 1 WU 1	W 1 WU 1	W 1 WU 1	W 1 WU 1	W 1 WU 1	P. 334
Speed controller	ST 1 STU 1	–	ST 2,5 STU 2,5	–	ST 2,5 STU 2,5	–	–	–	–	P. 338
Speed controller, distribution board	STS 2,5	–	STS 2,5	–	STS 2,5	–	–	–	–	P. 339
Speed controller, reversing switch	STW 1	–	STW 2,5	–	STW 2,5	–	–	–	–	P. 339
5-step transformer	TRE 1,6-2	TR 0,8-2	TRE 1,6-2	TR 0,8-2	TRE 1,6-2	TR 0,8-2	TR 2,5-2	TR 2,5-2	TR 6,6-2	P. 340
5-step transformer, control cabinet	TRE 1,6 S-2	TR 0,8 S-2	TRE 1,6 S-2	TR 0,8 S-2	TRE 1,6 S-2	TR 0,8 S-2	TR 2,5 S-2	TR 2,5 S-2	TR 6,6 S-2	P. 341
5-step switch for TRE...S -2/ TR...S-2 5-step transformer	ESS 20	DSS 20	ESS 20	DSS 20	ESS 20	DSS 20	DSS 20	DSS 20	DSS 20	P. 341
Temperature control system	EAT 6 G/1 EAT 6 TG	–	EAT 6 G/1 EAT 6 TG	–	EAT 6 G/1 EAT 6 TG	–	–	–	–	P. 345
Roof socket for flat roofs	SO 35	SO 35	SO 40	SO 40	SO 50	SO 50	SO 50	SO 60	SO 60	P. 286
Roof socket for flat roofs, tiltable	SOK 35	SOK 35	–	–	–	–	–	–	–	P. 286
Roof socket for pitched roofs	SDS 35	SDS 35	SDS 40	SDS 40	SDS 50	SDS 50	SDS 50	–	–	P. 287
Roof socket for corrugated and trapezoidal roofs	SOWT 35	SOWT 35	SOWT 40	SOWT 40	SOWT 50	SOWT 50	SOWT 50	–	–	P. 287
Intermediate socket	SZ 35	SZ 35	SZ 40	SZ 40	–	–	–	–	–	P. 288

DZD-Ex axial roof fan, explosion proof



Features

- Explosion protection in accordance with ATEX.
- Ex II 2G Ex e IIB+H₂ T3/T4 Gb.
- For usage temperatures of -20°C ≤ Ta ≤ +40°C.
- MAICO Ex fans fulfil the safety requirements of European Directive 2014/34/EU for units and protective systems in explosion-endangered areas.
- For zone 1 and 2.
- Base plate, intake nozzle and rain protection cover made of galvanised sheet steel.
- Horizontal air outlet direction.
- Sturdy eyebolts enable transport by crane.
- Can be switched to ventilation or air extraction.

- Reversing mode: The volumetric flow is reduced by approx. 35 % with abnormal air flow direction.

Motor

- Robust motor with ball bearings, maintenance-free.
- Motor protection class IP 54.

Electrical connection

- Connecting cable, approx. 1.7 m long.
- Separate terminal box, explosion proof, with cable screw-connections.

Safety instructions

- Speed control permitted with transformer TR.... Exception: DZ.. 35/2 B Ex e.

- The temperature in the fan unit is monitored by PTC thermistors. The PTC thermistors must be connected to a triggering system (safety device according to Directive 2014/34/EU), that separates the fan permanently from the power if the temperature gets too hot.
- The MAICO PTC thermistor triggering device MVS 6 or TMS is recommended as the triggering system.
- The fan may be operated only if the protection against accidental contact with the impeller is guaranteed to be in accordance with DIN EN ISO 13857 for fans with free inlet and outlet, e.g. with an SG protective grille.

Required safety technology

- A PTC thermistor triggering device is needed to fuse the DZD-Ex units.
- Maico provides the MVS 6 PTC thermistor triggering device and TMS for this purpose.
- MVS 6 PTC thermistor triggering device
 - Independent complete system.
 - For monitoring the maximum motor temperature.
 - Type-examination tested according to Directive 2014/34/EU (ATEX).
 - Installation exclusively in non-explosive areas.

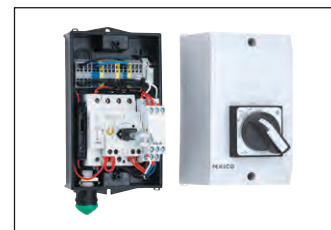

- TMS PTC thermistor triggering device
 - For monitoring the maximum motor temperature.
 - Suitable for installation in control cabinets
 - Type-examination tested according to Directive 2014/34/EU (ATEX).
 - Installation exclusively in non-explosive areas.



Special versions

- Special voltages are available as special versions on request, at an extra cost.
- Information on operation at temperatures occasionally below -20 °C available upon request.
- Feasibility must be checked in each case.

Technical data

Article	Art. No.	U _{nom}	f _{nom}	Air flow volume	Rotating speed	P _{nom}	I _{nom}	Sound power level L _{WAS}	Degree of protection	Temperature class	Insulation class	Weight
		V	Hz	m ³ /h	1/min	W	A	dB(A)	IP			kg
DN 250												
DZD 25/4 B Ex e	0087.0796	400	50	800	1,475	38	0.19	68	54	T4	F	14.3
DZD 25/2 B Ex e	0087.0797	400	50	1,600	2,870	140	0.29	87	54	T4	F	14.6
DN 300												
DZD 30/6 B Ex e	0087.0798	400	50	940	985	25	0.12	64	54	T4	F	19.7
DZD 30/4 B Ex e	0087.0799	400	50	1,390	1,475	95	0.48	74	54	T3	F	17.5
DZD 30/2 B Ex e	0087.0800	400	50	2,690	2,880	300	0.53	91	54	T3	F	20.4
DN 355												
DZD 35/6 B Ex e	0087.0801	400	50	1,370	965	40	0.13	69	54	T4	F	22.7
DZD 35/4 B Ex e	0087.0802	400	50	2,060	1,450	130	0.49	77	54	T3	F	20.7
DZD 35/2 B Ex e	0087.0803	400	50	4,280	2,880	620	1.3	97	54	T3	F	24.1
DN 400												
DZD 40/6 B Ex e	0087.0804	400	50	2,130	980	100	0.55	74	54	T4	F	26.6
DZD 40/4 B Ex e	0087.0805	400	50	3,200	1,465	170	0.55	84	54	T4	F	26.6
DN 500												
DZD 50/6 B Ex e	0087.0806	400	50	3,870	950	180	0.58	77	54	T4	F	33
DZD 50/4 B Ex e	0087.0807	400	50	5,830	1,425	485	0.92	88	54	T3	F	39
DN 600												
DZD 60/6 B Ex e	0087.0808	400	50	6,510	950	365	0.74	83	54	T3	F	45.5

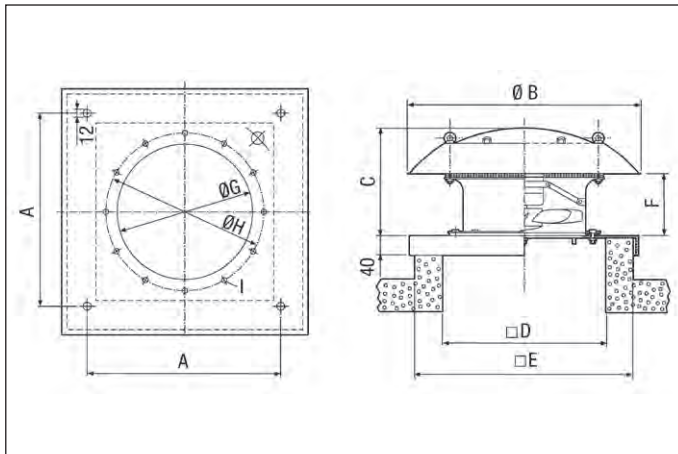

Dimensions [mm]

Nominal size	A	B	C	D	E	F	G	H	I
DZD-Ex - DN 250	500	570	285	355	560	170	263	286	7
DZD-Ex - DN 300	570	660	335	405	630	190	313	356	9
DZD-Ex - DN 355	610	720	340	455	670	190	363	395	9
DZD-Ex - DN 400	650	830	375	505	710	190	413	438	9
DZD-Ex - DN 500	800	940	380	605	860	190	513	541	9
DZD-Ex - DN 600	840	1,100	420	720	900	190	613	674	11

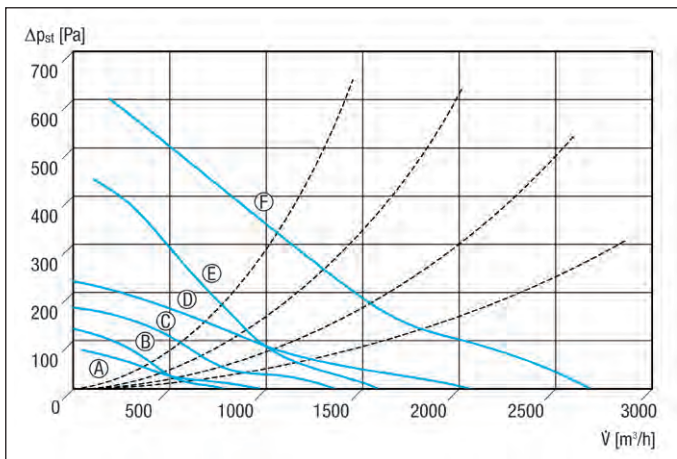
Characteristic curves for DN 250 to DN 350

- Ⓐ DZD 30/6 B Ex
- Ⓑ DZD 25/4 B Ex
- Ⓒ DZD 30/4 B Ex
- Ⓓ DZD 35/4 B Ex
- Ⓔ DZD 25/2 B Ex
- Ⓕ DZD 30/2 B Ex

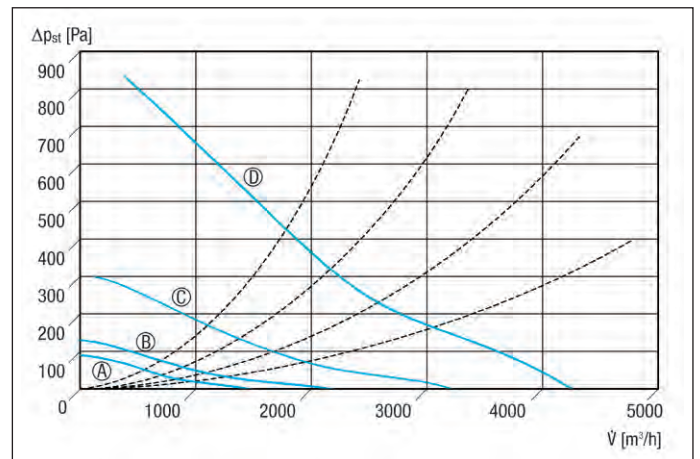
Characteristic curves for DN 350 to DN 400

- Ⓐ DZD 35/6 B Ex
- Ⓑ DZD 40/6 B Ex
- Ⓒ DZD 40/4 B Ex
- Ⓓ DZD 35/2 B Ex

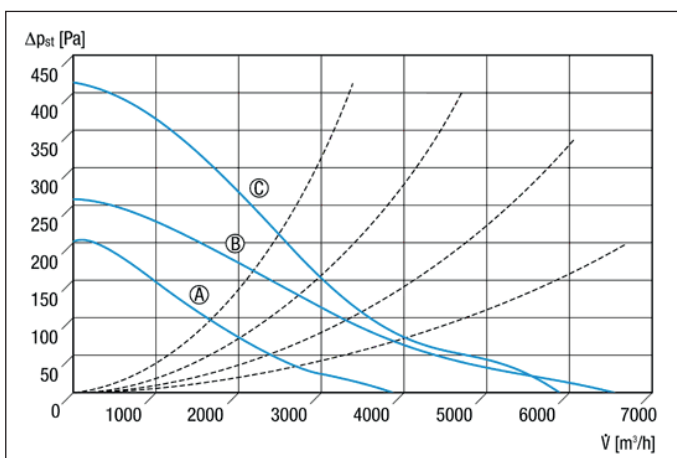
Characteristic curves for DN 500 to DN 600

- Ⓐ DZD 50/6 B Ex
- Ⓑ DZD 60/6 B Ex
- Ⓒ DZD 50/4 B Ex

Accessories selection table

	DZD 25/4 B Ex e	DZD 25/2 B Ex e	DZD 30/6 B Ex e	DZD 30/4 B Ex e	DZD 30/2 B Ex e	DZD 35/6 B Ex e	DZD 35/4 B Ex e	see
Specific accessories								
Flexible coupling	ELA 25 Ex	ELA 25 Ex	ELA 30 Ex	ELA 30 Ex	ELA 30 Ex	ELA 35 Ex	ELA 35 Ex	P. 292
Flexible cuff	EL 25 Ex	EL 25 Ex	EL 30 Ex	EL 30 Ex	EL 30 Ex	EL 35 Ex	EL 35 Ex	P. 291
PTC thermistor triggering device	MVS 6	MVS 6	MVS 6	MVS 6	MVS 6	MVS 6	MVS 6	P. 336
Machine protection relay thermistor	TMS	TMS	TMS	TMS	TMS	TMS	TMS	P. 336
General accessories								
Protective grille, metal	SG 25	SG 25	SG 30	SG 30	SG 30	SG 35	SG 35	P. 289
Counter socket	GS 25	GS 25	GS 30	GS 30	GS 30	GS 35	GS 35	P. 291
Socket sound absorber	SD 25	SD 25	SD 31	SD 31	SD 31	SD 35	SD 35	P. 288
5-step transformer	TR 0,4-2	TR 0,4-2	TR 0,8-2	TR 0,8-2	TR 2,5-2	TR 0,8-2	TR 0,8-2	P. 340
Roof socket for flat roofs	SO 25	SO 25	SO 30	SO 30	SO 30	SO 35	SO 35	P. 286
Roof socket for pitched roofs	SDS 25	SDS 25	SDS 31	SDS 31	SDS 31	SDS 35	SDS 35	P. 287
Roof socket for corrugated and trapezoidal roofs	SOWT 25	SOWT 25	SOWT 31	SOWT 31	SOWT 31	SOWT 35	SOWT 35	P. 287
Intermediate socket	SZ 25	SZ 25	SZ 31	SZ 31	SZ 31	SZ 35	SZ 35	P. 288

	DZD 35/2 B Ex e	DZD 40/6 B Ex e	DZD 40/4 B Ex e	DZD 50/6 B Ex e	DZD 50/4 B Ex e	DZD 60/6 B Ex e	see
Specific accessories							
Flexible coupling	ELA 35 Ex	ELA 40 Ex	ELA 40 Ex	ELA 50 Ex	ELA 50 Ex	ELA 60 Ex	P. 292
Flexible cuff	EL 35 Ex	EL 40 Ex	EL 40 Ex	EL 50 Ex	EL 50 Ex	EL 60 Ex	P. 291
PTC thermistor triggering device	MVS 6	MVS 6	MVS 6	MVS 6	MVS 6	MVS 6	P. 336
Machine protection relay thermistor	TMS	TMS	TMS	TMS	TMS	TMS	P. 336
General accessories							
Protective grille, metal	SG 35	SG 40	SG 40	SG 50	SG 50	SG 60	P. 289
Counter socket	GS 35	GS 40	GS 40	GS 50	GS 50	GS 60	P. 291
Socket sound absorber	SD 35	SD 40	SD 40	SD 50	SD 50	–	P. 288
5-step transformer	–	TR 0,8-2	TR 0,8-2	TR 0,8-2	TR 2,5-2	TR 2,5-2	P. 340
Roof socket for flat roofs	SO 35	SO 40	SO 40	SO 50	SO 50	SO 60	P. 286
Roof socket for pitched roofs	SDS 35	SDS 40	SDS 40	SDS 50	SDS 50	–	P. 287
Roof socket for corrugated and trapezoidal roofs	SOWT 35	SOWT 40	SOWT 40	SOWT 50	SOWT 50	–	P. 287
Intermediate socket	SZ 35	SZ 40	SZ 40	–	–	–	P. 288

GRD centrifugal roof fan



Features

- Pressure or volumetric constancy can be set.
- 2 speed levels for day/night operations.
- Day/night operation can be set using 2 reference volumetric flows or 2 reference pressure levels.
- With automatic fault message.
- Can be used for central ventilation systems in accordance with DIN 18017-3.
- Adjustments can be undertaken without pressure or volumetric flow having to be measured.
- Housing easily detachable for cleaning purposes.
- Galvanized protective grille on the discharge side, protection against accidental contact in accordance with DIN EN ISO 13857.
- Sturdy eyebolts enable transport by crane.

- Impeller with blades curved to the rear, dynamically balanced at two levels, in accordance with performance level 6.3, DIN ISO 1940.
- Impeller made of glass-fibre filled polypropylene.
- With service switch.
- IP 45 degree of protection.

Motor

- EC motor.
- Overload protection as standard.
- No motor protection measures needed.

Electrical connection

- 2 separate mains connections (230 V, 50 Hz) needed for fan and control unit.
- Mains connections 3 x 1.5 mm² each, type NYM-J / NYM-O.
- 6-core shielded control cable between control and fan.
- Control cable with maximum length of 200 m, maximum external diameter of 6 mm, e.g. LiYCY (6 x 0.25 mm² or 6 x 0.34 mm²).

Control unit

▪ **Control unit included in scope of delivery.**

- Any installation inside the building.
- Pressure sensor fitted in fan housing ready for use.
- Control unit for operating in constant pressure / constant volumetric flow mode.
- A minimum volumetric flow is required for the correct function:
 - GRD 22 - 150 m³/h
 - GRD 25 - 200 m³/h
 - GRD 31 - 250 m³/h

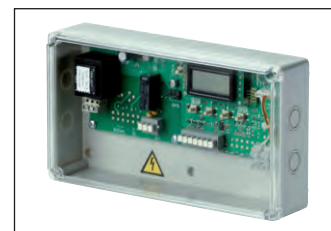

Technical data for units > 125 W according to ErP in Best Efficiency Point (BEP)

Article	Art. No.	U _{nom}	f _{nom}	Air flow volume	Sound power level L _{WA5}	Air volume _{nom}	Pressure P _{fs, nom}	Rotating speed n _{nom}	P _{nom}	I _{nom}	I _{max}	T _{max} at I _{max}	Weight	Efficiency level N	Total efficiency η
		V	Hz	m ³ /h	dB(A)	m ³ /h	Pa	1/min	W	A	A	°C	kg		%
DN 224															
GRD 22	0087.0016	230	50	1,970	75	950 ¹⁾	370 ¹⁾	1,810 ¹⁾	280 ¹⁾	1.7 ¹⁾	1.9	50	27.3	62.4	46.7
DN 250															
GRD 25	0087.0017	230	50	2,690	75	1,370 ¹⁾	390 ¹⁾	1,660 ¹⁾	410 ¹⁾	2.5 ¹⁾	2.6	50	30.7	62.2	47.3
DN 315															
GRD 31	0087.0018	230	50	3,600	74	2,020 ¹⁾	380 ¹⁾	1,490 ¹⁾	600 ¹⁾	3.5 ¹⁾	3.6	50	42.3	65.6	48.8

¹⁾ In opt. efficiency

BEP measured in measurement category C, static efficiency category. VSD integrated. For further ErP data, see www.maico-fans.com. Calculation of energy efficiency without housing.



Dimensions [mm]

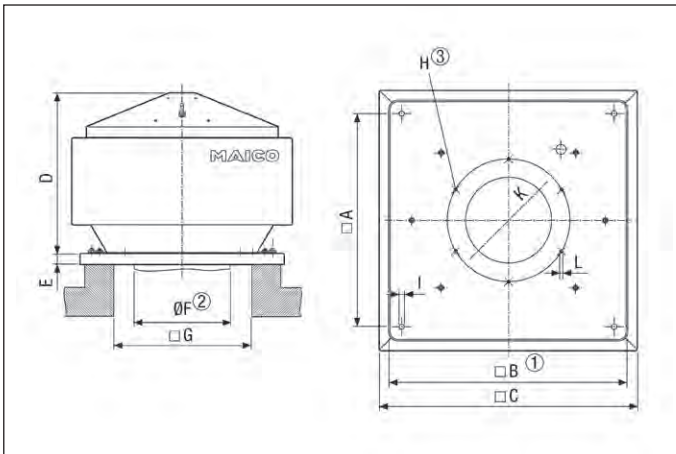

Article	A	B	C	D	E	F	G	H	I	K	L
GRD 22	460	520	554	407	30	224	340	3	12	259	M6
GRD 25	500	560	614	441	30	250	380	6	12	286	M6
GRD 31	570	630	724	517	30	315	440	8	12	356	M8

- ① Clear width
- ② External duct diameter
- ③ Number of holes

Characteristic curves for GRD

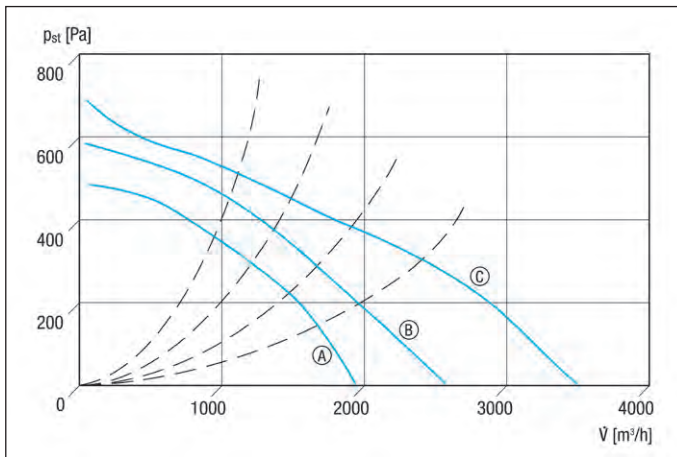

- Ⓐ GRD 22
- Ⓑ GRD 25
- Ⓒ GRD 31

Accessories selection table

	GRD 22	GRD 25	GRD 31	see
General accessories				
Flexible coupling	ELA 22	ELA 25	ELA 31	P. 292
Socket sound absorber	SD 22	SD 25	SD 31	P. 288
Roof socket for flat roofs	SO 22	SO 25	SO 30	P. 286
Roof socket for flat roofs, tiltable	SOK 22	SOK 25	SOK 31	P. 286
Roof socket for pitched roofs	SDS 22	SDS 25	SDS 31	P. 287
Roof socket for corrugated and trapezoidal roofs	SOWT 22	SOWT 25	SOWT 31	P. 287
Intermediate socket	SZ 22	SZ 25	SZ 31	P. 288



Features

- Low energy consumption thanks to EC technology.
- Attractive aluminium housing.
- Easily detachable cover.
- Galvanised protective grille on the discharge side with protection against accidental contact.
- Sturdy eyebolts enable transport by crane.
- Impeller with plastic blades curved to the rear, dynamically balanced at two levels, in accordance with performance level 6.3, DIN ISO 1940.

Motor

- DC motor.
- Rated voltage 230 V, 50 Hz.
- Thermal overload protection as a standard feature.
- Speed output.
- 0 - 10 V DC control input
- Soft start.
- IP X4 degree of protection with closed housing cover.

Electrical connection

- In terminal box, easily accessible once housing cover has been removed.

Security instructions

- The fan can be operated only if the protection against accidental contact with the impeller is guaranteed for fans with a free inlet.

Technical data

Article	Art. No.	U _{nom} V	f _{nom} Hz	Air flow volume m ³ /h	Rotating speed 1/min	P _{nom} W	I _{max} A	T _{max} at I _{max} °C	Sound power level L _{WA5} dB(A)	Weight kg
DN 180										
DRD 18 EC	0087.0170	230	50	950	1,990	85	0.69	60	64	7.1
DN 224										
DRD 22 EC	0087.0171	230	50	2,125	1,840	165	1.3	60	73	9.3
DN 315										
DRD 31 EC	0087.0172	230	50	3,500	1,570	370	1.65	60	74	15.8

Dimensions [mm]

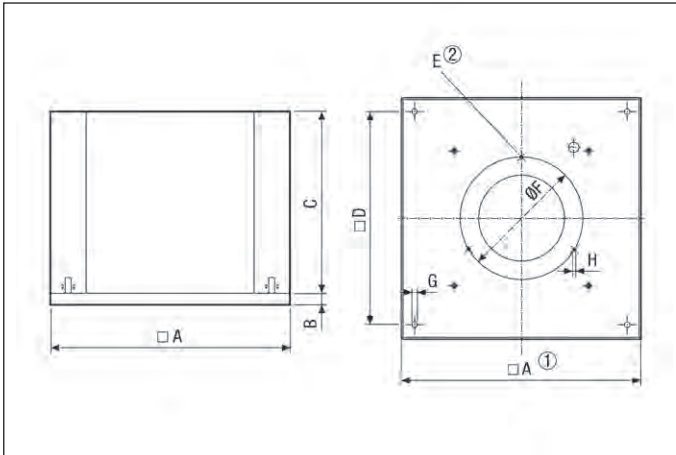

- ① Clear width
② Number of holes

Article	A	B	C	D	E	F	G
DRD 18 EC	480	30	270	420	3	213	12
DRD 22 EC	520	30	331	460	3	259	12
DRD 31 EC	630	30	400	570	3	356	12

Characteristic curve

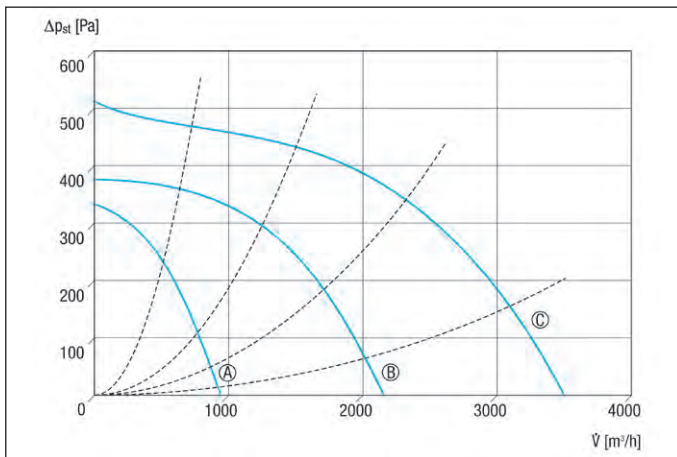

- Ⓐ DRD 18 EC
Ⓑ DRD 22 EC
Ⓒ DRD 31 EC

Accessories selection table

	DRD 18 EC	DRD 22 EC	DRD 31 EC	see
General accessories				
Flexible coupling	ELA 18	ELA 22	ELA 31	P. 292
Socket sound absorber	SD 18	SD 22	SD 31	P. 288
Potentiometer	ST EC 010 ST EC 230 ST EC 3	ST EC 010 ST EC 230 ST EC 3	ST EC 010 ST EC 230 ST EC 3	P. 337
Pressure and temperature control system	EAT EC	EAT EC	EAT EC	P. 345
Roof socket for flat roofs	SO 18	SO 22	SO 30	P. 286
Roof socket for flat roofs, tiltable	SOK 18	SOK 22	SOK 31	P. 286
Roof socket for pitched roofs	SDS 18	SDS 22	SDS 31	P. 287
Roof socket for corrugated and trapezoidal roofs	SOWT 18	SOWT 22	SOWT 31	P. 287
Intermediate socket	SZ 18	SZ 22	SZ 31	P. 288



Features

- Space-saving roof fan with extremely compact dimensions.
- For air extraction.
- Attractive housing made of galvanised and powder-coated sheet steel.
- Cover made of aluminium.
- The cover is easily detachable for cleaning purposes.
- Coated grille protecting against intervention.
- Centrifugal impeller with backwards curved blades.
- IP X5 degree of protection.

Motor

- External rotor - capacitor motor.
- Operating capacitor in the terminal box is ready to be connected.
- Speed controllable.
- Thermal overload protection as standard feature.
- Robust motor with ball bearings, maintenance-free.

Electrical connection

- Connection to terminal block in the housing.

Mounting instructions

- Thanks to its low weight, cranes or goods lifts are not needed to transport the EHD on to the roof.

Safety instructions

- The fan can be operated only if the protection against accidental contact with the impeller is guaranteed to be in accordance with DIN EN 13857 for fans with a free inlet.

Technical data

Article	Art. No.	U _{nom} V	f _{nom} Hz	Air flow volume m ³ /h	P _{nom} W	I _{max} A	T _{max} at I _{max} °C	Sound power level L _{WAS} dB(A)	Weight kg	Mains cable mm ²
DN 100										
EHD 10	0087.0300	230	50	300	50	0.22	70	70	4.5	3 x 1.5
DN 125										
EHD 12	0087.0301	230	50	325	49	0.22	70	71	4.4	3 x 1.5
DN 150										
EHD 15	0087.0302	230	50	550	82	0.36	60	70	6.7	3 x 1.5
DN 160										
EHD 16	0087.0303	230	50	700	102	0.45	70	72	7.1	3 x 1.5
DN 200										
EHD 20	0087.0304	230	50	755	107	0.47	50	73	7.7	3 x 1.5
DN 250										
EHD 25	0087.0305	230	50	825	148	0.65	50	69	8	3 x 1.5
DN 315										
EHD 31	0087.0306	230	50	1,160	247	1.1	60	73	9.8	3 x 1.5

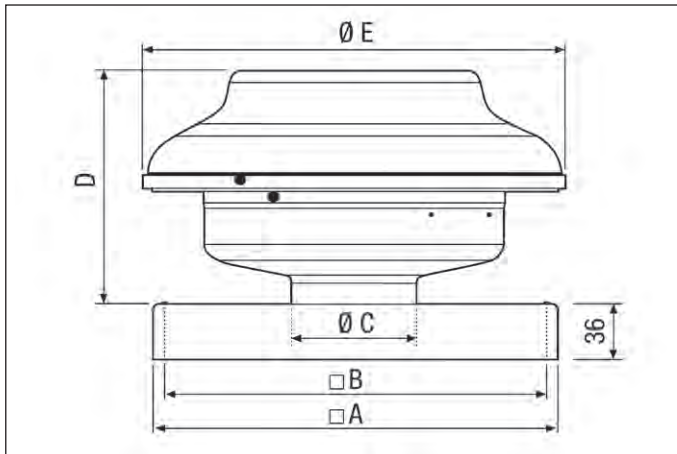
Dimensions [mm]

Article	A	B	C	D	E
EHD 10	300	265	98	225	333
EHD 12	300	265	122	225	333
EHD 15	400	360	147	266	405
EHD 16	400	360	157	266	405
EHD 20	400	360	198	266	405
EHD 25	400	360	248	266	405
EHD 31	400	360	314	322	484

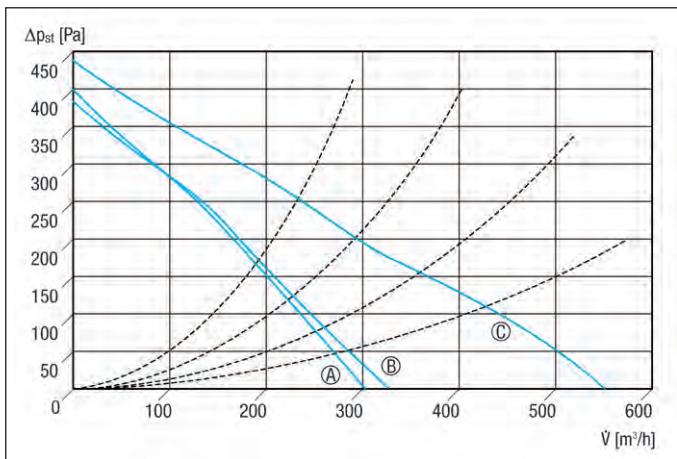
Characteristic curves for EHD 10, EHD 12, EHD 15

Ⓐ EHD 10
 Ⓑ EHD 12
 Ⓒ EHD 15

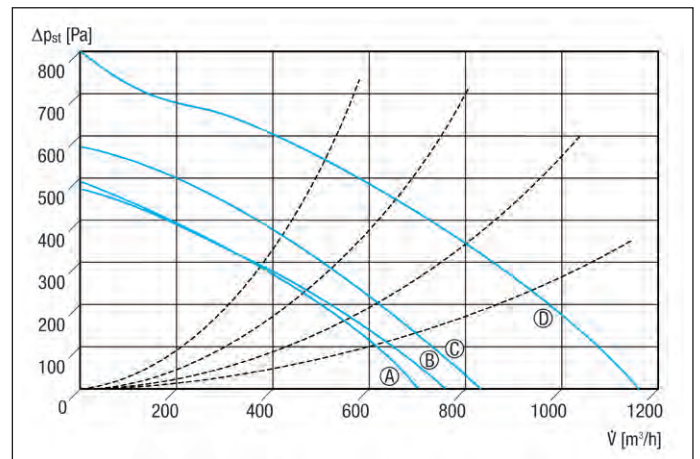
Characteristic curves for EHD 16 to EHD 31

Ⓐ EHD 16
 Ⓑ EHD 20
 Ⓒ EHD 25
 Ⓓ EHD 31

Accessories selection table

	EHD 10	EHD 12	EHD 15	EHD 16	EHD 20	EHD 25	EHD 31	see
General accessories								
Automatic backflow preventer	AVM 10	AVM 12	AVM 15	AVM 16	AVM 20	AVM 25	AVM 31	P. 301
Protective grille	SGR 10	SGR 12	SGR 16	SGR 16	SGR 20	SGR 25	SGR 31	P. 314
Speed controller	ST 1 STU 1	ST 1 STU 1	ST 1 STU 1	ST 1 STU 1	ST 1 STU 1	ST 2,5 STU 2,5	ST 2,5 STU 2,5	P. 338
5-step transformer	TRE 0,4-2	TRE 0,4-2	TRE 0,4-2	TRE 0,6-2	TRE 0,6-2	TRE 1,6-2	TRE 1,6-2	P. 340
Follow-up relay	NRS 10	NRS 10	NRS 10	NRS 10	NRS 10	NRS 10	NRS 10	P. 343
Timer	ZS 4	ZS 4	ZS 4	ZS 4	ZS 4	ZS 4	ZS 4	P. 343
Thermostat	THR 10 TH 10 TH 16	THR 10 TH 10 TH 16	THR 10 TH 10 TH 16	THR 10 TH 10 TH 16	THR 10 TH 10 TH 16	THR 10 TH 10 TH 16	THR 10 TH 10 TH 16	P. 343, P. 344
Temperature control system	EAT 6 G/1 EAT 6 TG	EAT 6 G/1 EAT 6 TG	EAT 6 G/1 EAT 6 TG	EAT 6 G/1 EAT 6 TG	EAT 6 G/1 EAT 6 TG	EAT 6 G/1 EAT 6 TG	EAT 6 G/1 EAT 6 TG	P. 345
Hygrostat	HY 230 HY 230 I	HY 230 HY 230 I	HY 230 HY 230 I	HY 230 HY 230 I	HY 230 HY 230 I	HY 230 HY 230 I	HY 230 HY 230 I	P. 348

**Roof sockets for flat roofs
SO**

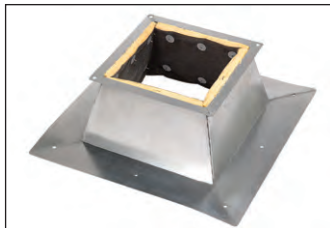

- Flat roof socket for assembly of roof fans.
- With non-flammable sound and heat insulation.

Dimensions [mm]

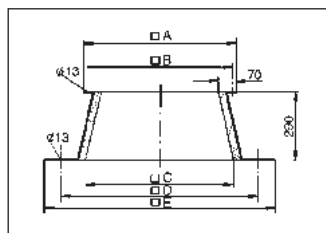

Common features

Housing material Sheet steel, galvanised

Article	Art. No.	Nominal size mm
SO 18	0093.0887	180
SO 22	0093.0358	224
SO 25	0093.0360	250
SO 30	0093.0361	300
SO 35	0093.0362	355
SO 40	0093.0363	400
SO 45	0093.0874	450
SO 50	0093.0364	500
SO 60	0093.0365	600

Article	A mm	B mm	C mm	D mm	E mm
SO 18	460	420	460	670	820
SO 22	500	460	500	710	860
SO 25	540	500	540	750	900
SO 30	610	570	610	820	970
SO 35	650	610	650	860	1,010
SO 40	690	650	690	900	1,050
SO 45	780	740	780	990	1,140
SO 50	840	800	840	1,050	1,200
SO 60	880	840	880	1,090	1,240

**Roof sockets for flat roofs, tiltable
SOK**

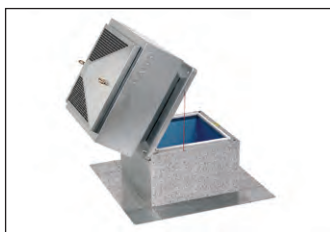

- Flat roof socket for assembly of roof fans.
- With tilting device to move the fan out of the way when working on the ventilation duct.
- With sound and heat insulation made of abrasion-resistant and non-flammable mineral fibre plates.
- Recommended accessories: SZ intermediate sockets.

Dimensions [mm]

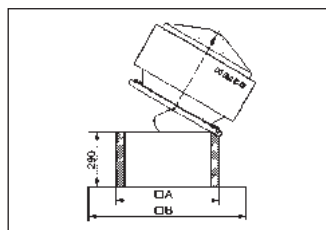

Common features

Housing material Sheet steel, galvanised

Article	Art. No.	Nominal size mm
SOK 18	0093.1030	180
SOK 22	0093.0991	225
SOK 25	0093.0992	250
SOK 31	0093.0993	315
SOK 35	0093.0994	355

Article	A mm	B mm
SOK 18	465	765
SOK 22	505	805
SOK 25	545	845
SOK 31	615	915
SOK 35	655	955

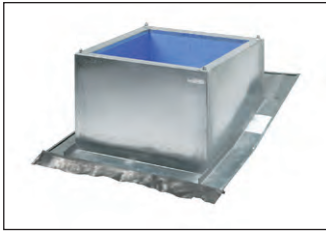
**Roof sockets for pitched roofs
 SDS**

Article	Art. No.	Nominal size mm
SDS 18	0093.1028	180
SDS 22	0093.0952	225
SDS 25	0093.0953	250
SDS 31	0093.0978	315
SDS 35	0093.0954	355
SDS 40	0093.0979	400
SDS 45	0093.0980	450
SDS 50	0093.1029	500

- Pitched roof socket for the installation of roof fans on tiled roofs.
- With sound and heat insulation made of abrasion-resistant and non-flammable mineral fibre plates.
- Only for use on tiled roofs.
- Standard models for up to 30° roof pitch.
- Varying socket heights and models for roof pitches of more than 30° are possible on request.
- Type of roof tiles and roof pitch must be given at the time of ordering.
- Note: Pitched roof sockets are produced to suit the customer's specifications. Therefore they cannot be returned.

Dimensions [mm]

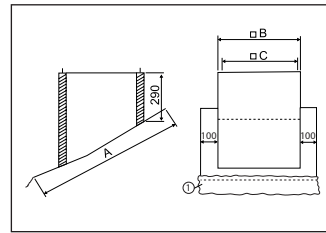

① Lead flashing

Article	A mm	B mm	C mm
SDS 18	765	465	420
SDS 22	805	505	460
SDS 25	845	545	500
SDS 31	915	615	570
SDS 35	955	655	610
SDS 40	955	695	650
SDS 45	1,095	785	740
SDS 50	1,145	845	800

Common features

Model	roof incline of up to 30°
Housing material	Sheet steel, galvanised

**Roof sockets for corrugated and trapezoidal roofs
 SOWT**

Article	Art. No.	Nominal size mm
SOWT 18	0093.1031	180
SOWT 22	0093.0984	225
SOWT 25	0093.0985	250
SOWT 31	0093.0986	315
SOWT 35	0093.0987	350
SOWT 40	0093.0988	400
SOWT 45	0093.0989	450
SOWT 50	0093.1032	500

- Pitched roof socket for assembly of roof fans.
- With sound and heat insulation made of abrasion-resistant and non-flammable mineral fibre plates.
- Standard models for up to 30° roof pitch.
- Varying socket heights and models for roof pitches of more than 30° are possible on request.
- For use on trapezoidal and corrugated roofs.
- Matching profile shape must be prepared by the customer.
- Profile sheet metal must be provided by the customer.
- Note: Corrugated and trapezoidal roof sockets are produced to the customer's specifications. Therefore they cannot be returned.

Dimensions [mm]

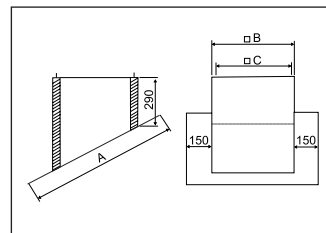

Article	A mm	B mm	C mm
SOWT 18	765	465	420
SOWT 22	805	505	460
SOWT 25	845	545	500
SOWT 31	915	615	570
SOWT 35	955	655	610
SOWT 40	955	695	650
SOWT 45	1,095	785	740
SOWT 50	1,145	845	800

Common features

Model	roof incline of up to 30°
Housing material	Sheet steel, galvanised

Further roof sockets on request.

**Socket sound absorbers
SD**

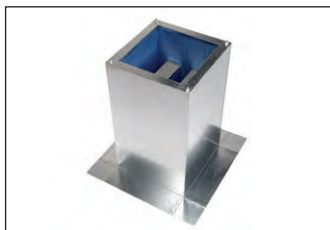

- Silencer for suction side sound insulation of roof fans.
- With silencing elements made of abrasion-resistant and non-flammable mineral fibre plates.
- Insertion loss in the octave band, see www.maico-fans.com.
- Recommended accessories: SZ intermediate sockets for connecting ducts.

Dimensions [mm]

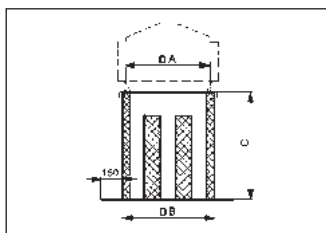

Common features

Housing material	Sheet steel, galvanised
Max. flow velocity	20 m/s

Article	Art. No.	Nominal size mm
SD 18	0092.0337	180
SD 22	0092.0338	225
SD 25	0092.0339	250
SD 31	0092.0340	315
SD 35	0092.0341	355
SD 40	0092.0342	400
SD 45	0092.0343	450
SD 50	0092.0344	500

Article	A mm	B mm	C mm
SD 18	420	465	850
SD 22	460	505	850
SD 25	500	545	850
SD 31	570	615	850
SD 35	610	655	850
SD 40	650	695	850
SD 45	740	785	850
SD 50	800	855	850

**Intermediate sockets
SZ**

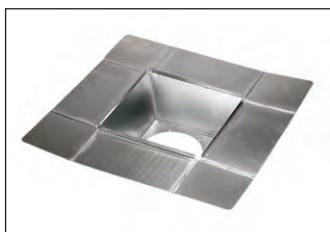

- Intermediate sockets for roof fans.
- For a connection between the SD socket sound absorber and the ventilation ducts that is economical in terms of air flow and easy to mount.
- For installation in flat roofs.

Dimensions [mm]

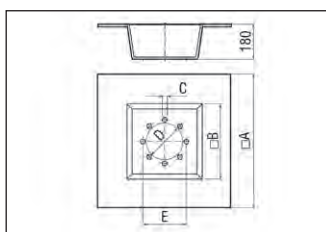

Common features

Housing material	Sheet steel, galvanised
Installation site	Roof
Max. ambient temperature	100 °C

Article	Art. No.	Nominal size mm
SZ 18	0092.0286	180
SZ 22	0092.0287	225
SZ 25	0092.0288	250
SZ 31	0092.0289	315
SZ 35	0092.0290	350
SZ 40	0092.0291	400
SZ 45	0092.0292	450

Article	A mm	B mm	C mm	D mm	E mm
SZ 18	770	370	7	190	213
SZ 22	800	400	7	238	259
SZ 25	840	440	7	262	286
SZ 31	910	510	9.5	312	356
SZ 35	950	550	9.5	362	395
SZ 40	990	590	9.5	412	438
SZ 45	1,080	680	9.5	457	487

**Suction nozzles
AD**

- Suction nozzle for turbulence-reduced air intake.

Dimensions [mm]

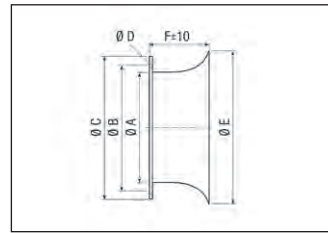
Common features

Material	Sheet steel, galvanised
Air direction	Ventilation and air extraction

Article	Art. No.	Nominal size mm
AD 20	0180.0628	200
AD 25	0180.0620	250
AD 30	0180.0621	300
AD 35	0180.0622	350
AD 40	0180.0623	400
AD 45	0180.0624	450
AD 50	0180.0625	500
AD 56	0180.0626	560
AD 60	0180.0627	600

Article	A	B	C	D	E	F
	mm	mm	mm	mm	mm	mm
AD 20	213	235	254	8	265	110
AD 25	263	286	314	7.5	335	110
AD 30	313	356	380	10	385	100
AD 35	363	395	420	10	435	100
AD 40	413	438	460	10	485	100
AD 45	458	487	510	10	535	100
AD 50	513	541	565	10	585	100
AD 56	570	629	664	14	657	90
AD 60	613	676	710	14	700	90

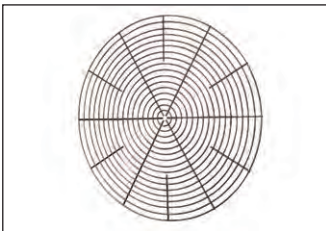
**Protective grilles, metal
SG**

- Protective grille for fans in accordance with DIN EN ISO 13857.
- Suitable for fans with duct connections.
- Can be fitted on the inlet or pressure side.
- Made of antistatic material, for use in areas subject to explosion hazards.

Dimensions [mm]

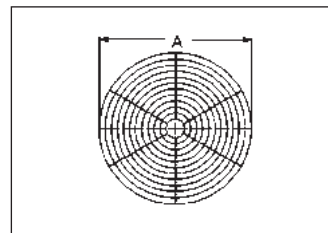

Common features

Material	Wire, chromated
Air direction	Ventilation and air extraction

Article	Art. No.	Nominal size mm
SG 20	0150.0114	200
SG 25	0150.0115	250
SG 30	0150.0116	300
SG 35	0150.0117	350
SG 40	0150.0118	400
SG 45	0150.0119	450
SG 50	0150.0120	500
SG 56	0150.0121	560
SG 60	0150.0122	600

Article	A
	mm
SG 20	249
SG 25	297
SG 30	369
SG 35	410
SG 40	455
SG 45	500
SG 50	558
SG 56	646
SG 60	698

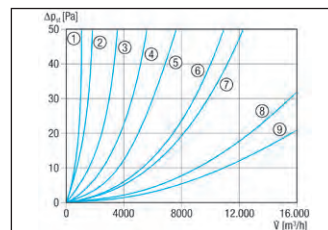
Pressure losses



- ① SG 20
- ② SG 25
- ③ SG 30
- ④ SG 35
- ⑤ SG 40
- ⑥ SG 45
- ⑦ SG 50
- ⑧ SG 56
- ⑨ SG 60

**Protective grilles,
synthetic material
SGK**

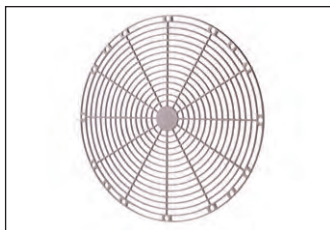

- Protective grille for fans in accordance with DIN EN ISO 13857.
- Suitable for EZQ / DZQ, EZR / DZR and EZD / DZD.
- Can be fitted on the inlet or pressure side.
- Do not use in areas subject to explosions.

Dimensions [mm]

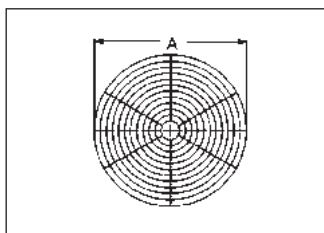

Common features

Material	Synthetic material
Max. ambient temperature	65 °C
Air direction	Ventilation and air extraction

Article	Art. No.	Nominal size mm
SGK 20	0059.0161	200
SGK 25	0059.0162	250
SGK 30	0059.0163	300
SGK 35	0059.0164	350
SGK 40	0059.0165	400

Article	A mm
SGK 20	249
SGK 25	297
SGK 30	369
SGK 35	410
SGK 40	455

Pressure losses

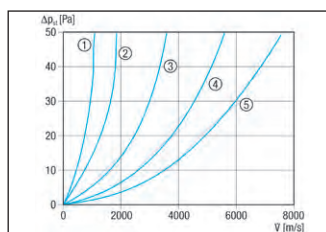

- ① SGK 20
- ② SGK 25
- ③ SGK 30
- ④ SGK 35
- ⑤ SGK 40

**Counter flanges
GF**



- Counter flange for the assembly of fans to ventilation ducts.

Dimensions [mm]

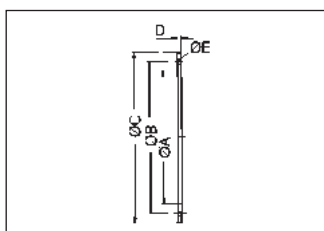

Common features

Material	Steel, galvanised
----------	-------------------

Article	Art. No.	Nominal size mm
GF 20	0056.0002	200
GF 25	0056.0003	250
GF 30	0056.0004	300
GF 35	0056.0005	350
GF 40	0056.0006	400
GF 45	0056.0007	450
GF 50	0056.0008	500
GF 56	0056.0010	560
GF 60	0056.0009	600

Article	A mm	B mm	C mm	D mm	E mm
GF 20	213	235	254	5	7
GF 25	263	286	304	5	7
GF 30	313	356	380	6	9.5
GF 35	363	395	420	6	9.5
GF 40	413	438	460	6	9.5
GF 45	458	487	510	6	9.5
GF 50	513	514	565	6	9.5
GF 56	570	629	664	6	9.5
GF 60	613	674	710	6	9.5

**Counter sockets
GS**



- Counter socket for fitting flexible cuffs on ventilation ducts.
- Suited to assembly of folded spiral-seams duct in combination with EL / EL Ex flexible cuffs only.

Dimensions [mm]

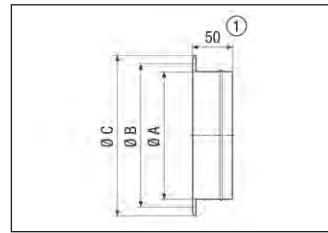

① GS 56: 55 mm

Common features

Material Sheet steel, galvanised

Article	Art. No.	Suitable for nominal size cuffs mm
GS 20	0055.0168	200
GS 25	0055.0169	250
GS 30	0055.0170	300
GS 35	0055.0171	350
GS 40	0055.0172	400
GS 45	0055.0173	450
GS 50	0055.0174	500
GS 56	0055.0176	560
GS 60	0055.0175	600

Article	A mm	B mm	C mm	D mm
GS 20	210	235	254	8
GS 25	263	286	304	8
GS 30	313	356	380	10
GS 35	363	395	420	10
GS 40	413	438	460	10
GS 45	458	487	512	10
GS 50	513	541	565	10
GS 56	570	629	664	14
GS 60	613	674	710	14

**Flexible cuffs
EL/EL Ex**



- Flexible cuffs for sound and vibration damped assembly of duct fans.
- With 2 tightening straps.
- EL ...: Made of plastic.
- EL .. Ex: Made of antistatic material, for use in areas subject to explosion hazards.

Dimensions [mm]

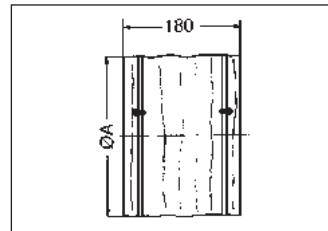

Common features

Max. ambient temperature 80 °C

Article	Art. No.	Nominal size mm
EL 20	0092.0154	200
EL 25	0092.0088	250
EL 30	0092.0089	300
EL 35	0092.0090	350
EL 40	0092.0091	400
EL 45	0092.0155	450
EL 50	0092.0092	500
EL 56	0092.0150	560
EL 60	0092.0093	600
EL 20 Ex	0092.0231	200
EL 25 Ex	0092.0232	250
EL 30 Ex	0092.0233	300
EL 35 Ex	0092.0234	350
EL 40 Ex	0092.0235	400
EL 45 Ex	0092.0236	450
EL 50 Ex	0092.0237	500
EL 60 Ex	0092.0238	600

Article	A mm
EL 20	213
EL 25	263
EL 30	313
EL 35	363
EL 40	413
EL 45	458
EL 50	513
EL 56	570
EL 60	613
EL 20 Ex	213
EL 25 Ex	263
EL 30 Ex	313
EL 35 Ex	363
EL 40 Ex	413
EL 45 Ex	458
EL 50 Ex	513
EL 60 Ex	613

**Flexible couplings
ELA/ELA Ex**



- Flexible couplings for the sound and vibration damped connection of ventilation ducts.
- With flanges fitted on the fan side.
- With push-in couplings on the duct side.
- ELA ...: Made of plastic.
- ELA .. Ex: Made of antistatic material, for use in areas subject to explosion hazards.

Dimensions [mm]

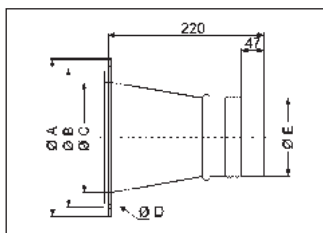

Common features

Flange material Steel, galvanised

Article	Art. No.	Nominal size mm
ELA 18	0092.0283	180
ELA 20	0092.0265	200
ELA 22	0092.0282	224
ELA 25	0092.0266	250
ELA 30	0092.0267	300
ELA 31	0092.0284	315
ELA 35	0092.0268	355
ELA 40	0092.0269	400
ELA 45	0092.0270	450
ELA 50	0092.0271	500
ELA 56	0092.0272	560
ELA 60	0092.0273	600
ELA 20 Ex	0092.0274	200
ELA 25 Ex	0092.0275	250
ELA 30 Ex	0092.0276	300
ELA 31 Ex	0092.0285	315
ELA 35 Ex	0092.0277	350
ELA 40 Ex	0092.0278	400
ELA 45 Ex	0092.0279	450
ELA 50 Ex	0092.0280	500
ELA 60 Ex	0092.0281	600

Article	A mm	B mm	C mm	D mm	E mm
ELA 18	232	213	190	7	178
ELA 20	254	235	212	7	198
ELA 22	280	259	238	7	222
ELA 25	304	286	262	7	247
ELA 30	380	356	312	9.5	297
ELA 31	380	356	312	9.5	312
ELA 35	420	395	362	9.5	352
ELA 40	460	438	412	9.5	397
ELA 45	510	487	457	9.5	447
ELA 50	565	541	512	9.5	497
ELA 56	664	629	569	14	557
ELA 60	710	674	612	14	597
ELA 20 Ex	254	235	212	7	198
ELA 25 Ex	304	286	262	7	247
ELA 30 Ex	380	356	312	9.5	297
ELA 31 Ex	380	356	312	9.5	312
ELA 35 Ex	420	395	362	9.5	347
ELA 40 Ex	460	438	412	9.5	397
ELA 45 Ex	510	487	457	9.5	447
ELA 50 Ex	565	541	512	9.5	497
ELA 60 Ex	710	674	612	14	597

**Control shutters
JRE**



- Blind control shutters for automatic activation.
- Must be combined with additional MS 8 or MS 8 P servomotors (servomotor is not included in the scope of delivery).
- Do not use in areas subject to explosions.

Installation instructions

- Ensure access to the servomotor.

Article	Art. No.	Nominal size mm
JRE 25	0151.0390	250
JRE 30	0151.0391	300
JRE 35	0151.0392	350
JRE 40	0151.0393	400
JRE 50	0151.0394	500
JRE 60	0151.0395	600

Dimensions [mm]

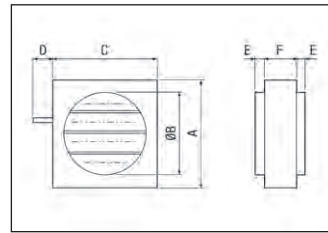

Article	A mm	B mm	C mm	D mm	E mm	F mm
JRE 25	308	250	305	58	41	69
JRE 30	358	300	355	58	41	69
JRE 35	408	350	405	58	41	69
JRE 40	458	400	455	58	55	69
JRE 50	558	500	555	58	55	69
JRE 60	658	600	655	58	55	69

Common features

Material	Sheet steel, galvanised
Installation site	Duct
Air direction	Ventilation and air extraction
Type of shutter	electrical

Pressure losses

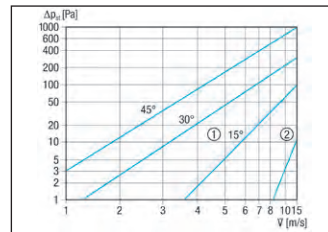

- ① Opening angle of lamella
- ② open

**Servo motors
MS 8**



Article	Art. No.
MS 8	0157.0760
MS 8 P	0157.0761

- Servomotors for opening and closing the RKP duct shutter and JRE blind control shutter.
- With limiting strap for torsion safety.
- Can be combined with drive axis up to 20 mm diameter or 16 mm square.
- Maximum turning angle: 90°.
- Turning angle limit adjustable in 5° steps.
- With two-point control for "Open" and "Closed" settings.
- Drive axis can be rotated to the right or left.
- MS 8 P: With 2 additional auxiliary switches.
- Not suitable for use in areas subject to explosion hazards.

Installation instruction















- With pushbutton for release of the gear, e.g. for manual setting of the shutter.
- If PG 11 screws are used: IP 54 degree of protection.
- Note: US 16 T universal contactor or customer-provided relay required for speed control with phase angles.
- 4-core mains cable is needed.

Common features

U _{nom}	230 V
f _{nom}	50 Hz/60 Hz
Degree of protection	IP 44
Maximum load (inductive load)	2 A
Maximum load (ohmic load)	10 A
Housing material	Synthetic material, weather and UV resistant
Colour	Blue
Width	100 mm
Height	180 mm
Depth	65 mm

Accessories



External shutters / external grilles / roof cowls / wall connections		Page 296
Outside air openings		Page 308
Volumetric flow limiters		Page 310
Internal shutters / internal grilles		Page 311
Air grilles / supply and exhaust air valves		Page 314
Sound absorbers		Page 320
Air heaters		Page 323
Air filters		Page 327
Switches		Page 334
Speed controllers / frequency converters / step transformers		Page 338
Time delay switches / timers		Page 342
Thermostats / temperature control systems		Page 343
Sensors		Page 346
Room air controls		Page 350
Radio switch		Page 350

External shutters



**Shutters
AP 100/120**



- Airstream-operated shutters for air extraction.
- Exterior wall connection when using wall sleeve WH 100 or WH 120.
- AP 100 B: Shutter in brown.
- With covered screw holes.
- Sealing tape included in the scope of delivery.
- Accessories: FG fly screen can be used.

Dimensions [mm]

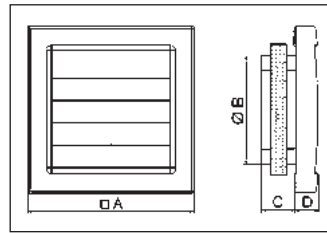

Article	A mm	B mm	C mm	D mm
AP 100	150	98	29	21
AP 100 B	150	98	29	21
AP 120	172	113	30	23

Common features

Loss of pressure	10 Pa
Material	Synthetic material, weather and UV resistant
Max. ambient temperature	60 °C
Air direction	Air extraction
Type of shutter	Airstream-operated opening/closing

Article	Art. No.	Nom- inal size mm	Colour
AP 100	0059.1058	100	Traffic white, similar to RAL 9016
AP 100 B	0059.0957	100	Brown
AP 120	0059.0950	125	Traffic white, similar to RAL 9016

**Fly screens
FG**

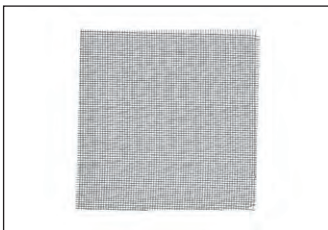

- Fly screen for installation in AP ... or SG ...

Article	Width mm	Height mm	Depth mm
FG 100	120	120	2
FG 120	140	140	2

Common features

Material	Metal
----------	-------

Article	Art. No.	Nominal size mm
FG 100	0093.0922	100
FG 120	0093.0924	120

**Shutter
AP 150**



- Shutter for air extraction.
- Exterior wall connection when using WH 150 wall sleeve.
- Sealing tape included in the scope of delivery.

Dimensions [mm]

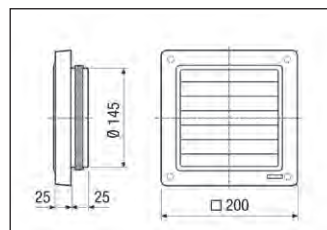

Features

Nominal size	150 mm
Loss of pressure	10 Pa
Material	Synthetic material, weather and UV resistant
Colour	Traffic white, similar to RAL 9016
Max. ambient temperature	60 °C
Air direction	Air extraction
Type of shutter	Airstream-operated opening/closing

Article	Art. No.
AP 150	0059.0952

**Shutters
AS**



- Shutters for air extraction.
- With galvanised protective grille.
- From nominal size 35 with centre bridge for increasing the stability of the shutters.

Recommended accessories:
ZVR connection frames for mounting the AS and RS shutters to the fan rather than the wall.

Article	Art. No.	Nominal size mm
AS 20	0151.0330	200
AS 25	0151.0331	255
AS 30	0151.0332	300
AS 35	0151.0333	355
AS 40	0151.0334	400
AS 45	0151.0335	450
AS 50	0151.0336	500
AS 60	0151.0337	600

Dimensions [mm]

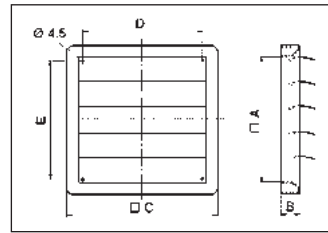

Article	A mm	B mm	C mm	D mm	E mm
AS 20	200	39	260	197	182
AS 25	255	40	314	250	234
AS 30	307	40	366	300	286
AS 35	360	40	420	355	338
AS 40	412	40	472	405	390
AS 45	465	41	526	460	442
AS 50	517	41	578	510	494
AS 60	622	42	684	615	598

Common features

Material	Synthetic material, weather and UV resistant
Colour	Traffic white, similar to RAL 9016
Installation site	Wall
Lamella colour	Silver grey
Max. ambient temperature	60 °C
Air direction	Air extraction
Type of shutter	Airstream-operated opening/closing

Pressure losses

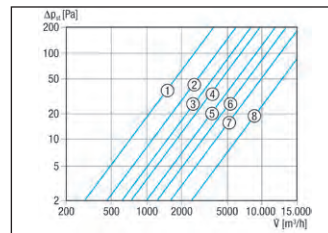

- ① AS 20
- ② AS 25
- ③ AS 30
- ④ AS 35
- ⑤ AS 40
- ⑥ AS 45
- ⑦ AS 50
- ⑧ AS 60

**Connection frames
ZVR**



- Connection frames for mounting the AS and RS shutters to the fan models of EZQ, EZS, DZQ and DZS series.
- For fitting in thin walls.

Article	Art. No.	Nominal size mm
ZVR 20	0093.0191	200
ZVR 25	0093.0192	250
ZVR 30	0093.0193	300
ZVR 35	0093.0194	350
ZVR 40	0093.0195	400
ZVR 45	0093.0196	450
ZVR 50	0093.0197	500
ZVR 56	0093.0198	560
ZVR 60	0093.0199	600

Dimensions [mm]

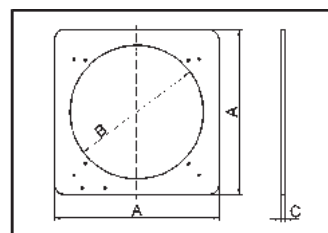

Article	A mm	B mm	C mm
ZVR 20	260	210	1
ZVR 25	314	260	1
ZVR 30	366	310	1
ZVR 35	420	360	1
ZVR 40	472	410	1
ZVR 45	526	456	1
ZVR 50	578	510	2
ZVR 56	684	568	2
ZVR 60	684	610	2

Common features

Material	Sheet steel, galvanised
Installation site	Thin wall

External shutters



Shutters ARP



- Shutters for air extraction.
- With individually moving lamella, fitted using reinforced bushing.
- With galvanised protective grille on the inflow side.
- Two-part ARP 71.
- Three-part ARP 80 and ARP 100.

Dimensions [mm]

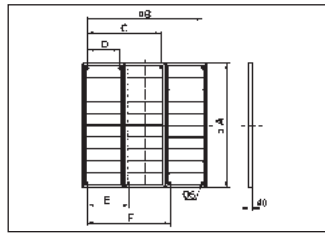

Article	A mm	B mm	C mm	D mm	E mm	F mm
ARP 71	890	818	-	-	-	-
ARP 80	940	868	555	241	313	627
ARP 100	1,140	1,068	688	308	380	760

Common features

Material	Synthetic material, weather and UV resistant
Colour	Silver grey
Installation site	Wall
Max. ambient temperature	60 °C
Air direction	Air extraction
Type of shutter	Airstream-operated opening/closing

Article	Art. No.	Nominal size mm
ARP 71	0151.0082	710
ARP 80	0151.0081	800
ARP 100	0151.0080	1,000

Shutters, electric MK/BK



- Electrical shutter for weather protection and prevention of cold air entry when fan is switched off.
- MK with gear motor: Rated power 3 W, nominal current 0.015 A.
- BK with bimetal cap: Rated power 25 W, rated current 0.01 A, start-up current 1.8 A - 1s. Speed control only with STU 2,5 / ST 2,5 speed controller.
- Installation in accordance with protection class II (without protective-conductor terminal).
- Opens and closes when the fan is switched on and off.
- MK needs 4-core mains cable.
- BK needs 3-core mains cable.
- Special models with limit switch can be supplied on request. Limit switch is activated when the shutter is completely open.

Dimensions [mm]

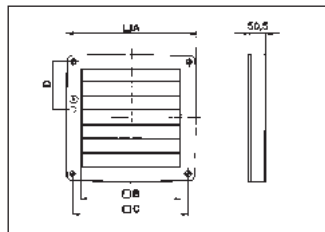

① Cable entry

Article	A mm	B mm	C mm	D mm
MK 20	325	218	275	83
MK 25	370	262	320	105.5
MK 31	430	320	380	135.5
BK 20	325	218	275	83
BK 25	370	262	320	105.5
BK 31	430	320	380	135.5

Common features

U _{nom}	230 V
Degree of protection	IP 55
Loss of pressure	11 Pa
Material	Synthetic material
Colour	Traffic white, similar to RAL 9016
Installation site	Wall
Lamella colour	Silver grey
Max. ambient temperature	40 °C
Type of shutter	electrical

Article	Art. No.	Nominal size mm	Drive
MK 20	0093.0906	200	Gear
MK 25	0093.0907	250	Gear
MK 31	0093.0908	315	Gear
BK 20	0093.0900	200	Bimetal
BK 25	0093.0901	250	Bimetal
BK 31	0093.0902	315	Bimetal

**Shutters, manual
RS**



- Shutters for air extraction and ventilation.
- Lamella can be operated manually or with an additional MS 2 servomotor.
- From nominal size 35 with centre bridge for increasing the stability of the shutters.
- With pulley, 2.5 m pull cord and pull-cord clip.
- With galvanised protective grille.
- Recommended accessories: ZVR connection frames for mounting the AS and RS shutters to the fan rather than the wall.

Article	Art. No.	Nominal size mm
RS 20	0151.0338	200
RS 25	0151.0339	255
RS 30	0151.0340	300
RS 35	0151.0341	355
RS 40	0151.0342	400
RS 45	0151.0343	450
RS 50	0151.0344	500
RS 60	0151.0345	600

Dimensions [mm]

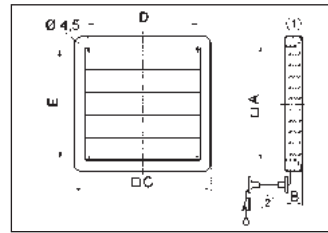

- ① Manually adjustable
- ② Pulley for pull cord

Article	A mm	B mm	C mm	D mm	E mm
RS 20	200	39	260	197	182
RS 25	255	40	314	250	234
RS 30	307	40	366	300	286
RS 35	360	40	420	355	338
RS 40	412	41	472	405	390
RS 45	465	41	526	460	442
RS 50	517	42	578	510	494
RS 60	622	42	684	615	598

Common features

Material	Synthetic material, weather and UV resistant
Colour	Traffic white, similar to RAL 9016
Installation site	Wall
Lamella colour	Silver grey
Max. ambient temperature	60 °C
Air direction	Ventilation and air extraction
Type of shutter	electrical/manual

Pressure losses

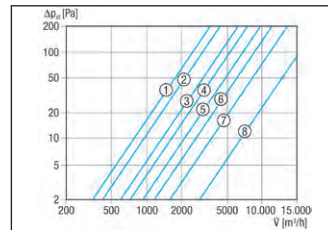

- ① RS 20
- ② RS 25
- ③ RS 30
- ④ RS 35
- ⑤ RS 40
- ⑥ RS 45
- ⑦ RS 50
- ⑧ RS 60

**Connection frames
ZVR**



- Connection frames for mounting the AS and RS shutters to the fan models of EZQ, EZS, DZQ and DZS series.
- For fitting in thin walls.

Article	Art. No.	Nominal size mm
ZVR 20	0093.0191	200
ZVR 25	0093.0192	250
ZVR 30	0093.0193	300
ZVR 35	0093.0194	350
ZVR 40	0093.0195	400
ZVR 45	0093.0196	450
ZVR 50	0093.0197	500
ZVR 56	0093.0198	560
ZVR 60	0093.0199	600

Dimensions [mm]

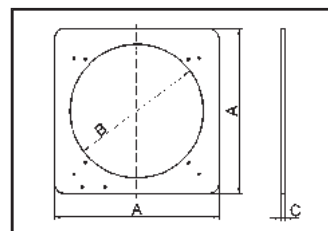

Article	A mm	B mm	C mm
ZVR 20	260	210	1
ZVR 25	314	260	1
ZVR 30	366	310	1
ZVR 35	420	360	1
ZVR 40	472	410	1
ZVR 45	526	456	1
ZVR 50	578	510	2
ZVR 56	684	568	2
ZVR 60	684	610	2

Common features

Material	Sheet steel, galvanised
Installation site	Thin wall

External shutters



Servomotor
MS 2



- Servomotor for opening and closing the RS shutters.
- 4-core mains cable is needed.

Article	Art. No.
MS 2	0093.0403

Dimensions [mm]

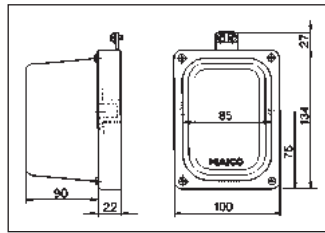

Features

U_{nom}	230 V
Degree of protection	IP 65
I_{max}	0.02 A
Torque	2 Nm
Housing material	Synthetic material, weather and UV resistant
Colour	Pearl white, similar to RAL 1013
Max. ambient temperature	40 °C
Width	100 mm
Height	161 mm
Depth	112 mm

Control shutters
JRE



- Blind control shutters for automatic activation.
- Must be combined with additional MS 8 or MS 8 P servomotors (servomotor is not included in the scope of delivery).
- Do not use in areas subject to explosions.

Installation instructions

- Ensure access to the servomotor.

Dimensions [mm]

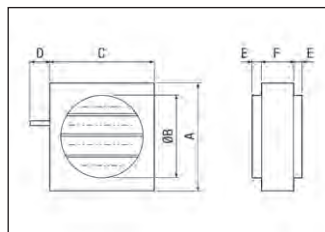

Common features

Material	Sheet steel, galvanised
Installation site	Duct
Air direction	Ventilation and air extraction
Type of shutter	electrical

Article	Art. No.	Nominal size mm
JRE 25	0151.0390	250
JRE 30	0151.0391	300
JRE 35	0151.0392	350
JRE 40	0151.0393	400
JRE 50	0151.0394	500
JRE 60	0151.0395	600

Article	A	B	C	D	E	F
	mm	mm	mm	mm	mm	mm
JRE 25	308	250	305	58	41	69
JRE 30	358	300	355	58	41	69
JRE 35	408	350	405	58	41	69
JRE 40	458	400	455	58	55	69
JRE 50	558	500	555	58	55	69
JRE 60	658	600	655	58	55	69

Pressure losses

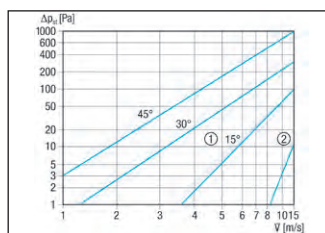

- ① Opening angle of lamella
- ② open

**Automatic backflow preventers
AVM**



- Horizontal and vertical mounting is possible. Air flow direction for a vertical installation is from the bottom flowing upwards.
- With 2 opposing shutter sections made of aluminium.
- With wrap-around seal.
- The backflow preventers are opened in the air flow and closed by spring force.

Article	Art. No.	Nominal size mm
AVM 10	0093.0002	100
AVM 12	0093.0003	125
AVM 15	0093.0004	150
AVM 16	0093.0008	160
AVM 20	0093.0006	200
AVM 25	0093.0007	250
AVM 31	0093.0009	315
AVM 35	0093.0012	355
AVM 40	0093.0013	400

Dimensions [mm]

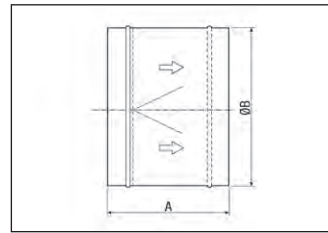

Article	A mm	B mm
AVM 10	88	98
AVM 12	88	124
AVM 15	88	149
AVM 16	88	158
AVM 20	88	198
AVM 25	128	248
AVM 31	128	313
AVM 35	198	353
AVM 40	198	398

Common features

Material	Sheet steel, galvanised
Air direction	Ventilation or air extraction
Type of shutter	Airstream-operated opening/closing

Pressure losses

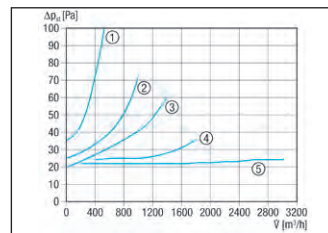

- ① AVM 10
- ② AVM 12
- ③ AVM 15
- ④ AVM 16
- ⑤ AVM 20, AVM 25, AVM 31, AVM 35, AVM 40

**Channel shutters
AKP**

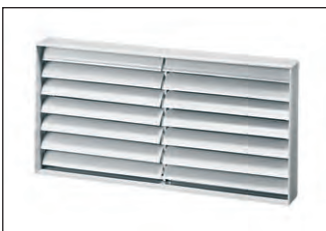

- Shutters for air extraction.
- With galvanised protective grille.

Article	Art. No.	Channel width dimension mm	Channel height dimension mm
AKP 22	0151.0096	500	250
AKP 25	0151.0097	500	300
AKP 28	0151.0098	600	300
AKP 31	0151.0099	600	350
AKP 35	0151.0100	700	400

Dimensions [mm]

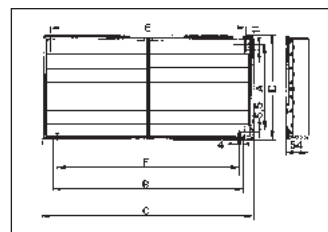

Article	A mm	B mm	C mm	D mm	E mm	F mm
AKP 22	290	540	585	335	551	517
AKP 25	340	540	585	385	551	517
AKP 28	340	640	685	385	651	617
AKP 31	390	640	685	435	651	617
AKP 35	440	740	785	485	751	717

Common features

Loss of pressure	10 Pa
Material	Synthetic material, weather and UV resistant
Colour	Light grey
Installation site	Channel
Max. ambient temperature	60 °C
Air direction	Air extraction
Type of shutter	Airstream-operated opening/closing

External shutters



Channel shutters
RKP



- With counter-rotating, hollow body lamella, which can be adjusted together over 15 x 15 mm square.
- With U-shaped frame and flange holes on both sides.
- With position indicator - Open/ Closed.
- Must be combined with additional MS 8 or MS 8 P servomotors (servomotor is not included in the delivery).

Dimensions [mm]

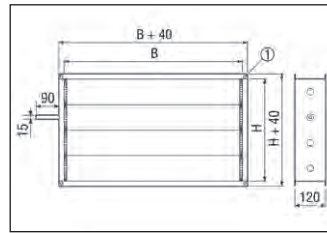

① Slot, 9 x 12 mm

Common features

Material	Sheet steel, galvanised
Installation site	Channel
Air direction	Ventilation and air extraction
Type of shutter	electrical

Article	Art. No.	Channel width dimension mm	Channel height dimension mm
RKP 22	0151.0235	500	250
RKP 25	0151.0236	500	300
RKP 28	0151.0237	600	300
RKP 31	0151.0238	600	350
RKP 35	0151.0239	700	400
RKP 50	0151.0240	800	500
RKP 56	0151.0241	1,000	500

Article	B mm	H mm
RKP 22	500	250
RKP 25	500	300
RKP 28	600	300
RKP 31	600	350
RKP 35	700	400
RKP 50	800	500
RKP 56	1,000	500

Pressure losses

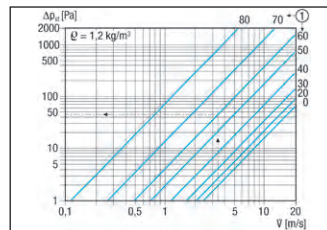

① Angle of lamella in degrees

Servo motors
MS 8



Article	Art. No.
MS 8	0157.0760
MS 8 P	0157.0761

- Servomotors for opening and closing the RKP duct shutter and JRE blind control shutter.
- With limiting strap for torsion safety.
- Can be combined with drive axis up to 20 mm diameter or 16 mm square.
- Maximum turning angle: 90°.
- Turning angle limit adjustable in 5° steps.
- With two-point control for "Open" and "Closed" settings.
- Drive axis can be rotated to the right or left.
- MS 8 P: With 2 additional auxiliary switches.
- Not suitable for use in areas subject to explosion hazards.

Installation instruction

- With pushbutton for release of the gear, e.g. for manual setting of the shutter.
- If PG 11 screws are used: IP 54 degree of protection.
- Note: US 16 T universal contactor or customer-provided relay required for speed control with phase angles.
- 4-core mains cable is needed.

Common features

U _{nom}	230 V
f _{nom}	50 Hz/60 Hz
Degree of protection	IP 44
Maximum load (inductive load)	2 A
Maximum load (ohmic load)	10 A
Housing material	Synthetic material, weather and UV resistant
Colour	Blue
Width	100 mm
Height	180 mm
Depth	65 mm

**External grilles
SG 100/120**



- External grille for air extraction and ventilation.
- Exterior wall connection when using wall sleeve WH 100 or WH 120.
- SG 100 B: External grille in brown.
- With covered screw holes.
- Sealing tape included in the scope of delivery.
- Replacement air filter for SG 120: SF 120.
- FG fly screen accessory can be used.

Dimensions [mm]

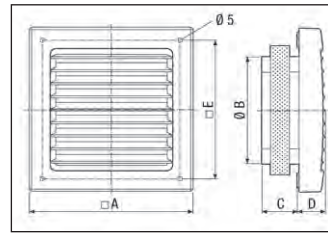

Article	A	B	C	D	E
	mm	mm	mm	mm	mm
SG 100	150	98	29	22.5	130
SG 100 B	150	98	29	22.5	130
SG 120	172	118	30	23	152

Common features

Material	Synthetic material, weather and UV resistant
Installation site	Wall
Max. ambient temperature	60 °C
Air direction	Ventilation and air extraction

Article	Art. No.	Nominal size mm	Colour
SG 100	0059.1054	100	Traffic white, similar to RAL 9016
SG 100 B	0059.0958	100	Brown
SG 120	0059.0951	125	Traffic white, similar to RAL 9016

**Fly screens
FG**

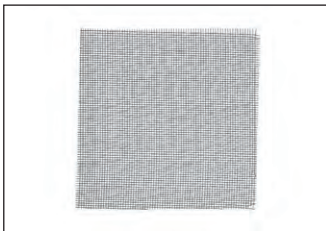

- Fly screen for installation in AP ... or SG ...

Article	Width mm	Height mm	Depth mm
FG 100	120	120	2
FG 120	140	140	2

Common features

Material	Metal
----------	-------

Article	Art. No.	Nominal size mm
FG 100	0093.0922	100
FG 120	0093.0924	120

**External grille
SG 15**



- External grille for air extraction and ventilation.
- Exterior wall connection when using WH 150 wall sleeve.
- With galvanised protective grille.
- Sealing tape included in the scope of delivery.

Dimensions [mm]

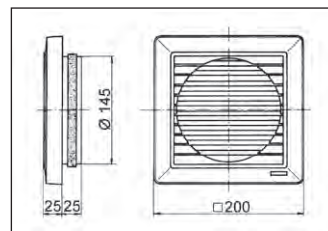

Features

Nominal size	150 mm
Material	Synthetic material, weather and UV resistant
Colour	Traffic white, similar to RAL 9016
Installation site	Wall
Max. ambient temperature	60 °C
Air direction	Ventilation and air extraction

Article	Art. No.
SG 15	0059.0904

External grilles



External grilles
MGR/MGE 80/125

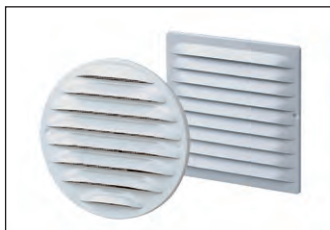

- MGR: External grille for covering round ventilation openings.
- MGE: External grille for covering square ventilation openings.
- With insect grille and spring-holder.
- For duct diameters from 80 mm to 125 mm.

Dimensions [mm] MGR

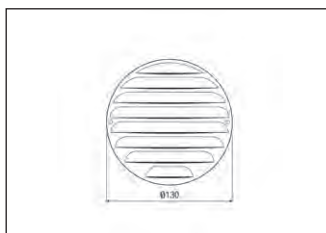

Dimensions [mm] MGE



Common features

Air direction Air extraction

Article	Art. No.	Model	Material
MGR 80/125 alu	0078.0033	round	Aluminium
MGR 80/125 V2A	0078.0034	round	Stainless steel
MGR 80/125 white	0078.0070	round	Metal
MGE 80/125 alu	0078.0030	square	Aluminium
MGE 80/125 V2A	0078.0031	square	Stainless steel
MGE 80/125 white	0078.0069	square	Metal

External grilles
MGE/MGR 160



- Weather protection grille for Ventilation and air extraction constructed to very high quality standard.
- MGR 160 alu: for covering round ventilation openings.
- MGE 160 alu: for covering square ventilation openings.
- With angled lamella and bird protection grille.
- With DN 160 socket for direct connection to ventilation ducts.
- MGE 160 alu has a round connection socket with rubber seal.

Dimensions [mm] MGR

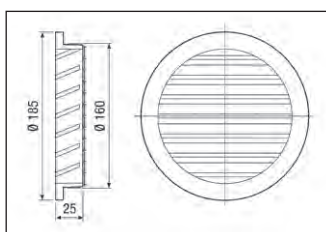

Dimensions [mm] MGE

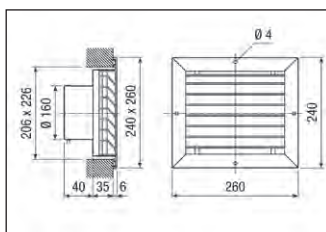

Common features

Nominal size 160 mm
Air direction Ventilation and air extraction

Article	Art. No.	Model	Material	Open cross section cm ²
MGR 160 alu	0078.0036	round	Cast aluminium	120
MGE 160 alu	0078.0037	square	Aluminium	180

Stainless steel cowls
LH-V2A



- Cowl for Ventilation and air extraction.
- For connecting to exhaust air ducts, extraction hoods, tumble dryers, etc.
- With connection socket and spring clamp for simple installation.
- With bird protection grille.
- No lip seal on socket and no condensation run-off catcher.
- If the cowl is used as outgoing air device, the customer must take action to ensure that any condensation produced does not drain onto the building facade.

Dimensions [mm]

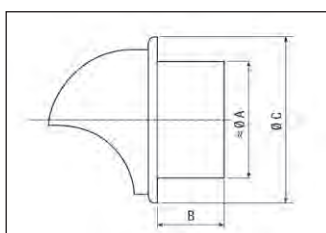

Common features

Material Stainless steel
Colour Stainless steel, brushed
Installation site Outside wall
Air direction Ventilation and air extraction

Article	Art. No.	Nominal size mm	Open cross section cm ²
LH-V2A 10	0151.0377	100	63
LH-V2A 12	0151.0378	125	98
LH-V2A 15	0151.0379	150	146
LH-V2A 16	0151.0380	160	172

Article	A mm	B mm	C mm
LH-V2A 10	100	45	150
LH-V2A 12	125	45	190
LH-V2A 15	150	52	212
LH-V2A 16	160	62	212

**External grilles
MLA/MLZ**



- External grille for air extraction and ventilation.
- With fixed rain-repellent weather protection lamella.
- With protective grille and installation frame on the rear side.

Dimensions [mm]

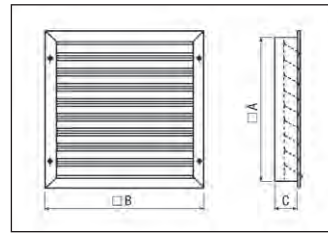

Common features

Max. flow velocity	4 m/s
Installation site	Wall
Air direction	Ventilation and air extraction

Article	Art. No.	Nominal size mm	Material	Open cross section cm ²
MLA 20	0151.0111	200	Aluminium	275
MLA 25	0151.0112	250	Aluminium	414
MLA 30	0151.0113	300	Aluminium	580
MLA 35	0151.0114	350	Aluminium	775
MLA 40	0151.0115	400	Aluminium	997
MLA 50	0151.0116	500	Aluminium	1,526
MLZ 20	0151.0101	200	Sheet steel, galvanised	275
MLZ 25	0151.0102	250	Sheet steel, galvanised	414
MLZ 30	0151.0103	300	Sheet steel, galvanised	580
MLZ 35	0151.0104	350	Sheet steel, galvanised	775
MLZ 40	0151.0105	400	Sheet steel, galvanised	997
MLZ 50	0151.0106	500	Sheet steel, galvanised	1,526

Article	A mm	B mm	C mm
MLA 20	230	252	50
MLA 25	280	302	50
MLA 30	330	352	50
MLA 35	380	402	45
MLA 40	430	452	45
MLA 50	530	552	45
MLZ 20	230	252	45
MLZ 25	280	302	45
MLZ 30	330	352	45
MLZ 35	380	402	45
MLZ 40	430	452	45
MLZ 50	530	552	45

Pressure losses

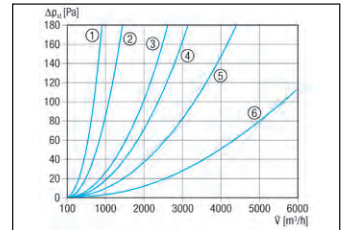

- ① MLA 20, MLZ 20
- ② MLA 25, MLZ 25
- ③ MLA 30, MLZ 30
- ④ MLA 35, MLZ 35
- ⑤ MLA 40, MLZ 40
- ⑥ MLA 50, MLZ 50

**External grilles
LZP**



- External grille for air extraction and ventilation.
- With fixed rain-repellent weather protection lamella.
- With frame for mounting in masonry walls.
- Protective grille in accordance with DIN EN ISO 13857.

Dimensions [mm]

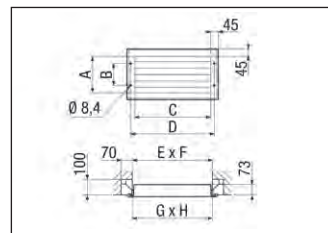

Common features

Material	Sheet steel, galvanised
Installation site	Wall/Channel
Air direction	Ventilation and air extraction

Article	Art. No.	Channel width dimension mm	Channel height dimension mm
LZP 22	0151.0255	500	250
LZP 25	0151.0256	500	300
LZP 28	0151.0257	600	300
LZP 31	0151.0258	600	350
LZP 35	0151.0259	700	400
LZP 50	0151.0314	800	500
LZP 56	0151.0315	1,000	500

Article	A	B	C	D	E	F	G	H
	mm	mm	mm	mm	mm	mm	mm	mm
LZP 22	235	125	485	529	510	260	500	250
LZP 25	285	175	485	529	510	310	500	300
LZP 28	285	175	585	629	610	310	600	300
LZP 31	335	225	585	629	610	360	600	350
LZP 35	385	275	685	729	710	410	700	400
LZP 50	485	375	785	829	810	510	800	500
LZP 56	485	375	985	1,029	1,010	510	1,000	500

Pressure losses

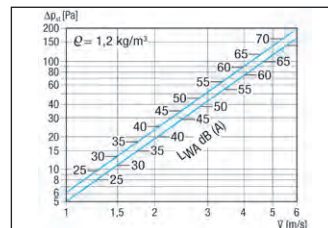

Roof cowls



Roof cowls
DF/DP/BS/RG



- For the routing of supply air or exhaust air from fans or air extraction systems.
- DP ... A: Suitable for flat roofs.
- DP ... TB, DP ... SB, BS ..., RG ..., DF ...: Suitable for 25° to 45° pitched roofs.
- Material: DF ... roof outlet in polypropylene. Roofing tiles for pitched roofs in polyethylene, exception DP 125 TB in lead. Roofing tiles for flat roofs in aluminium.
- No static pressure loss.
- With condensation drainage.
- Reducers must be provided by the customer.
- The DP roofing tile must be used.
- We recommend using BS type mounting clamps for wind pressure resistant roof mounting.
- For flat roof designs:
 - For a warm roof, order 2 roofing tiles DP ... A.
 - For a cold roof, order just 1 roofing tile DP ... A.

Article	Art. No.	Product type	Material
DF 125 T	0092.0373	Roof outlet	Synthetic material
DF 125 S	0092.0374	Roof outlet	Synthetic material
DF 160 S	0092.0375	Roof outlet	Synthetic material
DP 125 TB	0092.0378	Roofing tile	Lead
DP 125 SB	0092.0379	Roofing tile	Bitumen
DP 160 SB	0092.0380	Roofing tile	Bitumen
DP 125 A	0092.0382	Roofing tile	Aluminium
DP 160 A	0092.0383	Roofing tile	Aluminium
BS 125	0092.0359	Mounting clamp	Sheet steel
BS 160	0092.0360	Mounting clamp	Sheet steel
RG 125	0151.0280	Rain protection grille	Aluminium
RG 160	0151.0281	Rain protection grille	Aluminium

Procedure:

Proceed as follows to find the suitable combination of roofing tile, roof outlet and mounting clamp etc. for your application:

- Select the line from the "Requirements" column that best describes your requirements for type of tile and pitch of roof, colour of tile and roof outlet, from the following table.
- The appropriate system composition is shown in the right-hand part of the table.

Dimensions [mm]

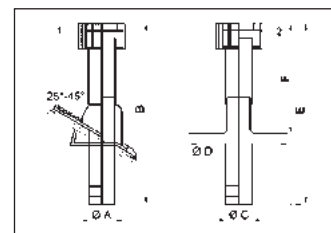

- ① For pitched roofs
- ② For flat roofs

System no.	A mm	B mm	C mm	D mm	E mm	F mm
1 - 2	132	815	-	-	-	-
3 - 4	-	-	132	495	815	465
5	166	1135	-	-	-	-
6	-	-	166	535	1135	620

Requirement				Suitable system composition				
Connection diameter	Type of tile	Colour of tile	Colour roof outlet	Roofing tile	Roof outlet	Mounting clamp	Rain grille	System no.
125	Universal lead tile	Terracotta / lead	Terracotta	DP 125 TB	DF 125 T	BS 125	RG 125	1
125	Universal bitumen tile	Black / bitumen	Black	DP 125 SB	DF 125 S	BS 125	RG 125	2
125	Aluminium flange / flat roof	Aluminium	Black	DP 125 A	DF 125 S	BS 125	RG 125	3
125	Aluminium flange / flat roof	Aluminium	Terracotta	DP 125 A	DF 125 T	BS 125	RG 125	4
160	Universal bitumen tile	Black / bitumen	Black	DP 160 SB	DF 160 S	BS 160	RG 160	5
160	Aluminium flange / flat roof	Aluminium	Black	DP 160 A	DF 160 S	BS 160	RG 160	6

**Outside air wall connection
KW-AL**



- The attractive stainless steel outside air wall supports are fitted on the outside wall of a building and are intended for outside air intake.
- The outside air is drawn in at the bottom.
- An outside air cowl with bird protection grille is included in the scope of delivery.

Dimensions [mm]

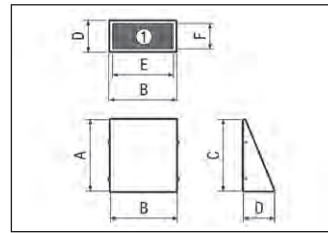

① View from below - outside air intake

Common features

Material	Stainless steel (V2A)
Installation site	Outside wall
Air direction	Ventilation

Article	Art. No.	Colour
KW-AL 12E	0152.0073	Stainless steel, brushed
KW-AL 12W	0152.0074	Pure white, similar to RAL 9010
KW-AL 16E	0152.0077	Stainless steel, brushed
KW-AL 16W	0152.0078	Pure white, similar to RAL 9010
KW-AL 20E	0152.0081	Stainless steel, brushed
KW-AL 20W	0152.0082	Pure white, similar to RAL 9010

Article	A	B	C	D	E	F
	mm	mm	mm	mm	mm	mm
KW-AL 12E	203	172	203	88	148	65
KW-AL 12W	203	172	203	88	148	65
KW-AL 16E	232	228	232	100	203	75
KW-AL 16W	232	228	232	100	203	75
KW-AL 20E	292	280	292	126	226	102
KW-AL 20W	292	280	292	126	226	102

**Outgoing air wall connection
KW-FL**

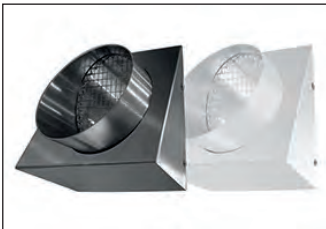

- The attractive stainless steel outgoing air wall supports are fitted on the outside wall of a building and are intended for blowing out outgoing air.
- The outgoing air is blown out to the front.
- An outgoing air cowl with condensate drip edge and bird protection grille is included in the scope of delivery.

Dimensions [mm]

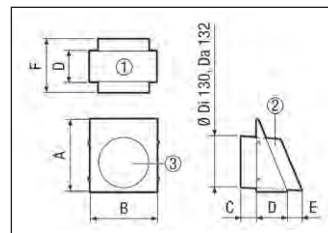

① View from below

② Side view (outgoing air socket)

③ Front view - outgoing air socket

Common features

Material	Stainless steel (V2A)
Installation site	Outside wall
Air direction	Air extraction

Article	Art. No.	Colour
KW-FL 12E	0152.0075	Stainless steel, brushed
KW-FL 12W	0152.0076	Pure white, similar to RAL 9010
KW-FL 16E	0152.0079	Stainless steel, brushed
KW-FL 16W	0152.0080	Pure white, similar to RAL 9010
KW-FL 20E	0152.0083	Stainless steel, brushed
KW-FL 20W	0152.0084	Pure white, similar to RAL 9010

Article	A	B	C	D	E	F
	mm	mm	mm	mm	mm	mm
KW-FL 12E	203	172	50	88	32	170
KW-FL 12W	203	172	50	88	32	170
KW-FL 16E	232	220	45	100	40	185
KW-FL 16W	232	220	45	100	40	185
KW-FL 20E	292	277	40	126	50	215
KW-FL 20W	292	277	40	126	50	215

Wall connections, outside air openings



Combi-wall connections KWH



- The design combi-wall-connection contains outside air and outgoing air sockets in one housing.
- The combi-wall-connection is available as a left-hand or right-hand version.
- This facilitates the laying of ducts in the building between ventilation unit and combi-wall-connection, without crossover.
- Particularly suitable for single family-unit and terraced houses.
- Outside air is sucked in below and the outgoing air is expelled forwards. This minimises the mixing of the two air flows.
- The outgoing air duct connection is inclined a long way to the outside. This disperses the resulting outgoing air condensation.
- Simple installation - consists of two main components:
 - Protective cover
 - Façade part
- The façade fixing points are concealed by the protective cover.
- In locations exposed to the wind or from the second floor upwards, additional measures must be taken to avoid ingress of water through wind pressure or e.g. driving rain at the outgoing air socket.

Article	Art. No.	Model
KWH 12 L	0152.0059	Connections on the left
KWH 12 R	0152.0058	Connections on the right
KWH 16 L	0152.0061	Connections on the left
KWH 16 R	0152.0060	Connections on the right
KWH 20 L	0152.0063	Connections on the left
KWH 20 R	0152.0062	Connections on the right

Dimensions [mm]

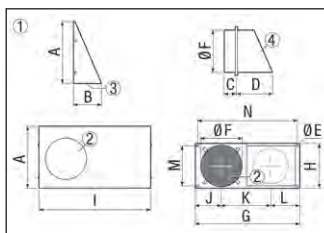

- ① Illustration for right-hand models. The dimensions for the left-hand models are simply mirrored.
- ② Outgoing air
- ③ Outside air
- ④ Inclined connections

Article	A	B	C	D	E	F	G	H	I	J	K	L	M	N
	mm	mm	mm	mm	mm	mm	mm	mm	mm	mm	mm	mm	mm	mm
KWH 12 L	204	88	50	120	6.5	130	352	160	355	78	171	103	141	333
KWH 12 R	204	88	50	120	6.5	130	352	160	355	78	171	103	141	333
KWH 16 L	232	100	50	150	5.5	170	412	185	415	111	190	111	166	393
KWH 16 R	232	100	50	150	5.5	170	412	185	415	111	190	111	166	393
KWH 20 L	282	122	60	160	6.5	215	497	240	500	121	241	135	221	478
KWH 20 R	282	122	60	160	6.5	215	497	240	500	121	241	135	221	478

Common features

Material	Stainless steel (V2A)
Installation site	Outside wall
Air direction	Ventilation and air extraction

Outside air opening ALD 10



- Outside air opening for draught-free, decentralised domestic ventilation.
- Linear control of the air flow.
- No electrical connection required.
- Packing unit: Internal part, dust or insect filter, wall sleeve up to 500 mm, external grille with fly screen.
- Accessories: ALDS 10 storm protection, ALDF 10 replacement filter.

Article	Art. No.
ALD 10	0152.0054

Dimensions [mm]

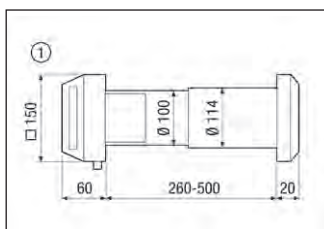

① Inside

Pressure losses

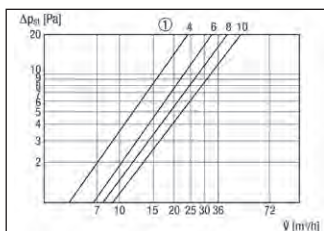

① Valve position in mm

Features

Nominal size	100 mm
Max. volumetric flow	32 m³/h/at 10 Pa
Filter class	G2
Material	Synthetic material
Colour	Pure white, similar to RAL 9010
Installation site	Wall
Rated max. element normal difference in noise level $D_{n,w}$	31 dB
Max. ambient temperature	60 °C
Air direction	Ventilation
Type of shutter	manual

**Storm protection
ALDS 10**

Article	Art. No.
ALDS 10	0152.0056

- Storm protection for air flow regulation with strong or gusty winds.
- Accessories for ALD 10 outside air opening.
- Assembly by sliding into the wall sleeve.

Installation instructions

- In the case of detached buildings it is recommended that installation be made on the weather side and from the 3rd floor upwards.

Features

Nominal size	100 mm
Housing material	Polystyrene
Membrane material	Special silicone

**Outside air openings
ALD 125**

Article	Art. No.	Grille material
ALD 125	0152.0067	Synthetic material
ALD 125 VA	0152.0068	Synthetic (internal grille)/ Stainless steel (external grille)

- Outside air opening for draught-free, decentralised domestic ventilation.
- Type of shutter: Manual (0 % or 100 % position).
- Very good insulation.
- Flat visually appealing design.
- Good air distribution.
- No electrical connection required.
- ALD 125 packing unit: Inner part made of plastic, G2 dust filter, wall sleeve up to 500 mm with storm protection and sound insulation, manual shutter, rectangular plastic external grille including fly screen.
- ALD 125 VA packing unit: Inner part made of plastic, G2 dust filter, wall sleeve up to 500 mm with storm protection and sound insulation, manual shutter, round stainless steel external grille including fly screen.
- Accessories: ALDF 125/160 G2 or ALDF 125/160 G3 replacement filter.

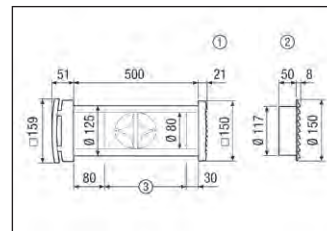
Dimensions [mm]

- ① Rectangular plastic external grille ALD 125
- ② Round stainless steel external grille ALD 125 VA
- ③ Shorten to wall thickness if required

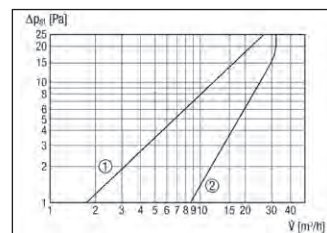
Pressure losses

- ① Dust filter G3
- ② Dust filter G2

Common features

Nominal size	125 mm
Max. volumetric flow	30 m³/h
Filter class	G2
Housing material	Synthetic material
Colour	Pure white, similar to RAL 9010
Installation site	Wall
Rated max. element normal difference in noise level $D_{n,w}$	47 dB
Max. ambient temperature	60 °C
Air direction	Ventilation
Type of shutter	manual, can be locked

**Extension kit
ALDVS 125**

Article	Art. No.
ALDVS 125	0152.0085

- Extension kit for outside air openings ALD 125.
- Scope of delivery:
 - 500 mm long wall sleeve
 - 390 mm long sound-insulated duct

Features

Nominal size	125 mm
Housing material	Synthetic material
Installation site	Outside wall

Outside air openings, airstream limiters



Outside air openings ALD 160



Article	Art. No.	Grille material
ALD 160	0152.0069	Synthetic material
ALD 160 VA	0152.0070	Synthetic (internal grille)/ Stainless steel (external grille)

- Outside air opening for draught-free, decentralised domestic ventilation.
- Type of shutter: Manual (0 % or 100 % position).
- Very good insulation.
- Flat visually appealing design.
- Good air distribution.
- No electrical connection required.
- ALD 160 packing unit: Inner part made of plastic, G2 dust filter, wall sleeve up to 500 mm with storm protection and sound insulation, manual shutter, rectangular plastic external grille including fly screen.
- ALD 160 VA packing unit: Inner part made of plastic, G2 dust filter, wall sleeve up to 500 mm with storm protection and sound insulation, manual shutter, round stainless steel external grille including fly screen.
- Accessories: ALDF 125/160 G2 or ALDF 125/160 G3 replacement filter.

Dimensions [mm]

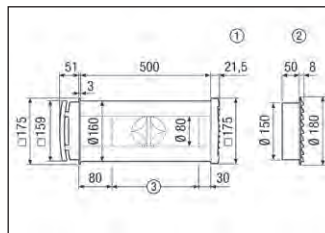

- ① Rectangular plastic external grille ALD 160
- ② Round stainless steel external grille ALD 160 VA
- ③ Shorten to wall thickness if required

Pressure losses

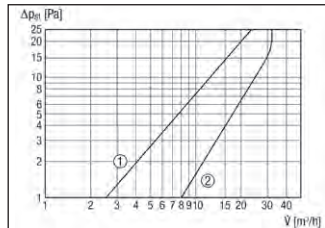

- ① Dust filter G3
- ② Dust filter G2

Common features

Nominal size	160 mm
Max. volumetric flow	30 m³/h
Filter class	G2
Housing material	Synthetic material
Colour	Pure white, similar to RAL 9010
Installation site	Wall
Rated max. element normal difference in noise level $D_{n,w}$	53 dB
Max. ambient temperature	60 °C
Air direction	Ventilation
Type of shutter	manual, can be locked

Extension kit ALDVS 160



Article	Art. No.
ALDVS 160	0152.0086

- Extension kit for outside air openings.
- Scope of delivery:
 - 500 mm long wall sleeve
 - 390 mm long sound-insulated duct

Features

Nominal size	160 mm
Housing material	Synthetic material
Installation site	Outside wall

Airstream limiter VSB



Article	Art. No.	Nominal size mm	Volumetric flow m³/h
VSB 100	0093.0109	100	15 - 110
VSB 125	0093.0110	125	40 - 205

- Volumetric flow limiter for ventilation units and exhaust air systems.
- Simple feeder in DN 100 and/or DN 125 ducts.
- High level of control accuracy.
- Maintenance-free.
- Can be operated in any position.
- Quick and easy to set.

Common features

Housing material	Synthetic material
------------------	--------------------

**Internal shutters, electric
AE**

- Internal shutters for air extraction and ventilation.
- Controls the air flow by adjustable opening and closing angles.
- Thermal energy savings when opened as required.
- Controls using commercial on/off-switches, timers and follow-up relays.
- With operating indicator light.

Article	Art. No.	Nominal size mm
AE 10	0151.0300	100
AE 16	0151.0302	150

Dimensions [mm]

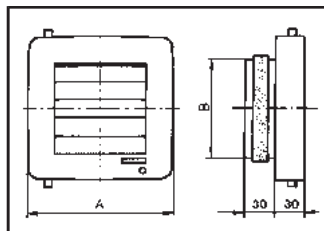

Article	A mm	B mm
AE 10	146	98
AE 16	202	148

Common features

U _{nom}	230 V
f _{nom}	50 Hz
Degree of protection	IP 20
Material	Synthetic material
Colour	Traffic white, similar to RAL 9016
Installation site	Wall/Ceiling
Max. ambient temperature	40 °C
Air direction	Ventilation and air extraction
Type of shutter	electrical

Characteristic curve AE 10

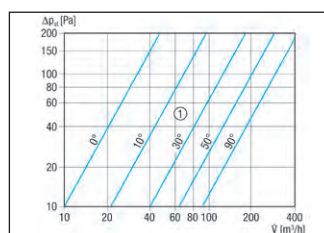

① Opening angle of lamella

Characteristic curve AE 16

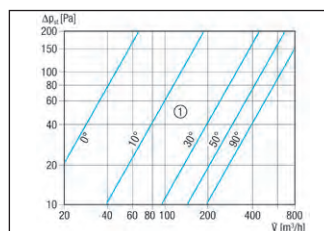

① Opening angle of lamella

**Internal grille
ESG 10/2**



- Internal grille for Ventilation and air extraction.
- With air filter.
- With covered screw holes.
- Cover can be removed without tools for cleaning.
- Sealing tape included in the scope of delivery.
- Accessories: ZRF.. spare air filter.

Article	Art. No.
ESG 10/2	0059.0947

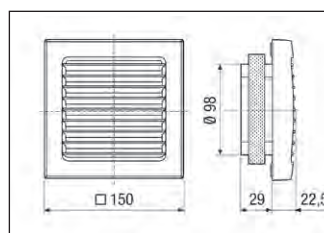
Dimensions [mm]

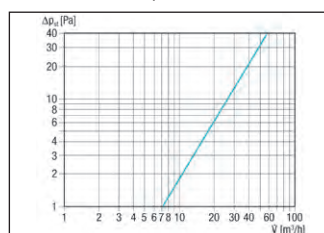

Exhaust air pressure losses

Features

Nominal size	100 mm
Filter class	G2
Material	Synthetic material
Colour	Traffic white, similar to RAL 9016
Installation site	Wall
Max. ambient temperature	60 °C
Air direction	Ventilation and air extraction

**Internal grilles
IG**



- Internal grille for Ventilation and air extraction.

Dimensions [mm]

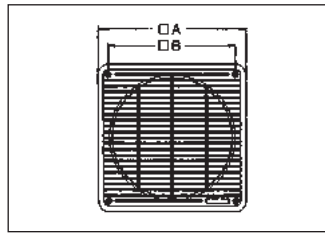

Common features

Loss of pressure	8 Pa
Material	Synthetic material
Colour	Pearl white, similar to RAL 1013
Installation site	Wall
Max. ambient temperature	65 °C
Air direction	Ventilation and air extraction

Article	Art. No.	Nominal size mm
IG 20	0059.0171	200
IG 25	0059.0172	250
IG 30	0059.0173	300
IG 35	0059.0174	350
IG 40	0059.0175	400
IG 45/50	0059.0176	450/500

Article	A mm	B mm
IG 20	258	212
IG 25	320	274
IG 30	365	319
IG 35	428	382
IG 40	470	424
IG 45/50	580	534

**Door ventilation grilles
MLK**



- Door ventilation grille for bathroom, WC or kitchen.
- Free cross section in accordance with FeuVo 80 (German Heating Directives) and TRGI 86 (German Directives for Gas Installation).
- MLK 30: Door cut-out: 275 x 105 mm, external dimension: 295 x 120 mm.
- MLK 45: Door cut-out: 436 x 76 mm, external dimension: 457 x 92 mm.

Common features

Material	Synthetic material
Synthetic material definition	PVC-free polystyrene
Colour	White
Installation site	Door
Open cross section	154 cm ²
Air direction	Ventilation and air extraction
Minimum door leaf thickness	30 mm

Article	Art. No.
MLK 30 white	0151.0123
MLK 45 white	0151.0126

**Protective grilles
SGM/SGM Ex**

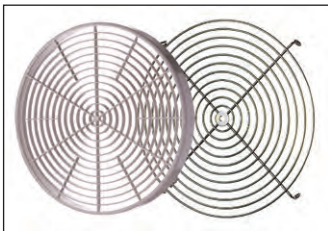

- Protective grille for fans in accordance with DIN EN ISO 13857.
- Can be fitted on the inlet or pressure side.
- SGM: Made of impact-resistant synthetic material, pearl white, similar to RAL 1013, for ERM duct fans.
- SGM ... Ex: Made of metal for ERM-Ex fans, for use in areas subject to explosion hazards.

Dimensions [mm]

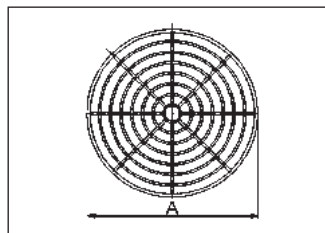

Common features

Air direction	Ventilation and air extraction
---------------	--------------------------------

Article	Art. No.	Nominal size mm	Material
SGM 15	0059.0425	150	Synthetic material
SGM 18	0059.0626	180	Synthetic material
SGM 18 Ex	0150.0131	180	Metal
SGM 22 Ex	0150.0132	225	Metal
SGM 25 Ex	0150.0133	250	Metal

Article	A mm
SGM 15	152
SGM 18	180
SGM 18 Ex	178
SGM 22 Ex	224.5
SGM 25 Ex	249

**Protective grilles, metal
SG**

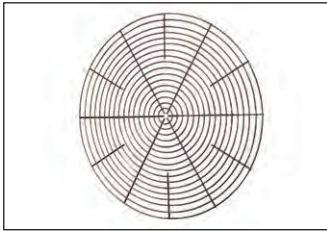

- Protective grille for fans in accordance with DIN EN ISO 13857.
- Suitable for fans with duct connections.
- Can be fitted on the inlet or pressure side.
- Made of antistatic material, for use in areas subject to explosion hazards.

Article	Art. No.	Nominal size mm
SG 20	0150.0114	200
SG 25	0150.0115	250
SG 30	0150.0116	300
SG 35	0150.0117	350
SG 40	0150.0118	400
SG 45	0150.0119	450
SG 50	0150.0120	500
SG 56	0150.0121	560
SG 60	0150.0122	600

Dimensions [mm]

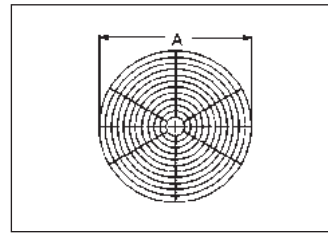

Article	A mm
SG 20	249
SG 25	297
SG 30	369
SG 35	410
SG 40	455
SG 45	500
SG 50	558
SG 56	646
SG 60	698

Common features

Material	Wire, chromated
Air direction	Ventilation and air extraction

Pressure losses

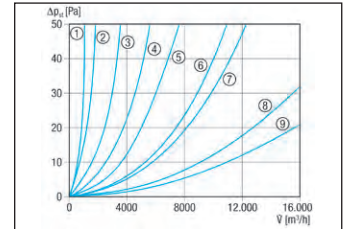

- ① SG 20
- ② SG 25
- ③ SG 30
- ④ SG 35
- ⑤ SG 40
- ⑥ SG 45
- ⑦ SG 50
- ⑧ SG 56
- ⑨ SG 60

**Protective grilles,
synthetic material
SGK**

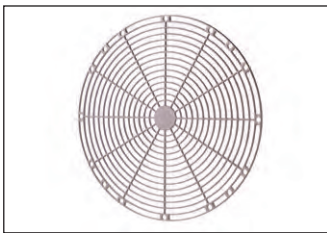

- Protective grille for fans in accordance with DIN EN ISO 13857.
- Suitable for EZQ / DZQ, EZR / DZR and EZD / DZD.
- Can be fitted on the inlet or pressure side.
- Do not use in areas subject to explosions.

Article	Art. No.	Nominal size mm
SGK 20	0059.0161	200
SGK 25	0059.0162	250
SGK 30	0059.0163	300
SGK 35	0059.0164	350
SGK 40	0059.0165	400

Dimensions [mm]

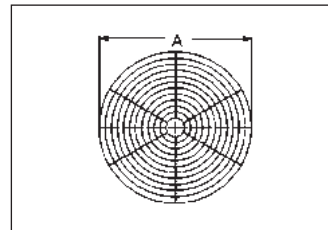

Article	A mm
SGK 20	249
SGK 25	297
SGK 30	369
SGK 35	410
SGK 40	455

Common features

Material	Synthetic material
Max. ambient temperature	65 °C
Air direction	Ventilation and air extraction

Pressure losses

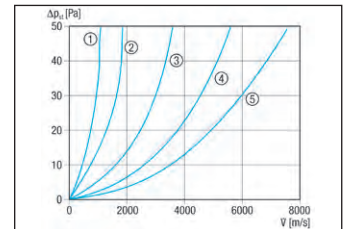

- ① SGK 20
- ② SGK 25
- ③ SGK 30
- ④ SGK 35
- ⑤ SGK 40

Protective grilles, ventilation grilles for installation in ducts and channels



Protective grilles
SGR

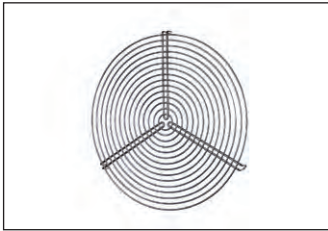

- Protective grille for fans in accordance with DIN EN ISO 13857.
- Suitable for fans with duct connections.
- Can be fitted on the inlet or pressure side.

Dimensions [mm]

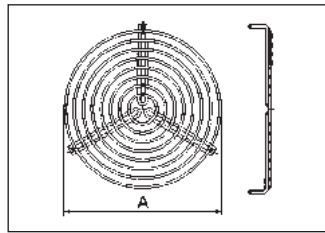

Common features

Material	Wire, chromated
Air direction	Ventilation and air extraction

Article	Art. No.	Nominal size mm
SGR 10	0150.0123	100
SGR 12	0150.0124	125
SGR 16	0150.0125	160
SGR 20	0150.0126	200
SGR 25	0150.0127	250
SGR 31	0150.0128	315

Article	A mm
SGR 10	100
SGR 12	125
SGR 16	160
SGR 20	200
SGR 25	250
SGR 31	315

Internal grilles
LGR

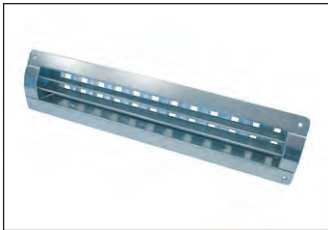

- Internal grille with front frame.
- For installation in folded spiral-seams ducts.
- With horizontal, rotatable air operated lamella with fitted bearings, located on the front side.
- Air flow control by means of adjustable slot slides.
- Ideally (DN 250 for 65 mm mounting height, DN 500 for 115 mm mounting height), the internal grille is fully on the duct.
- With visible screw holes.

Dimensions [mm]

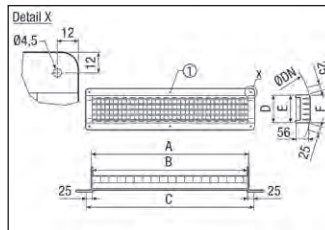

Common features

Material	Sheet steel, galvanised
Installation side	Duct
Air direction	Ventilation and air extraction

Article	Art. No.	Practical air throughput at 75% opening of the slot slide	Suitable for nominal size
LGR 32/6	0151.0354	100 m³/h - 200 m³/h	140 mm - 400 mm (ideal 250 mm)
LGR 42/6	0151.0355	150 m³/h - 250 m³/h	140 mm - 400 mm (ideal 250 mm)
LGR 52/6	0151.0356	200 m³/h - 300 m³/h	140 mm - 400 mm (ideal 250 mm)
LGR 62/6	0151.0357	250 m³/h - 350 m³/h	140 mm - 400 mm (ideal 250 mm)
LGR 82/6	0151.0358	300 m³/h - 500 m³/h	140 mm - 400 mm (ideal 250 mm)
LGR 32/12	0151.0359	200 m³/h - 400 m³/h	300 mm - 800 mm (ideal 500 mm)
LGR 42/12	0151.0360	300 m³/h - 500 m³/h	300 mm - 800 mm (ideal 500 mm)
LGR 52/12	0151.0361	400 m³/h - 600 m³/h	300 mm - 800 mm (ideal 500 mm)
LGR 62/12	0151.0362	500 m³/h - 700 m³/h	300 mm - 800 mm (ideal 500 mm)
LGR 82/12	0151.0363	600 m³/h - 900 m³/h	300 mm - 800 mm (ideal 500 mm)

Ⓞ With LGR 82/6 and LGR 82/12 only

Article	A	B	C	D	E	F
	mm	mm	mm	mm	mm	mm
LGR 32/6	315	312	358	65	60	58
LGR 42/6	415	415	458	65	60	58
LGR 52/6	515	512	558	65	60	58
LGR 62/6	615	612	658	65	60	58
LGR 82/6	815	812	858	65	60	58
LGR 32/12	315	312	358	115	110	108
LGR 42/12	415	415	458	115	110	108
LGR 52/12	515	512	558	115	110	108
LGR 62/12	615	612	658	115	110	108
LGR 82/12	815	812	858	115	110	108

Ventilation grilles for installation in ducts and channels, supply and exhaust air valves

Internal grilles LGA/LGZ



- Internal grille with front frame.
- With vertical, rotatable air operated lamella with fitted bearings, located on the front side.
- Air flow control by means of adjustable slot slides.
- Accessories needed: EK installation box.

Dimensions [mm]

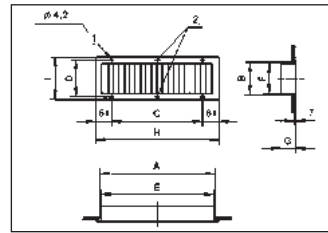

- ① For countersunk head screws
- ② Not available with LGA 42/12 and LGZ 42/12

Common features

Material	Sheet steel, stove-enamelled
Colour	light grey
Installation site	Wall/Channel

Article	Art. No.	Air direction	Practical air throughput at 75% opening of the slot slide
LGA 42/12	0151.0260	Air extraction	100 m ³ /h - 350 m ³ /h
LGA 62/12	0151.0261	Air extraction	200 m ³ /h - 500 m ³ /h
LGA 62/22	0151.0262	Air extraction	300 m ³ /h - 1000 m ³ /h
LGZ 42/12	0151.0263	Ventilation	100 m ³ /h - 350 m ³ /h
LGZ 62/12	0151.0264	Ventilation	200 m ³ /h - 500 m ³ /h
LGZ 62/22	0151.0265	Ventilation	300 m ³ /h - 1000 m ³ /h

Article	A	B	C	D	E	F	G	H	I
	mm	mm	mm	mm	mm	mm	mm	mm	mm
LGA 42/12	425	125	328	140	410	110	61	450	160
LGA 62/12	625	125	528	140	610	110	61	650	160
LGA 62/22	625	225	528	240	610	210	61	650	260
LGZ 42/12	425	125	328	140	410	110	61	450	160
LGZ 62/12	625	125	528	140	610	110	61	650	160
LGZ 62/22	625	225	528	240	610	210	61	650	260

Installation boxes EK



- Installation box for fitting in suspended ceilings.
- For combination with LGA and LGZ internal grilles.

Dimensions [mm]

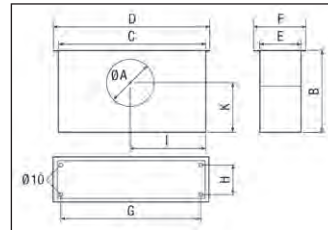

Common features

Material	Sheet steel, galvanised
----------	-------------------------

Article	Art. No.
EK 42/12	0149.0084
EK 62/12	0149.0085
EK 62/22	0149.0086

Article	A	B	C	D	E	F	G	H	I	K
	mm	mm	mm	mm	mm	mm	mm	mm	mm	mm
EK 42/12	157	244	418	448	118	149	400	86	209	91.5
EK 62/12	157	244	619	650	118	149	600	86	309	91.5
EK 62/22	246	333	619	650	218	247	600	184	309	140

Exhaust and supply air valve AZV 100



- Alternative to the disk valve.
- Minimum pressure loss.
- Continuously variable air flow control via setting screw.
- Can be set quickly, easily and precisely.
- The grille setting is retained even once the grille has been removed (for cleaning) and re-inserted.
- High-quality design for the domestic area.
- Covered filter keeps the duct clean.
- G2 filter and sealing strip not included in scope of delivery.
- The filter is washable.
- Alternatively a G3 filter can be used.
- Accessories:
 - ALDF 125/160 G2 replacement air filter
 - ALDF 125/160 G3 replacement air filter

Dimensions [mm]

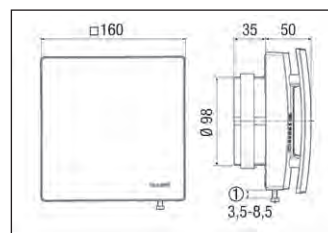

- ① Screw for adjusting the lamella

Pressure losses

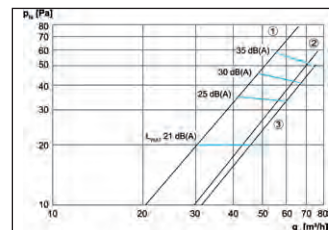

- ① Opening angle 30°
- ② Opening angle 60°
- ③ Max. opening angle 85°

Features

Nominal size	100 mm
Filter class	G2
Material	Synthetic material
Colour	Traffic white, similar to RAL 9016
Type of installation	Surface-mounted
Installation site	Wall
Max. ambient temperature	60 °C
Air direction	Ventilation and air extraction
Width	160 mm
Height	160 mm
Depth	85 mm

Supply and exhaust air valves



Disk valves, synthetic material TK



- Disk valves for Ventilation and air extraction.
- Sealed with a foam ring.
- Linear air flow control via rotatable valve disk.
- Easy installation with mounting ring and clamping springs.
- Recommended accessories: FFE grease filter element for use in rooms where the exhaust air contains grease (e.g. kitchens etc.).

Dimensions [mm]

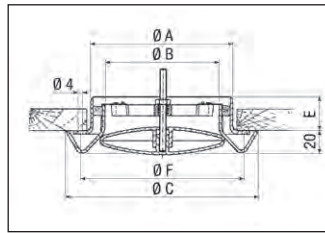

Article	A	B	C	E	F
	mm	mm	mm	mm	mm
TK 10	99	80	150	31	119
TK 12	124	100	170	50	145
TK 15	149	120	190	33	166

Common features

Material	Synthetic material, antistatic
Colour	Pure white, similar to RAL 9010
Air direction	Ventilation and air extraction

Article	Art. No.	Nominal size
		mm
TK 10	0151.0192	100
TK 12	0151.0198	125
TK 15	0151.0193	150

Disk valves, metal TM



- Disk valves for air extraction.
- Linear air flow control via rotatable valve disk.
- Assembly using installation frames.
- Mounting frames and fan housings are linked using a bayonet closure.
- Recommended accessories: FFE grease filter element for use in rooms where the exhaust air contains grease (e.g. kitchens etc.).

Dimensions [mm]

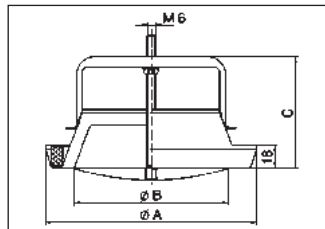

Article	A	B	C
	mm	mm	mm
TM 10	134	87	83
TM 12	162	108	98
TM 15	183	130	97
TM 16	194	135	93

Common features

Material	Sheet steel, stove-enamelled
Colour	Pure white, similar to RAL 9010
Air direction	Air extraction

Article	Art. No.	Nominal size
		mm
TM 10	0151.0194	100
TM 12	0151.0196	125
TM 15	0151.0195	150
TM 16	0151.0197	160

Disk valves, stainless steel TM-V2A



- Stainless steel disk valves for Ventilation and air extraction with connection socket.
- With loose installation ring and spring clamp for simple installation.
- Linear air flow control via rotatable valve disk.
- Recommended accessories: FFE grease filter element for use in rooms where the exhaust air contains grease (e.g. kitchens etc.).

Dimensions [mm]

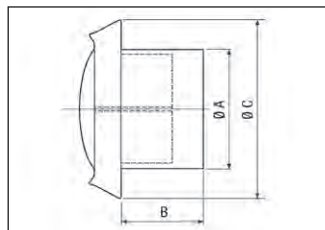

Article	A	B	C
	mm	mm	mm
TM-V2A 10	100	52	140
TM-V2A 12	125	52	170
TM-V2A 16	160	62	225

Common features

Material	Stainless steel
Colour	Stainless steel, brushed
Air direction	Ventilation and air extraction

Article	Art. No.	Nominal size	Open cross section	Sound power level
		mm	cm ²	dB(A)
TM-V2A 10	0151.0374	100	32	35/at max. 80 m ³ /h
TM-V2A 12	0151.0375	125	57	35/at max. 130 m ³ /h
TM-V2A 16	0151.0376	160	90	35/at max. 180 m ³ /h

**Disk valves,
fire protection
TB/WBV**

Article	Art. No.	Nominal size mm	Approval
TB 10	0151.0270	100	Z-41.3-606
TB 12	0151.0271	125	Z-41.3-606
TB 15	0151.0272	150	Z-41.3-606
WBV 10	0151.0275	100	Z-41.3-561
WBV 12	0151.0276	125	Z-41.3-561

- Disk valves for air extraction.
- Mounting frames and fan housings are linked using a bayonet closure.
- Linear air flow control via rotatable valve disk.
- Assembly using installation frames.
- Fire resistance class K 90 - 18017.
- Assembly inside and outside fire-proof shaft walls.
- WBV model series: With maintenance-free fire protection shut-off device and hermetically encapsulated trigger fixture.
- TB model series:
 - Shut-off device locked using cadmium-free melting solder.
 - The melting solder actuates at 72 °C or by hand.
- Recommended accessories: FFE grease filter element for use in rooms where the exhaust air contains grease (e.g. kitchens etc.).

Dimensions [mm]

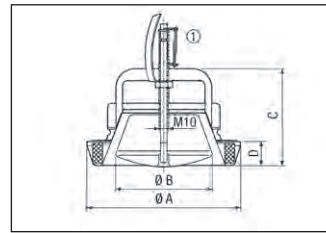

Ⓢ WBV: hermetically encapsulated trigger fixture, TB: melting solder, actuates at 72°C

Article	A mm	B mm	C mm	D mm
TB 10	134	85	83	17
TB 12	162	107	88	17
TB 15	183	130	97	18
WBV 10	134	85	83	17
WBV 12	162	107	88	17

Common features

Material	Sheet steel, powder coated
Colour	Pure white, similar to RAL 9010
Air direction	Air extraction
Fire protection	yes

**Disk valves, metal
TFA**

Article	Art. No.	Nominal size mm
TFA 10	0151.0369	100
TFA 12	0151.0370	125
TFA 15	0151.0371	150
TFA 16	0151.0372	160
TFA 20	0151.0373	200

- Disk valve for air extraction.
- Attractive, flat model.
- Linear air flow control via rotatable valve disk.
- With bayonet closure for mounting frame.
- Accessories needed: Mounting frame with EBR-D / EBR sealing.
- Recommended accessories: FFE grease filter element for use in rooms where the exhaust air contains grease (e.g. kitchens etc.).

Dimensions [mm]

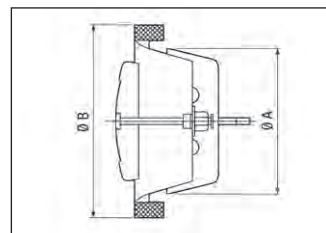

Article	A mm	B mm
TFA 10	100	130
TFA 12	125	160
TFA 15	150	188
TFA 16	160	190
TFA 20	200	245

Common features

Material	Sheet steel, galvanised
Colour	Pure white, similar to RAL 9010, gloss 70
Air direction	Air extraction

**Disk valves, metal
TFZ**

Article	Art. No.	Nominal size mm
TFZ 10	0151.0364	100
TFZ 12	0151.0365	125
TFZ 15	0151.0366	150
TFZ 16	0151.0367	160
TFZ 20	0151.0368	200

- Disk valve for ventilation.
- Attractive, flat model.
- Linear air flow control via rotatable valve disk.
- With bayonet closure for mounting frame.
- Accessories needed: Mounting frame with EBR-D / EBR sealing.

Dimensions [mm]

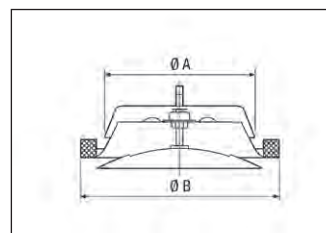

Article	A mm	B mm
TFZ 10	100	130
TFZ 12	125	160
TFZ 15	150	190
TFZ 16	160	190
TFZ 20	200	245

Common features

Material	Sheet steel, galvanised
Colour	Pure white, similar to RAL 9010, gloss 70
Air direction	Ventilation

Supply and exhaust air valves



Mounting frame for TFA/TFZ EBR-D/EBR



- Mounting frame for disk valves with bayonet closure.
- With thread and recessed safe sealing, exception: EBR 15.
- For connecting to the duct.
- Accessories needed for TFA or TFZ metal disk valves.

Dimensions [mm]

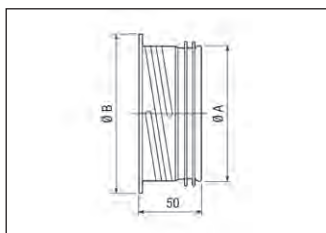

Common features

Material	Sheet steel, galvanised
Colour	galvanised
Air direction	Ventilation and air extraction

Article	Art. No.	Nominal size mm
EBR-D 10	0092.0493	100
EBR-D 12	0092.0494	125
EBR 15	0092.0495	150
EBR-D 16	0092.0496	160
EBR-D 20	0092.0497	200

Article	A mm	B mm
EBR-D 10	100	125
EBR-D 12	125	150
EBR 15	150	175
EBR-D 16	160	185
EBR-D 20	200	225

Grease filter element for exhaust air FFE



- Attractively shaped grease filter element can be used as attachment for exhaust air disk valves with max. depth of 20 mm or as separate component.
- With integrated removable grease filter cassette.
- The cassette can be removed without tools.
- With 4 mounting lugs on the rear.
- Grease filter cassette can be cleaned with hot water, e.g. in sink or dishwasher.
- Simple wall or ceiling installation.
- For use in large and small kitchens.

Characteristic curve

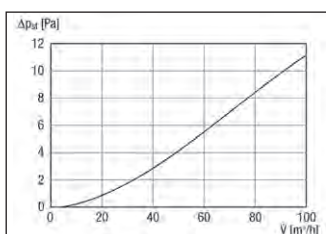

The pressure/air volume characteristic curve shown applies to the clean filter medium. High pressure losses may arise with dirty filters depending on the type and scope of contamination.

Features

Housing material	Sheet steel, powder coated
Grease filter cassette material	Aluminium mesh with expanded metal cover on both sides
Colour	Pure white, similar to RAL 9010
Installation site	Wall/Ceiling
Air direction	Air extraction
Width	190 mm
Height	185 mm
Depth	50 mm

Article	Art. No.
FFE 10	0092.0506

Blower nozzle WD 10 W



- Blower nozzles for ventilation.
- For wall mounting.
- With horizontal air outlet.
- Linear air flow control by means of variable gaps.

Dimensions [mm]

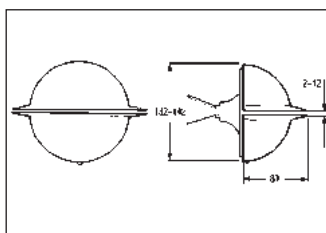

Features

Nominal size	100 mm
Max. volumetric flow	45 m ³ /h
Range of projection	5 m
Material	Sheet steel, powder coated
Colour	Traffic white, similar to RAL 9016
Installation site	Wall
Air direction	Ventilation

Article	Art. No.
WD 10 W	0151.0290

Pressure losses and acoustic data

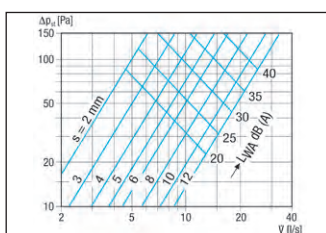

s = gap width

Supply and exhaust air valves, flexible aluminium ducts

**Blower nozzle
WD 10 D**

Article	Art. No.
WD 10 D	0151.0291

- Blower nozzles for ventilation.
- For ceiling installation.
- With horizontal air outlet.
- Linear air flow control by means of variable gaps.

Dimensions [mm]

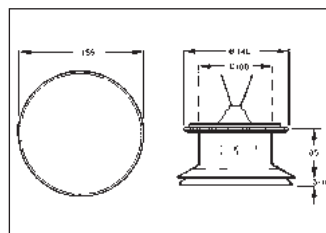
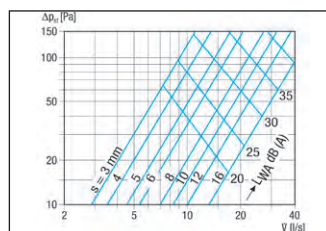
 Pressure losses and
acoustic data

s = gap width

Features

Nominal size	100 mm
Max. volumetric flow	70 m ³ /h
Range of projection	5 m
Material	Sheet steel, powder coated
Colour	Traffic white, similar to RAL 9016
Installation site	Ceiling
Air direction	Ventilation

**Supply air valves
ZWVQ**

Article	Art. No.	Nominal size	Max. volumetric flow
		mm	m ³ /h
ZWVQ 10	0152.0064	100	50
ZWVQ 12	0152.0065	125	90

- In an attractive design for installation on the wall with horizontal air exit. High induction effect with the room air provides good air mixing and draught-free air supply, even at lower temperatures.
- The large range offered by the valve enables a high inflow depth.
- Installation close to the ceiling possible.
- Thanks to its smooth front panel, the supply air valve is very easy to keep clean.
- Removable front panel.
- A simple and accurate volumetric flow setting can be achieved by removing or adding the supplied, invisible stick-on strips over the rows of holes.
- Low background noise.
- The valve with duct connection and rubber seal can be pushed straight into the folded spiral-seams duct.

ZWVQ 10

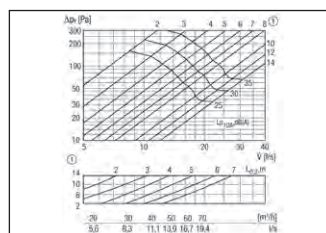

① Open rows of holes

ZWVQ 12

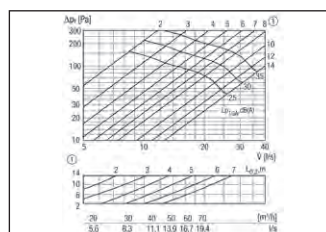

① Open rows of holes

Common features

Material	Sheet steel, galvanised
Colour	White powder-coated, similar to RAL 9010
Installation site	Wall
Air direction	Ventilation
Width	218 mm
Height	156 mm
Depth	60 mm

**Flexible aluminium ducts
AFR**

Article	Art. No.	Nominal size	Length
		mm	m
AFR 75	0055.0088	75	3
AFR 80	0055.0092	80	3
AFR 100	0055.0090	100	10
AFR 125	0055.0091	125	10
AFR 150	0055.0093	150	10

- Flexible five-layered, grooved aluminium duct to be used as connecting duct to the main duct, in accordance with DIN 18017-3.
- Non-combustible in accordance with DIN 4102 class A1 (building material classification).
- Length details: extended length.

Common features

Material	Aluminium
Max. operating pressure	2,500 Pa
Max. ambient temperature	100 °C

Sound absorber box, tubular sound absorbers



Sound absorber box
SB 12/16



Article	Art. No.
SB 12/16	0059.0995

- Sound absorber box for ventilation systems.
- Connection for DN 125 folded spiral-seams duct with SVR 125 plug connector.
- Connection for DN 160 directly on EPP sockets. Seal provided by the customer.
- Insertion loss in the octave band, see www.maico-fans.com.
- Made from sound-absorbing polypropylene (EPP) with hygienic fleece lamination.
- With sound absorbing cover made from melamine resin foam free from mineral fibres.
- Two service openings.
- With pre-drilled holes for installation with threaded rods.

Dimensions [mm]

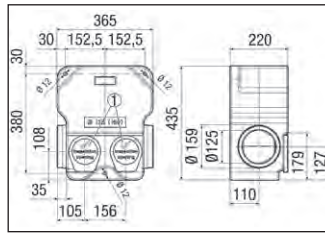

① Service opening

Characteristic curve

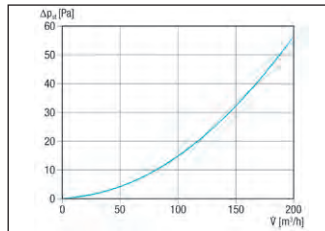

Features

Material	Plastic EPP
Width	435 mm
Height	365 mm
Depth	220 mm

Tubular sound absorbers
RSR



Article	Art. No.	Nominal size mm
RSR 8	0092.0310	80
RSR 10	0092.0311	100
RSR 12	0092.0312	125
RSR 15	0092.0313	150
RSR 16	0092.0314	160
RSR 18	0092.0315	180
RSR 20	0092.0316	200
RSR 25	0092.0317	250
RSR 28	0092.0318	280
RSR 31	0092.0319	315
RSR 10/50	0092.0321	100
RSR 12/50	0092.0322	125
RSR 15/50	0092.0323	150
RSR 16/50	0092.0324	160
RSR 20/50	0092.0326	200
RSR 25/50	0092.0327	250
RSR 31/50	0092.0329	315
RSR 35/50	0092.0335	355
RSR 40/50	0092.0336	400

- Tubular sound absorber for ventilation systems.
- With sound absorbing cover made from fibre glass bound with artificial resin.
- Non-combustible in accordance with DIN 4102 class A1 (building material classification).
- Insertion loss in the octave band, see www.maico-fans.com.
- Insertion loss measured in accordance with DIN 45646.
- RSR...: With 25 mm thick sound absorbing cover.
- RSR.../50: With 50 mm thick sound absorbing cover.

Dimensions [mm]

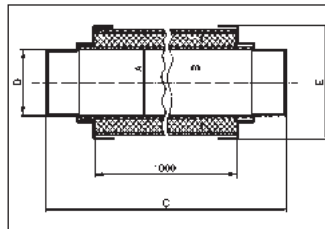

Article	A mm	B mm	C mm	D mm	E mm
RSR 8	80	125	1,120	79.5	129
RSR 10	100	150	1,120	99.5	159.5
RSR 12	125	180	1,120	124.5	189.5
RSR 15	150	200	1,120	149.5	212
RSR 16	160	200	1,120	159.5	212
RSR 18	180	224	1,120	179.5	236
RSR 20	200	250	1,120	199.5	262.5
RSR 25	250	300	1,170	249.4	312.5
RSR 28	280	355	1,170	279.5	362.5
RSR 31	315	355	1,170	314.5	367.5
RSR 10/50	100	200	1,120	99.5	212
RSR 12/50	125	224	1,120	124.5	236
RSR 15/50	150	250	1,120	149.5	262.5
RSR 16/50	160	250	1,120	159.5	262.5
RSR 20/50	200	300	1,120	199.5	312.5
RSR 25/50	250	355	1,170	249.4	362.5
RSR 31/50	315	400	1,170	314.5	413.5
RSR 35/50	355	450	1,220	354.5	463.5
RSR 40/50	400	500	1,170	399.5	513.5

Common features

Material	Aluminium
----------	-----------

Flat oval duct sound absorber, slide-in sound absorber
**Flat oval duct sound absorber
RSOF**

Article	Art. No.	Nominal size mm
RSOF 10/50	0092.0530	100
RSOF 12/50	0092.0531	125
RSOF 16/50	0092.0532	160
RSOF 10/100	0092.0533	100
RSOF 12/100	0092.0534	125
RSOF 16/100	0092.0535	160

- Flat flexible telephony sound absorber in oval version.
- Suitable for reduced installation heights as its flexibility makes it possible to adapt for situations where space is an issue and where the duct feed is difficult.
- The sound absorbers are made of two-layer, flexible aluminium ducts.
- Insertion loss in the octave band, see www.maico-fans.com.
- The inner duct has fine-pored perforations.
- There is an insulation layer made of 50 mm thick synthetic-resin-hardened mineral fibre matting between the inner and outer duct.
- The connection sockets have nipple size and fit in ducts.
- Non-combustible in accordance with EN 13501 A1.

Dimensions [mm]

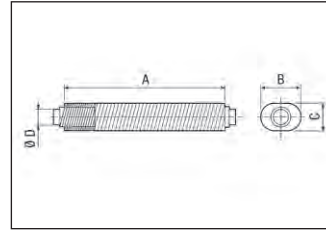

Article	A mm	B mm	C mm	D mm
RSOF 10/50	500	240	150	100
RSOF 12/50	500	265	175	125
RSOF 16/50	500	285	210	160
RSOF 10/100	1,000	240	150	100
RSOF 12/100	1,000	265	175	125
RSOF 16/100	1,000	285	210	160

Common features

Model	50 mm sound absorbing cover
Material	Aluminium
Ambient temperature	200 °C

**Slide-in sound absorber
SDE**

Article	Art. No.	Nominal size mm	External diameter mm
SDE 8	0044.0213	80	82
SDE 10	0044.0214	100	102
SDE 12	0044.0215	125	127
SDE 16	0044.0216	160	162

- Can be used as sound absorber or for pressure control in flexible and folded spiral-seams ducts.
- Suitable for Ventilation and air extraction.
- Can be adjusted to the given circumstances by removing plugs.
- Small hole intended for measuring the air volumes.
- Low space requirement.
- Simple to install.
- Can be retro-fitted.
- Fire- and mould-proof foam, compliant with emission class M1 requirements.
- Easy to clean with a vacuum cleaner.

Installation instructions

- The oval plugs are to be removed prior to installation to meet the corresponding requirements.
- The more plugs are removed the lower the level of sound insulation and pressure loss becomes.
- Insertion loss in the octave band, see www.maico-fans.com.
- Higher sound insulation levels can be achieved by installing several slide-in sound absorbers behind each other. In this case, it is recommended that you remove as many plugs as possible in order to keep the pressure loss at the sound insulation as low as possible.

Common features

Material	PU foam
Installation side	Duct
Depth	50 mm

Required distances

- The distances between the individual sound absorbers indicated below must be adhered to. Otherwise, the values specified in the table no longer apply.

	Distance from the valve	Distance between the sound absorbers
Supply air duct	0 - 50 mm	150 mm
Exhaust air duct	50 - 350 mm	250 mm

Socket sound absorbers, channel sound absorbers



Socket sound absorbers
SD

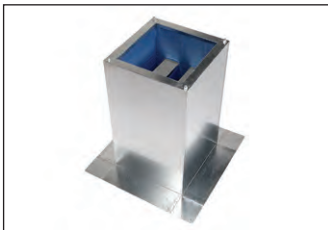

- Silencer for suction side sound insulation of roof fans.
- With silencing elements made of abrasion-resistant and non-flammable mineral fibre plates.
- Recommended accessories: SZ intermediate sockets for connecting ducts.

Dimensions [mm]

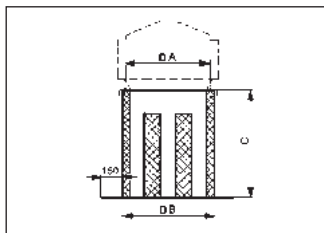

Common features

Housing material	Sheet steel, galvanised
Max. flow velocity	20 m/s

Article	Art. No.	Nominal size mm
SD 18	0092.0337	180
SD 22	0092.0338	225
SD 25	0092.0339	250
SD 31	0092.0340	315
SD 35	0092.0341	355
SD 40	0092.0342	400
SD 45	0092.0343	450
SD 50	0092.0344	500

Article	A mm	B mm	C mm
SD 18	420	465	850
SD 22	460	505	850
SD 25	500	545	850
SD 31	570	615	850
SD 35	610	655	850
SD 40	650	695	850
SD 45	740	785	850
SD 50	800	855	850

Channel sound absorbers
KSP



- Silencer for ventilation systems.
- With silencing elements made from non-abrasive mineral fibre plates, with airtight folded-seam connections covered by galvanised sheet steel.
- Flanges on both sides for installation in square ventilation channels.
- Non-combustible in accordance with DIN 4102.
- KSP ../23 and KSP ../27: With a cover of glass silk fabrics around the silencing elements.
- KSP ../23 and KSP ../27: Adaptors are required and have to be supplied by the customer (see channel dimension A x B).
- Insertion loss in the octave band, see www.maico-fans.com.

Dimensions [mm]

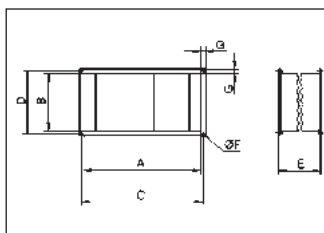

Common features

Housing material	Sheet steel, galvanised
Max. flow velocity	20 m/s
Installation site	Channel

Article	Art. No.	Channel width dimension mm	Channel height dimension mm
KSP 22/15	0092.0301	500	250
KSP 25/15	0092.0302	500	300
KSP 28/14	0092.0303	600	300
KSP 31/14	0092.0304	600	350
KSP 35/14	0092.0305	700	400
KSP 22/27	0092.0330	600	250
KSP 25/27	0092.0331	600	300
KSP 28/23	0092.0332	700	300
KSP 31/27	0092.0333	1,000	350
KSP 35/23	0092.0334	1,000	400
KSP 50/23	0092.0306	1,000	500
KSP 56/25	0092.0307	1,350	500
KSP 93/28	0092.0504	900	300
KSP 94/28	0092.0505	900	400

Article	A mm	B mm	C mm	D mm	E mm	F mm	G mm
KSP 22/15	500	250	520	270	900	9	20
KSP 25/15	500	300	520	320	900	9	20
KSP 28/14	600	300	620	320	600	9	20
KSP 31/14	600	350	620	370	600	9	20
KSP 35/14	700	400	720	420	600	9	20
KSP 22/27	600	250	620	270	1,250	12	20
KSP 25/27	600	300	620	320	1,250	12	20
KSP 28/23	700	300	720	320	1,500	12	20
KSP 31/27	1,000	350	1,020	370	1,250	12	20
KSP 35/23	1,000	400	1,020	420	1,500	12	20
KSP 50/23	1,000	500	1,020	520	1,500	12	20
KSP 56/25	1,350	500	1,370	520	1,500	12	20
KSP 93/28	900	300	920	320	1,250	9	20
KSP 94/28	900	400	920	420	1,250	9	20

**Electrical air heaters
ERH/DRH**

Article	Art. No.	U _{nom} V	Nom-Heater inal power size rating	W
ERH 10-04	0082.0100	230	100	400
ERH 12-1	0082.0101	230	125	1,200
ERH 16-2	0082.0102	230	160	2,100
ERH 20-2	0082.0103	230	200	2,100
ERH 25-2	0082.0104	230	250	2,100
DRH 16-5	0082.0105	400	160	5,000
DRH 20-5	0082.0106	400	200	5,000
DRH 25-6	0082.0107	400	250	6,000
DRH 31-6	0082.0108	400	315	6,000

- Electrical air heater for ventilation systems.
- With non-glowing stainless steel tubular radiators.
- Operate with ETL/DTL temperature controller (see accessories).
- Increased danger of fire if tubular radiators are dirty. Install TFE air filter as a prevention.
- Recommended accessories: FL channel sensor or FR room sensor, LW 9 air flow monitor, US 16 T contactor and TFE... air filter .

Dimensions [mm]

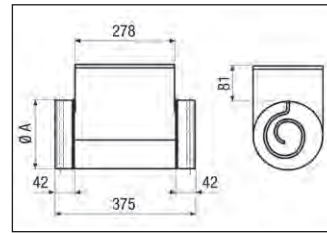

Article	A mm
ERH 10-04	100
ERH 12-1	125
ERH 16-2	160
ERH 20-2	200
ERH 25-2	250
DRH 16-5	160
DRH 20-5	200
DRH 25-6	250
DRH 31-6	315

Common features

f _{nom}	50 Hz
Degree of protection	IP 43
Housing material	Sheet steel, galvanised

Pressure losses

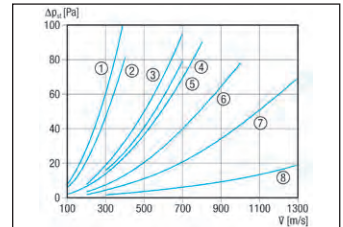

- DRH 16-5
- ERH 12-1
- ERH 16-2
- ERH 10-04
- DRH 20-5
- DRH 25-6
- ERH 20-2
- ERH 25-2
- DRH 31-6

Temperature rise

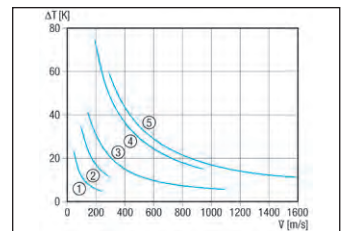

- ERH 10-4
- ERH 12-1
- ERH 16-2, ERH 20-2, ERH 25-2
- DRH 16-5, DRH 20-5
- DRH 25-6, DRH 31-6

**Electrical air heaters
with controller
ERH R/DRH R**

Article	Art. No.	U _{nom} V	Nominal size mm	Heater power rating W
ERH 16-2 R	0082.0142	230	160	2,100
DRH 16-5 R	0082.0143	400	160	5,000
DRH 20-6 R	0082.0144	400	200	6,000
DRH 25-9 R	0082.0145	400	250	9,000
DRH 31-12 R	0082.0146	400	315	12,000
DRH 35-12 R	0082.0147	400	350	12,000
DRH 40-12 R	0082.0148	400	400	12,000

- Electrical air heater for ventilation systems.
- With integrated temperature controller.
- With non-glowing stainless steel tubular radiators.
- FR 30 P room sensor and FL 30 P channel sensor included in the scope of delivery.
- Increased danger of fire if tubular radiators are dirty. Install TFE air filter as a prevention.
- Recommended accessories: LW 9 air flow monitor and TFE... air filter.

Dimensions [mm]

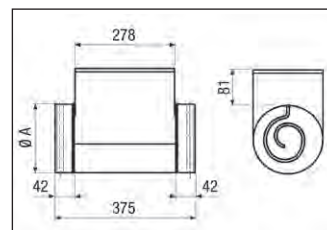

DRH 35-12 R: No rubber seal on the connection couplings

Article	A mm
ERH 16-2 R	160
DRH 16-5 R	160
DRH 20-6 R	200
DRH 25-9 R	250
DRH 31-12 R	315
DRH 35-12 R	350
DRH 40-12 R	400

Common features

f _{nom}	50 Hz
Degree of protection	IP 43
Housing material	Sheet steel, galvanised

Pressure losses

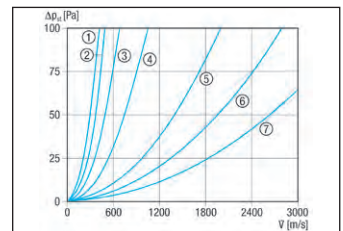

- ERH 16-2 R
- DRH 16-5 R
- DRH 20-6 R
- DRH 25-9 R
- DRH 31-12 R
- DRH 35-12 R
- DRH 40-12 R

Electrical air heaters



Electrical air heaters
DHP



- Electrical air heater for ventilation systems.
- Flanges on both sides for installation in square ventilation channels.
- With non-glowing stainless steel tubular radiators.
- Heater power rating linearly adjustable.
- Operate with DTL 24 P temperature control system (see accessories).
- Recommended accessories: FL channel sensor or FR room sensor, LW 9 air flow monitor, TFP ... air filter, US 16 T contactor, DTL 2 P-L (at 16.5 kW to 30 kW).

Safety instructions

- Increased danger of fire if tubular radiators are dirty. Install TFP air filter.
- With 2 temperature limiters switching independently of each other.
- Minimum distance to inflammable material: 300 mm (if distance is less, install appropriate insulation).

Dimensions [mm]

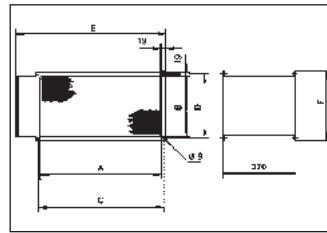

Article	A	B	C	D	E	F
	mm	mm	mm	mm	mm	mm
DHP 22-9	500	250	520	270	639	288
DHP 22-16	500	250	520	270	639	288
DHP 25-16	500	300	520	320	639	338
DHP 28-16	600	300	620	320	739	338
DHP 28-28	600	300	620	320	739	338
DHP 31-16	600	350	620	370	739	388
DHP 31-28	600	350	620	370	739	388

Common features

U _{nom}	400 V
f _{nom}	50 Hz
Degree of protection	IP 43
Housing material	Sheet steel, galvanised
Installation site	Channel

Pressure losses

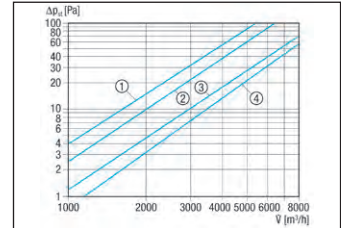

- ① DHP 25-16
- ② DHP 22-9, DHP 28-16, DHP 28-28
- ③ DHP 31-28
- ④ DHP 31-16

Temperature rise

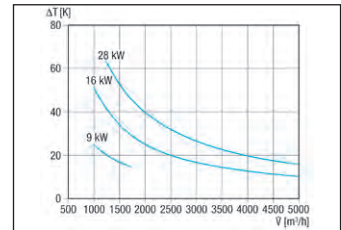

Article	Art. No.	I _{max}	Channel width dimension	Channel height dimension	Heater power rating
		A	mm	mm	W
DHP 22-9	0082.0090	13	500	250	9,000
DHP 22-16	0082.0091	23.1	500	250	16,000
DHP 25-16	0082.0093	23.1	500	300	16,000
DHP 28-16	0082.0098	23.1	600	300	16,000
DHP 28-28	0082.0095	40.5	600	300	28,000
DHP 31-16	0082.0099	23.1	600	350	16,000
DHP 31-28	0082.0097	40.5	600	350	28,000

**Water air heaters
WRH**

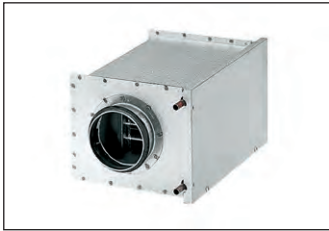

- Water air heater for ventilation systems.
- Connections made of copper.
- Housing cover can be removed for service work.
- With rubber seal on the air connection couplings.

Dimensions [mm]

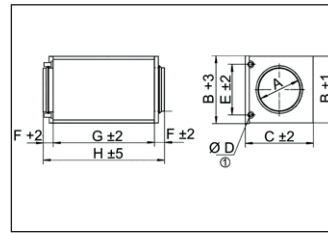

ⓐ External connection diameter

Article	Art. No.	Nominal size mm	Heater power rating W	Open cross section cm ²
WRH 10-1	0082.0116	100	1,300	1,012
WRH 12-1	0082.0117	125	1,700	1,215
WRH 16-2	0082.0118	160	3,800	1,458
WRH 20-2	0082.0119	200	5,000	1,701
WRH 25-4	0082.0120	250	8,300	2,268
WRH 31-6	0082.0121	315	13,100	3,240
WRH 40-9	0082.0122	400	20,600	4,050

Article	A	B	C	D	E	F	G	H
	mm	mm	mm	mm	mm	mm	mm	mm
WRH 10-1	100	183	225	10	137	40	300	380
WRH 12-1	125	183	225	10	137	40	300	380
WRH 16-2	160	258	305	10	212	40	300	380
WRH 20-2	200	258	305	10	212	40	300	380
WRH 25-4	250	333	385	22	250	40	300	380
WRH 31-6	315	408	460	22	325	40	300	380
WRH 40-9	400	483	540	22	400	70	300	440

Common features

Housing material	Sheet steel, galvanised
Inlet temperature	70 °C
Return flow temperature	50 °C
Max. water temperature	100 °C
Max. water pressure	6 bar

Pressure losses

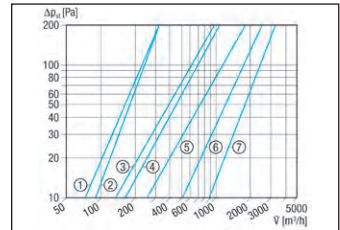

- ① WRH 10-1
- ② WRH 12-1
- ③ WRH 16-2
- ④ WRH 20-2
- ⑤ WRH 25-4
- ⑥ WRH 31-6
- ⑦ WRH 40-9

Temperature rise

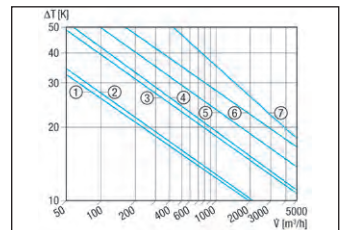

- ① WRH 10-1
- ② WRH 12-1
- ③ WRH 16-2
- ④ WRH 20-2
- ⑤ WRH 25-4
- ⑥ WRH 31-6
- ⑦ WRH 40-9

Water air heaters



Water air heaters
WHP

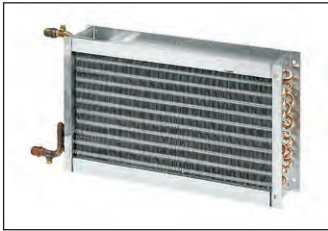

- Water air heater for ventilation systems.
- Water connection made of copper tubes with external threads.
- Mounting instructions: Install behind the fan at distances of at least 1 metre, to achieve equal flows.
- With air extraction and emptying. Take accessibility into account when installing.
- Frost protection must be supplied by the customer.
- With floating offset collecting pipes, to compensate for heat expansion.

Dimensions [mm]

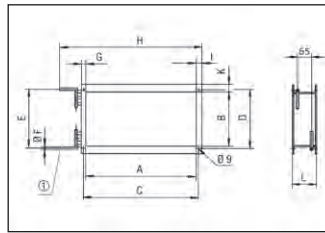

① Whitworth thread: 1/2" for WHP 22-18 and WHP 25-22; 3/4" for WHP 28-29, WHP 31-34 and WHP 35-43; 1" for WHP 50-55 and WHP 56-69

Common features

Housing material	Sheet steel, galvanised
Installation site	Channel
Inlet temperature	70 °C
Return flow temperature	50 °C
Max. water temperature	100 °C
Max. water pressure	8 bar

Article	Art. No.	Channel width dimension mm	Channel height dimension mm	Heater power rating W	A	B	C	D	E	F	G	H	I	K	L
WHP 22-18	0082.0111	500	250	17,700	500	250	520	270	272	16	20	645	25	35	110
WHP 25-22	0082.0112	500	300	21,700	500	300	520	320	322	16	20	645	25	35	110
WHP 28-29	0082.0113	600	300	29,400	600	300	620	320	318	22	20	745	25	35	110
WHP 31-34	0082.0114	600	350	33,600	600	350	620	370	368	22	20	745	25	35	110
WHP 35-43	0082.0115	700	400	43,000	700	400	720	420	418	22	20	845	25	35	110
WHP 50-55	0082.0123	800	500	55,000	740	500	820	520	475	28	40	1,006	55	35	120
WHP 56-69	0082.0124	1,000	500	69,000	940	500	1,020	520	475	28	40	1,206	55	35	120

Pressure losses

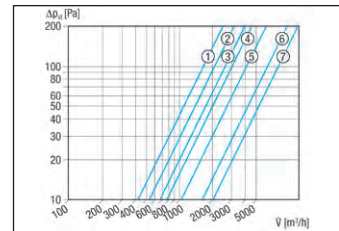

- ① WHP 22-18
- ② WHP 25-22
- ③ WHP 28-29
- ④ WHP 31-34
- ⑤ WHP 35-43
- ⑥ WHP 50-55
- ⑦ WHP 56-69

Temperature rise

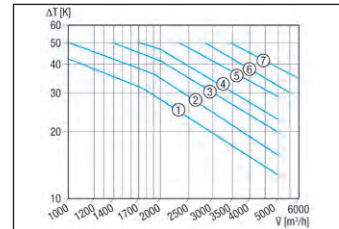

- ① WHP 22-18
- ② WHP 25-22
- ③ WHP 28-29
- ④ WHP 31-34
- ⑤ WHP 35-43
- ⑥ WHP 50-55
- ⑦ WHP 56-69

Air filters
TFE -4

Article	Art. No.	Nominal size mm
TFE 10-4	0149.0074	100
TFE 12-4	0149.0075	125
TFE 15-4	0149.0076	150
TFE 16-4	0149.0077	160
TFE 20-4	0149.0078	200
TFE 25-4	0149.0079	250
TFE 31-4	0149.0080	315
TFE 35-4	0149.0081	355
TFE 40-4	0149.0082	400

- Air filter for ventilation systems.
- Inspection lid can be removed for easy filter exchange.
- With filter insert made of synthetic fibre.
- Filter insert cannot be regenerated.
- With rubber seal on the air connection couplings.
- Accessories: Replacement air filter FE..
- Recommended accessories: DW 1000 differential pressure controller.

Dimensions [mm]

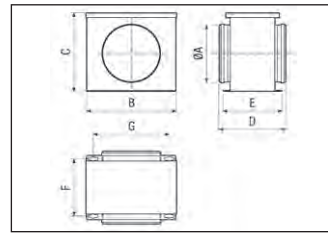

Article	A	B	C	D	E	F	G
	mm	mm	mm	mm	mm	mm	mm
TFE 10-4	100	205	165	170	142	117	150
TFE 12-4	125	210	200	190	165	138	160
TFE 15-4	150	260	230	205	178	152	210
TFE 16-4	160	260	230	205	178	152	210
TFE 20-4	200	310	275	230	222	182	260
TFE 25-4	250	365	325	325	252	227	310
TFE 31-4	315	425	390	420	352	327	370
TFE 35-4	355	505	495	550	478	457	445
TFE 40-4	400	505	495	570	478	457	445

Common features

Filter class	G4
Housing material	Sheet steel, galvanised
Max. ambient temperature	100 °C

Pressure losses

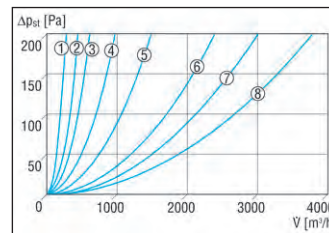

- ① TFE 10-4
- ② TFE 12-4
- ③ TFE 15-4, TFE 16-4
- ④ TFE 20-4
- ⑤ TFE 25-4
- ⑥ TFE 31-4
- ⑦ TFE 35-4
- ⑧ TFE 40-4

**Air filters, replacement
FE**

Article	Art. No.	Nominal size mm
FE 10-1	0093.1221	100
FE 12-1	0093.1222	125
FE 15-1	0093.1223	150
FE 16-1	0093.1224	160
FE 20-1	0093.1225	200
FE 25-1	0093.1226	250
FE 31-2	0093.1227	315
FE 35-2	0093.1228	350
FE 40-2	0093.1229	400

- Replacement filter for TFE...-4 air filter.

Article	Width mm	Height mm	Depth mm
FE 10-1	220	170	10
FE 12-1	230	200	10
FE 15-1	285	230	8
FE 16-1	285	230	8
FE 20-1	340	270	8
FE 25-1	408	318	8
FE 31-2	520	390	6
FE 35-2	655	490	6
FE 40-2	670	490	10

Common features

Filter class	G4
Material	Synthetic
Max. ambient temperature	100 °C
Packing unit	2 pieces

Air filters



**Air filters
TFE -5/TFE -7**



- Air filter for ventilation systems.
- Inspection lid can be removed for easy filter exchange.
- With filter insert made of synthetic fibre.
- Panel filter.
- Filter insert cannot be regenerated.
- With rubber seal on the air connection couplings.
- TFE ...-5: Filter class F5, accessories for replacement filter RF...-5
- TFE ...-7: Filter class F7, accessories for replacement filter RF...-7
- Recommended accessories: DW 1000 differential pressure controller.

Article	Art. No.	Nominal size mm	Filter class
TFE 10-5	0149.0058	100	F5
TFE 12-5	0149.0059	125	F5
TFE 15-5	0149.0060	150	F5
TFE 16-5	0149.0061	160	F5
TFE 20-5	0149.0062	200	F5
TFE 25-5	0149.0063	250	F5
TFE 31-5	0149.0064	315	F5
TFE 35-5	0149.0065	355	F5
TFE 40-5	0149.0066	400	F5
TFE 10-7	0149.0049	100	F7
TFE 12-7	0149.0050	125	F7
TFE 15-7	0149.0051	150	F7
TFE 16-7	0149.0052	160	F7
TFE 20-7	0149.0053	200	F7
TFE 25-7	0149.0054	250	F7
TFE 31-7	0149.0055	315	F7
TFE 35-7	0149.0056	355	F7
TFE 40-7	0149.0057	400	F7

Dimensions [mm]

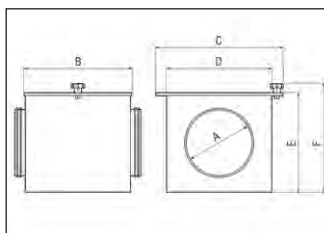

Article	A mm	B mm	C mm	D mm	E mm	F mm
TFE 10-5	100	300	360	300	300	330
TFE 12-5	125	300	360	300	300	330
TFE 15-5	150	300	360	300	300	330
TFE 16-5	160	300	360	300	300	330
TFE 20-5	200	300	360	300	300	330
TFE 25-5	250	300	360	300	300	330
TFE 31-5	315	300	460	400	500	530
TFE 35-5	355	300	460	400	500	530
TFE 40-5	400	300	560	500	500	530
TFE 10-7	100	300	360	300	300	330
TFE 12-7	125	300	360	300	300	330
TFE 15-7	150	300	360	300	300	330
TFE 16-7	160	300	360	300	300	330
TFE 20-7	200	300	360	300	300	330
TFE 25-7	250	300	360	300	300	330
TFE 31-7	315	300	460	400	500	530
TFE 35-7	355	300	460	400	500	530
TFE 40-7	400	300	560	500	500	530

Common features

Housing material	Sheet steel, galvanised
Max. ambient temperature	80 °C

TFE -5 pressure losses

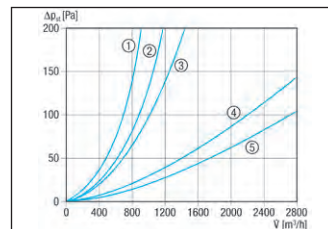

- ① TFE 10-5 to TFE 16-5
- ② TFE 20-5
- ③ TFE 25-5
- ④ TFE 31-5 and TFE 35-5
- ⑤ TFE 40-5

TFE -7 pressure losses

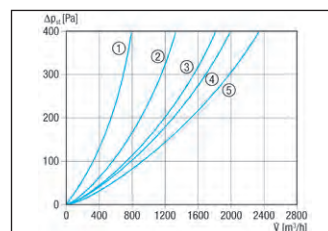

- ① TFE 10-7 to TFE 16-7
- ② TFE 20-7
- ③ TFE 25-7
- ④ TFE 31-7 and TFE 35-7
- ⑤ TFE 40-7

**Air filters, replacement
RF -5/RF -7**

Article	Art. No.	Nominal size in mm	Filter class
RF 10/16-5	0093.0875	100-160	F5
RF 20-5	0093.0876	200	F5
RF 25-5	0093.0877	250	F5
RF 31/35-5	0093.0878	315-355	F5
RF 40-5	0093.0879	400	F5
RF 10/16-7	0093.0880	100-160	F7
RF 20-7	0093.0881	200	F7
RF 25-7	0093.0882	250	F7
RF 31/35-7	0093.0883	315-355	F7
RF 40-7	0093.0884	400	F7

- Replacement filter for TFE air filter.
- RF ...-5: Replacement filter for TFE...-5.
- RF ...-7: Replacement filter for TFE...-7.

Article	Width mm	Height mm	Depth mm
RF 10/16-5	288	288	28
RF 20-5	288	288	50
RF 25-5	285	285	98
RF 31/35-5	495	395	50
RF 40-5	495	495	48
RF 10/16-7	290	290	28
RF 20-7	290	290	50
RF 25-7	290	290	97
RF 31/35-7	490	390	50
RF 40-7	495	495	48

Common features

Max. ambient temperature	80 °C
Packing unit	2 pieces

**Air filters, replacement
RF**

Article	Art. No.	Nominal size mm
RF 10-16	0093.0690	100
RF 20	0093.0693	200
RF 25	0093.0694	250
RF 31	0093.0695	315
RF 35	0093.0691	355
RF 40	0093.0692	400

- Replacement filter for TFE... air filter.

Article	Width mm	Height mm	Depth mm
RF 10-16	230	200	8
RF 20	265	240	6
RF 25	294	215	6
RF 31	360	340	8
RF 35	458	445	6
RF 40	458	455	6

Common features

Filter class	G4
Max. ambient temperature	100 °C
Packing unit	2 pieces

**Air filter, replacement
PF 10/16**

Article	Art. No.
PF 10/16	0093.0698

- Replacement air filter for TFE 10, TFE 12, TFE 15 and TFE 16 air filters.

Features

Filter class	F7
Width	200 mm
Height	200 mm
Depth	25 mm

**Air filters
TFP**

- Air filter for ventilation systems.
- Flanges on both sides for installation in square ventilation channels.
- Inspection lid can be removed for easy filter exchange.
- Accessories: KF.. replacement air filter and DW 1000 differential pressure controller.

Dimensions [mm]

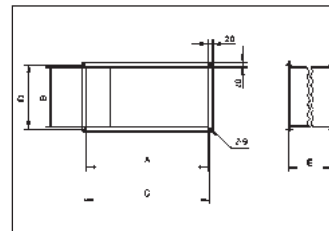

Article	Art. No.	Chan- nel width dimen- sion mm	Chan- nel height dimen- sion mm	Filter class
TFP 22	0149.0031	500	250	G4
TFP 25	0149.0032	500	300	G4
TFP 28	0149.0033	600	300	G4
TFP 31	0149.0034	600	350	G4
TFP 35	0149.0035	700	400	G4
TFP 50	0149.0036	800	500	G4
TFP 56	0149.0037	1,000	500	G4
TFP 22-7	0149.0067	500	250	F7
TFP 25-7	0149.0068	500	300	F7
TFP 28-7	0149.0069	600	300	F7
TFP 31-7	0149.0070	600	350	F7
TFP 35-7	0149.0071	700	400	F7
TFP 50-7	0149.0072	800	500	F7
TFP 56-7	0149.0073	1,000	500	F7

Article	A	B	C	D	E
	mm	mm	mm	mm	mm
TFP 22	500	250	520	270	500
TFP 25	500	300	520	320	500
TFP 28	600	300	620	320	550
TFP 31	600	350	620	370	600
TFP 35	700	400	720	420	600
TFP 50	800	500	820	520	700
TFP 56	1,000	500	1,020	520	700
TFP 22-7	500	250	520	270	500
TFP 25-7	500	300	520	320	500
TFP 28-7	600	300	620	320	550
TFP 31-7	600	350	620	370	600
TFP 35-7	700	400	720	420	600
TFP 50-7	800	500	820	520	700
TFP 56-7	1,000	500	1,020	520	700

Common features

Housing material	Sheet steel, galvanised
Installation site	Channel

TFP pressure losses

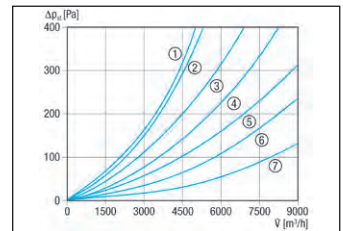

- ① TFP 22
- ② TFP 25
- ③ TFP 28
- ④ TFP 31
- ⑤ TFP 35
- ⑥ TFP 50
- ⑦ TFP 56

TFP-7 pressure losses

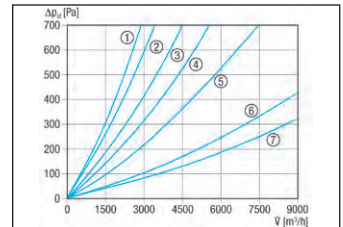

- ① TFP 22-7
- ② TFP 25-7
- ③ TFP 28-7
- ④ TFP 31-7
- ⑤ TFP 35-7
- ⑥ TFP 50-7
- ⑦ TFP 56-7

Air filters



**Air filters, replacement
KF**

- Replacement filter for TFP and TFP -7.
- Pocket filter.

Article	Art. No.	Channel dimension width mm	Channel dimension height mm	Filter class
KF 22	0093.0681	500	250	G4
KF 25	0093.0682	500	300	G4
KF 28	0093.0683	600	300	G4
KF 31	0093.0684	600	350	G4
KF 35	0093.0685	700	400	G4
KF 50	0093.0686	800	500	G4
KF 56	0093.0687	1,000	500	G4
KF 22-7	0093.0863	500	250	F7
KF 25-7	0093.0864	500	300	F7
KF 28-7	0093.0865	600	300	F7
KF 31-7	0093.0866	600	350	F7
KF 35-7	0093.0867	700	400	F7
KF 50-7	0093.0868	800	500	F7
KF 56-7	0093.0869	1,000	500	F7

Common features

Max. ambient temperature	70 °C
Packing unit	2 pieces

**Air filters
ZFF**



- Air filter for cleaning the fresh air supply.
- With finger guard.
- Easy filter change.
- Accessories: FF.. replacement air filter.

Dimensions [mm]

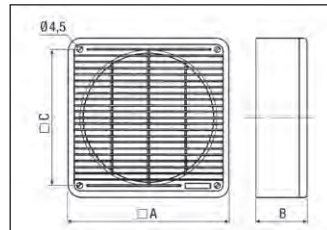

Common features

Filter class	G2
Material	Synthetic material
Colour	Pearl white, similar to RAL 1013

Article	Art. No.	Nominal size mm
ZFF 20	0149.0001	200
ZFF 30	0149.0003	250/300
ZFF 40	0149.0005	350/400

Article	A mm	B mm	C mm
ZFF 20	258	82	212
ZFF 30	365	92	319
ZFF 40	470	112	423

**Air filters, replacement
FF**

- Replacement filter for ZFF air filter.

Article	Art. No.	Nominal size mm
FF 20	0093.0230	200
FF 30	0093.0232	250/300
FF 40	0093.0234	350/400

Article	Width mm	Height mm	Depth mm
FF 20	298	255	6
FF 30	405	355	6
FF 40	510	465	6

Common features

Filter class	G2
Packing unit	3 pieces

**Air filters, replacement
ZF/FF/SF**

Article	Art. No.	Packing unit	Filter class
ZF 60/100	0093.0680	5 pieces	G2
ZF 60/100 bulk container	0093.0885	100 pieces	G2
ZF 17	0093.0644	5 pieces	G2
ZF 17 S	0093.0675	5 pieces	G2
ZF 17-1	0093.0676	5 pieces	EU4
FF 10	0093.0377	5 pieces	G2
FF 17	0093.0343	5 pieces	EU2
FF 133	0093.0019	5 pieces	G4
SF 17/100	0093.0671	5 pieces	G2

- ZF 60/100: Replacement air filter for ER and ER-AP/ER-APB fan inserts and Centro exhaust air elements.
- ZF 17: Replacement air filter for ERA 17 surface-mounted fan.
- ZF 17 S: Replacement air filter for ER 17/60-2... and ER 17/100... fan insert.
- ZF 17-1: Replacement air filter for ER 17/60-1... fan insert.
- FF 10: Replacement air filter for ERA 11 surface-mounted fan.
- FF 17: Replacement air filter for EMA 17 wall-mounted fan.
- FF 133: Replacement air filter for UPR 133 exhaust fan.
- SF 17/100: Replacement filter mats for second room connection set S 17/100.

Article	Width mm	Height mm	Depth mm
ZF 60/100	135	135	8
ZF 60/100 bulk container	135	135	8
ZF 17	144	144	0
ZF 17 S	220	34	0
ZF 17-1	144	144	0
FF 10	260	163	10
FF 17	290	170	0
FF 133	125	125	16
SF 17/100	110	110	10

**Air filter, replacement
ZRF**

Article	Art. No.
ZRF	0093.0923

- Replacement filter for ER-ZR second room connection kit and for AZE 100 and ESG 10/2 internal grilles.

Features

Nominal size	100 mm
Filter class	G2
Width	125 mm
Height	125 mm
Depth	10 mm
Packing unit	5 pieces

**Air filters, replacement
ALDF/ZEF**

Article	Art. No.	Filter class	Ambient temperature °C	Suitable for products
ALDF 10	0093.0154	G2	60	ALD 10
ALDF 10 T	0093.0155	G2	60	ALD 10 T
ALDF 12 G2	0093.0152	G2	60	ALD 12 S / ALD 12 SVA
ALDF 12 G3	0093.0153	G3	60	ALD 12 S / ALD 12 SVA
ALDF 125/160 G2	0093.0079	G2	60	ALD 125 / ALD 125 VA, ALD 160 / ALD 160 VA
ALDF 125/160 G3	0093.0080	G3	60	ALD 125 / ALD 125 VA, ALD 160 / ALD 160 VA
ZEF 45 F	0093.0020	G2	50	ZE 45 F white

- Replacement filter for outside air openings.

Article	Width mm	Height mm	Depth mm
ALDF 10	140	140	12
ALDF 10 T	95	95	65
ALDF 12 G2	140	140	12
ALDF 12 G3	140	140	12
ALDF 125/160 G2	95	95	12
ALDF 125/160 G3	170	180	5
ZEF 45 F	460	26	10

Common features

Packing unit	5 pieces
--------------	----------

**Air filter, replacement
WSG/WSF/ZF**

- Replacement air filter for ventilation units.

Article	Art. No.	Packing unit	Suitable for products
WSG 150	0093.0892	2 x G4	WS 150
WSF 170	0093.0271	1 x F7	WS 160 Flat, WS 170...
WSF-AKF 170	0093.0272	1 x active carbon, M5	WS 160 Flat, WS 170...
WSG 170	0093.0270	10 x G4	WS 160 Flat, WS 170...
WSF 250	0093.0890	2 x G4, 1 x F7	WS 250
WSG 250	0093.0891	2 x G4	WS 250
WSF 320/470	0092.0559	1 x F7	WS 320..., WS 470..., WR 310, WR 410
WSG 320/470	0092.0560	2 x G4	WS 320..., WS 470..., WR 310, WR 410
WSG-EG 320/470	0092.0562	10 x G4	WS 320..., WS 470..., WR 310, WR 410
WSF-AKF 320/470	0092.0563	1 x active carbon, M5	WS 320..., WS 470..., WR 310, WR 410
WSF 600	0093.0689	2 x G4, 1 x F7	WR 600
WSG 600-1	0093.0688	4 x G4	WR 600
WRF 180 EC	0093.0060	2 x G4	WRG 180 EC
WRF 180 EC-7	0093.0047	2 x F7	WRG 180 EC
WSF 300-400	0093.0898	2 x G4, 1 x F7	WR 300, WR 400
WSG 300-400	0093.0897	4 x G4	WR 300, WR 400
WRF 300-400 EC	0093.0061	2 x G4	WRG 300 EC, WRG 400 EC
WRF 300 DC	0093.0023	2 x G3	WRG 300 DC
WSG 600	0093.0886	2 x G4	WS 600
ZF 300	0093.0696	2 x G3	WRG 300, WRG 300 W, WRG 300 WP, WRG 300 WPK

Article	Width mm	Depth mm	Height mm
WSG 150	350	250	22
WSF 170	400	173	50
WSF-AKF 170	400	173	50
WSG 170	305	165	17
WSF 250	485	180	48
WSG 250	480	175	18
WSF 320/470	506	164	48
WSG 320/470	507	165	50
WSG-EG 320/470	505	170	18
WSF-AKF 320/470	507	163	48
WSF 600	435	375	48
WSG 600-1	430	370	14
WRF 180 EC	285	140	16
WRF 180 EC-7	288	138	23
WSF 300-400	425	175	48
WSG 300-400	410	170	14
WRF 300-400 EC	420	240	18
WRF 300 DC	420	240	10
WSG 600	485	295	20
ZF 300	435	150	10

**Push-in frame for air filter
WSG-ES 170**

- Push-in frame for WSG 170 air filter.
- Can consistently be re-used.
- Is needed if the WS 160 Flat or WS 170... is to be equipped with an extra G4 filter in the outside air.

Article	Art. No.
WSG-ES 170	0093.0269

Features

Width	300 mm
Height	165 mm
Depth	22 mm

**Push-in frame for air filter
WSG-ES 320/470**

- Push-in frame to position the WSG-EG 320/470 replacement air filter mats.

Article	Art. No.
WSG-ES 320/470	0092.0561

Features

Material	Steel, galvanised
Width	505 mm
Height	170 mm
Depth	20 mm

**Air filters, replacement
FF/PF**

- Replacement air filter for fresh air units.

Article	Art. No.	Filter class	Suitable for products
FF 100	0093.0652	G2	FLG 100, FLG 100 Z
PF 100	0093.0651	F7	POL 100, POL 100 Z

Article	Width mm	Height mm	Depth mm
FF 100	225	95	6
PF 100	225	95	3

Common features

Max. ambient temperature	40 °C
Packing unit	5 pieces

Replacement heat exchanger ring WRF 20

Article	Art. No.
WRF 20	0093.0347

- Replacement heat exchanger rings for WRG 20.

Features

Filter class	G2
Max. ambient temperature	40 °C
Diameter	200 mm
Width	560 mm
Height	75 mm
Depth	14 mm
Packing unit	5 pieces

Air filter, replacement ZF 35

Article	Art. No.
ZF 35	0093.0207

- Replacement air filter for DTH 35 AIROTHERM air heater.

Features

Nominal size	350 mm
Filter class	G3
Width	645 mm
Height	400 mm
Depth	18 mm
Packing unit	5 pieces

Air filters, replacement ECR-G4/ECR-F7

Article	Art. No.	Filter class
ECR 12-20 G4	0093.0893	G4
ECR 25-31 G4	0093.0894	G4
ECR 12-20 F7	0093.0895	F7
ECR 25-31 F7	0093.0896	F7

- Replacement air filter for ECR compact box.
- Filter change is possible without tools.

Article	Width mm	Height mm	Depth mm
ECR 12-20 G4	330	275	45
ECR 25-31 G4	390	315	45
ECR 12-20 F7	330	275	45
ECR 25-31 F7	390	335	50

Air filters, replacement KFF

Article	Art. No.	Filter class
KFF 6030-5	0093.1215	F5
KFF 6030-7	0093.1218	F7
KFF 9030-5	0093.1216	F5
KFF 9030-7	0093.1219	F7
KFF 9040-5	0093.1217	F5
KFF 9040-7	0093.1220	F7

- Replacement air filter for sound-insulated flat box for supply air KFR/KFD, KFR -K/ KFD -K and KFR -F/KFD -F.

Article	Width mm	Height mm	Depth mm
KFF 6030-5	592	287	96
KFF 6030-7	592	287	96
KFF 9030-5	892	287	96
KFF 9030-7	892	287	96
KFF 9040-5	892	387	96
KFF 9040-7	892	387	96

Common features

Depth	96 mm
-------	-------

Air filter, replacement SF 120

Article	Art. No.
SF 120	0093.0925

- Replacement filter for SG 120 external grille.

Features

Nominal size	120 mm
Filter class	G2
Width	140 mm
Height	140 mm
Depth	7 mm
Packing unit	5 pieces

Air filter, replacement AZP

Article	Art. No.
AZP	0093.0929

- Replacement filter for AZE 100 P.

Features

Filter class	PPI 20
Width	120 mm
Height	120 mm
Depth	8 mm
Packing unit	5 pieces

Main- / service- / reversing switches



Main switches, service switches HS



- Service switch in accordance with VDE 0113, part 1.
- Housing encapsulated in accordance with ISO.
- Switch can be locked in the OFF position.
- With 2 auxiliary contacts (1 N/C contact, 1 N/O contact).
- HS 3: 3-pole cam-operated switch for single speed fans or for speed-controlled fans.
- HS 6: 6-pole cam-operated switch for pole-changeable fans.

Article	Art. No.
HS 3	0157.0736
HS 6	0157.0737

Common features

U _{nom}	230 V/400 V
Degree of protection	IP 65
Maximum load	16 A
Type of installation	Surface-mounted
Width	82 mm
Height	82 mm
Depth	127 mm

Rotary switch DS 10



- Rotary switch for operating fans independently of a thermostat.
- Switch for switching on and switching between controlled and continuous operation.
- Switch positions: Continuous operation, Off, controlled operation.

Article	Art. No.
DS 10	0157.0410

Features

U _{nom}	230 V
f _{nom}	50 Hz/60 Hz
Degree of protection	IP 65
I _{max}	16 A
Type of installation	Surface-mounted
Width	82 mm
Height	82 mm
Depth	101 mm

Reversing switches W/WU



- Reversing switch for fan control.
- For alternating air direction.
- WU 1: With switch box for recessed mounting.

Article	Width mm	Height mm	Depth mm
W 1	82	82	127
WU 1	81	81	100

Common features

U _{nom}	230 V/400 V
f _{nom}	50 Hz/60 Hz
Maximum load	16 A
Colour	Light grey

Article	Art. No.	Degree of protection IP	Type of installation
W 1	0157.0101	65	Surface-mounted
WU 1	0157.0102	00	Recessed-mounted

**Pole-changing switches
P**



Article	Art. No.	Motor
P 1	0157.0103	Dahlander circuit
P 2	0157.0106	Separate windings

- Pole-changing switch for controlling pole-changeable fans.
- Step switch for 2 speeds.

Common features

U _{nom}	500 V
Degree of protection	IP 65
Maximum load	16 A
Type of installation	Surface-mounted
Width	82 mm
Height	82 mm
Depth	127 mm

**Reversing switches,
pole-changing switches
WP**



Article	Art. No.	Motor
WP 1	0157.0105	Dahlander circuit
WP 2	0157.0108	Separate windings

- Pole-changing switch for controlling pole-changeable fans.
- Step switch for 2 speeds.

Common features

U _{nom}	500 V
Degree of protection	IP 65
Maximum load	16 A
Type of installation	Surface-mounted
Air direction	Ventilation and air extraction
Width	82 mm
Height	82 mm
Depth	127 mm

**Step switch, reversing
switch
FS**



Article	Art. No.	f _{nom}	Maximum load (inductive load)	Air direction
		Hz	A	
FS 4	0016.0104	50	0.35	Ventilation or air extraction
FS 6	0016.0106	50	0.35	Ventilation/Air extraction
FS 7	0016.0107	50/60	6	Ventilation/Air extraction

- Step or reversing switch for controlling fans.
- With operating indicator light.
- FS 4: Step switch for 2 speeds.
- FS 6: 2-step reversing switch for ventilation and air extraction.
- FS 7: Reversing switch for ventilation and air extraction.

Common features

U _{nom}	230 V
Degree of protection	IP 20
Colour	Pearl white, similar to RAL 1013
Type of installation	Surface-mounted
Width	128 mm
Height	74 mm
Depth	46 mm

Motor protection switches, PTC thermistor triggering device, machine protection relay thermistor

Motor protection switch MVE/MV



- Motor protection switch for fans with fitted thermal contacts.
- With main contactor and control fuse.

Article	Art. No.	U _{nom}	Max-imum load	Min-imum load
		V	A	A
MVE 10	0157.0711	230	10	0.4
MV 25	0157.0712	400	25	-

Common features

f _{nom}	50 Hz/60 Hz
Degree of protection	IP 54
Type of installation	Surface-mounted
Width	75 mm
Height	140 mm
Depth	95 mm

PTC thermistor triggering device MVS 6

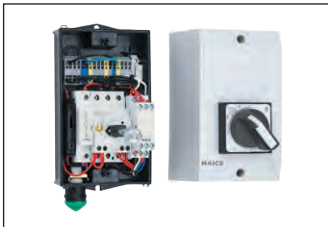

- Independent complete system.
- The PTC thermistor triggering device for monitoring the maximum motor temperature.
- Accessories needed for the DZ ... Ex e three-phase AC fans.
- Type-examination tested according to Directive 2014/34/EU.
- With operating indicator light.

Safety instructions

- Installation exclusively in non-explosive areas.

Features

U _{nom}	400 V
f _{nom}	50 Hz
Degree of protection	IP 65
I _{max}	6.3 A
Housing material	Synthetic material
Colour	Light grey
Max. ambient temperature	40 °C
Type of installation	Surface-mounted
Width	120 mm
Height	225 mm
Depth	240 mm
EX designation in accordance with standard	Ex II (2)G [Ex e]/Ex II (2)D [Ex t]

Article	Art. No.
MVS 6	0157.0585

Machine protection relay thermistor TMS



- The PTC thermistor triggering device for monitoring the maximum motor temperature.
- For installation in control cabinets.
- Accessories for the DZ ... Ex e three-phase AC fans.
- Type-examination tested according to Directive 2014/34/EU.
- 1 n/c (normally closed) contact and 1 n/o (normally open) contact.
- With mains and error LED display.
- With test button.

Safety instruction

- Installation exclusively in non-explosive areas.

Features

U _{nom}	24 V - 240 V
f _{nom}	50 Hz/60 Hz
Degree of protection	IP 20
I _{max}	3 A
Ambient temperature	-25 °C up to 60 °C
Type of installation	Control cabinet
Width	23 mm
Height	84 mm
Depth	104 mm
EX designation in accordance with standard	Ex II (2)D [Ex t]/Ex II (2)G [Ex e]

Article	Art. No.
TMS	0157.0992

**Motor protection switch
MVEx**

Article	Art. No.	Maximum load A
MVEx 0,4	0157.0547	0.4
MVEx 1,0	0157.0548	1
MVEx 1,6	0157.0549	1.6

- Motor safety switch to monitor the maximum motor current.
- Necessary accessories for EZQ/EZS 20/4 E Ex e and ERM ... Ex e.
- Type-examination tested according to Directive 2014/34/EU.

Safety instructions

- Installation exclusively in non-explosive areas.

Common features

U _{nom}	230 V
f _{nom}	50 Hz/60 Hz
Degree of protection	IP 20
Housing material	Synthetic material
Colour	Light grey
Type of installation	Control cabinet
Width	45 mm
Height	93 mm
Depth	76 mm

**Contactor
US 16 T**

Article	Art. No.
US 16 T	0157.0769

- Universal contactor for controlling fans and/or for loads.
- Control voltage: 230 V/50 Hz, 240 V/60 Hz.
- With 3 main contacts, 1 auxiliary contact (N/C contact).
- Water and dust protected.
- With integrated 35 mm profile rail.

Features

U _{nom}	600 V
Degree of protection	IP 55
Maximum load (ohmic load)	16 A
Type of installation	Surface-mounted
Width	100 mm
Height	160 mm
Depth	145 mm

**Potentiometer
ST EC**

Article	Art. No.	U _{nom} V
ST EC 010	0157.0110	10
ST EC 230	0157.0109	230
ST EC 3	0157.0111	10 - 15



- Potentiometer for controlling EC fans.
- Output voltage for ST EC 10 and ST EC 230 can be set in continuously variable manner between 0 - 10 V using rotary knob.
- ST EC 3 permits regulation of output voltage over 3 levels:
 - Level 1 = 3 - 7 V can be set
 - Level 2 = 5 - 9 V can be set
 - Level 3 = 10 V
- The potentiometer can be fitted in both a recessed-mounted box without housing (IP 44) and surface-mounted with the housing (IP 54).
- Additional switching contact for ST EC 010 permits e.g. a controller release to be connected.
- ST EC 230 for connection to a 230 V power supply.
- ST EC 010 for connection to a 10 V power supply.
- ST EC 3 for connection to a 10 - 15 V power supply.

Common features

Output signal	0 V - 10 V
Degree of protection	IP 54
Housing material	Synthetic material
Colour	Pure white, similar to RAL 9010
Type of installation	Surface-mounted/ Recessed-mounted
Width	82 mm
Height	82 mm
Depth	65 mm

Infinitely adjustable speed controllers

Speed controllers
ST

Article	Art. No.	Maximum load A	Minimum load A
ST 1	0157.0810	1	0.1
ST 2,5	0157.0811	2.5	0.1
ST 5	0157.0812	4.3	0.2

- Speed controller for linear control of the fans.
- Minimum speed adjustable.
- Function principle: Phase angle control.
- Recommended distance from radios and televisions: 3 m.
- Switch on the fans at maximum speed by turning the knob. Turning further reduces the speed.
- Splash water protected.
- With operating indicator light.
- VDE-tested.
- Additional switching contact (230 V) e.g. for controlling a shutter.
- There can be a physically induced humming noise at lower speeds, through the use of phase angle technology. TRE... 5-step transformers are therefore used for speed control in rooms requiring quiet fan operations.
- Assembly on walls possible; avoid ceiling installation because of temperature build-up.

Article	Width mm	Height mm	Depth mm
ST 1	81	81	63
ST 2,5	81	81	63
ST 5	85	170	63

Common features

U _{nom}	230 V
Degree of protection	IP 44
Colour	Pure white, similar to RAL 9010
Type of installation	Surface-mounted

Speed controllers
STU

Article	Art. No.	Maximum load A	Minimum load A
STU 1	0157.0814	1	0.1
STU 2,5	0157.0815	2.5	0.1
STU 5	0157.0816	4.3	0.2

- Speed controller for linear control of the fans.
- Minimum speed adjustable.
- Function principle: Phase angle control.
- Recommended distance from radios and televisions: 3 m.
- Switch on the fans at maximum speed by turning the knob. Turning further reduces the speed.
- With operating indicator light.
- VDE-tested.
- Additional switching contact (230 V) e.g. for controlling a shutter.
- There can be a physically induced humming noise at lower speeds, through the use of phase angle technology. TRE... 5-step transformers are therefore used for speed control in rooms requiring quiet fan operations.
- Assembly on walls possible; avoid ceiling installation because of temperature build-up.

Article	Width mm	Height mm	Depth mm
STU 1	81	81	56
STU 2,5	81	81	56
STU 5	81	152	64

Common features

U _{nom}	230 V
Degree of protection	IP 20
Colour	Pure white, similar to RAL 9010
Type of installation	Recessed-mounted

Reversing switch
UWK 1

Article	Art. No.
UWK 1	0157.0817

- Reversing switch for ventilation and air extraction.
- With masking frame for combination with STU 1 or STU 2.5.

Features

U _{nom}	230 V
f _{nom}	50 Hz/60 Hz
I _{max}	1 A
Colour	Alpine white
Type of installation	Recessed-mounted
Width	80 mm
Height	150 mm
Depth	10 mm

**Speed controller,
distribution board
STS 2,5**

Article	Art. No.
STS 2,5	0157.0255

- Speed controller for linear control of the fans.
- VDE-tested.
- For one rotational direction.
- It is possible to fit using a 68 mm or a 35 mm standard profile rail.
- There can be a physically induced humming noise at lower speeds, through the use of phase angle technology. TRE... 5-step transformers are therefore used for speed control in rooms requiring quiet fan operations.

Features

U _{nom}	230 V
Maximum load	2.5 A
Minimum load	0.1 A
Colour	light grey
Type of installation	Distribution board/ Control cabinet
Width	52 mm
Height	71 mm
Depth	57.5 mm

**Speed controllers,
reversing switch
STW**

Article	Art. No.	Maximum load A
STW 1	0157.0813	1
STW 2,5	0016.0142	2.5

- For air extraction and ventilation.
- With operating indicator light.
- VDE-tested.
- Additional switching contact (230 V) e.g. for controlling a shutter.
- There can be a physically induced humming noise at lower speeds, through the use of phase angle technology. TRE... 5-step transformers are therefore used for speed control in rooms requiring quiet fan operations.

Common features

U _{nom}	230 V
Degree of protection	IP 20
Minimum load	0.1 A
Colour	Pearl white, similar to RAL 1013
Type of installation	Surface-mounted
Width	128 mm
Height	74 mm
Depth	54 mm

**Frequency converter
MFU**

Article	Art. No.	I _{nom} A	Recommended motor power W
MFU 1	0157.1214	1.4	550
MFU 2	0157.1215	2.6	750
MFU 4	0157.1216	4.3	1,500
MFU 6	0157.1217	6	2,200
MFU 10	0157.1218	9.6	3,700
MFU 14	0157.1219	14	5,500
MFU 19	0157.1220	19	7,500

- Frequency converter for controlling fan speed in continuously variable manner.
- With mains filter and extra terminal block.
- With motor protection switch via thermal contact or PTC thermistor.
- Control inputs: electrically isolated, PLC-compatible, freely programmable.
- Nominal value inputs: 0 - 5 V, 0 - 10 V, 0(4) - 20 mA with voltage and current offset calibration function.
- Nominal value output: 1 analogue output 0 - 10 V.
- Digital inputs: 6, some of which are freely programmable.
- Signal outputs: 2, some of which are freely programmable.
- Digital outputs: 2 potential-free outputs for fault and operating messages (changeover contact).
- Connections using metric screw connections 2 x PG 12, 2 x PG 16.
- Preset in the factory for 15 programmable fixed speeds.
- Service life of around 80 000 hours at 80 to 85 % nominal load.
- Suitable for DSK, DAS, EDR 56/63/71 and all DZ... fans with phase isolation (special version).
- ST EC 010 can also be used for remote maintenance.

Article	Width mm	Height mm	Depth mm
MFU 1	200	350	157
MFU 2	200	350	157
MFU 4	200	350	157
MFU 6	200	350	172
MFU 10	200	350	172
MFU 14	260	710	300
MFU 19	260	710	300

Common features

U _{nom}	3 x 380 V to 480 V (+/- 10%)
f _{nom}	50 Hz/60 Hz
Degree of protection	IP 54
Housing material	Sheet steel, galvanised
Colour	Light grey, similar to RAL 7035
Ambient temperature	-10 °C up to 50 °C

5-step transformers



5-step transformers TRE-2



- 5-step transformers for setting speed.
- To control AC fans.
- With operating indicator light.
- Additional switching contact (230 V) e.g. for controlling a shutter.

Article	Art. No.	P _{nom}	
		W	A
TRE 0,4-2	0157.0156	72	0.4
TRE 0,6-2	0157.0157	108	0.6
TRE 1,6-2	0157.0158	288	1.6
TRE 3,3-2	0157.0159	594	3.3
TRE 6,5-2	0157.0160	1,170	6.5
TRE 10-2	0157.0161	1,800	10

Article	Width mm	Height mm	Depth mm
TRE 0,4-2	195	148	175
TRE 0,6-2	195	148	175
TRE 1,6-2	195	148	175
TRE 3,3-2	195	148	175
TRE 6,5-2	248	195	205
TRE 10-2	248	195	205

Common features

U _{nom}	230 V
f _{nom}	50 Hz/60 Hz
Degree of protection	IP 54
Secondary voltage	85 / 115 / 150 / 180 / 230 V
Housing material	Synthetic material
Colour	Light grey, similar to RAL 7035
Ambient temperature	0 °C up to 40 °C
Type of installation	Surface-mounted

5-step transformers TR-2



- 5-step transformers for setting speed.
- To control three-phase AC fans.
- With operating indicator light.

Article	Art. No.	P _{nom}		Housing material
		W	A	
TR 0,4-2	0157.0147	200	0.4	Synthetic material
TR 0,8-2	0157.0148	400	0.8	Synthetic material
TR 2,5-2	0157.0149	1,250	2.5	Synthetic material
TR 6,6-2	0157.0150	3,300	6.6	Metal

Article	Width mm	Height mm	Depth mm
TR 0,4-2	248	195	205
TR 0,8-2	248	195	205
TR 2,5-2	310	228	225
TR 6,6-2	400	300	240

Common features

U _{nom}	400 V
f _{nom}	50 Hz/60 Hz
Degree of protection	IP 54
Secondary voltage	105 / 150 / 190 / 250 / 400 V
Colour	Light grey, similar to RAL 7035
Ambient temperature	0 °C up to 40 °C
Type of installation	Surface-mounted

**5-step transformers,
control cabinet
TRE S-2**

Article	Art. No.	P _{nom} W	Max- imum load
			A
TRE 1,6 S-2	0157.0162	288	1.6
TRE 3,3 S-2	0157.0163	594	3.3
TRE 6,5 S-2	0157.0164	1,170	6.5

- 5-step transformers for setting speed.
- To control AC fans.
- With foot bracket and connection terminals.
- With profile rail for integral transformers < 3 kg.
- Accessories: ESS 20 5-step switch

Article	Width mm	Height mm	Depth mm
TRE 1,6 S-2	84	75	95
TRE 3,3 S-2	105	80	110
TRE 6,5 S-2	120	100	120

Common features

U _{nom}	230 V
f _{nom}	50 Hz/60 Hz
Degree of protection	IP 00
Secondary voltage	85 / 115 / 150 / 180 / 230 V
Ambient temperature	0 °C up to 40 °C
Type of installation	Control cabinet

**5-step transformers,
control cabinet
TR S-2**

Article	Art. No.	P _{nom} W	Max- imum load
			A
TR 0,8 S-2	0157.0151	144	0.8
TR 2,5 S-2	0157.0152	450	2.5
TR 6,6 S-2	0157.0153	1,188	6.6

- 5-step transformers for setting speed.
- To control three-phase AC fans.
- With foot bracket and connection terminals.
- With profile rail for integral transformers < 3 kg.
- Accessories: DSS 20 5-step switch.

Article	Width mm	Height mm	Depth mm
TR 0,8 S-2	84	75	95
TR 2,5 S-2	120	90	120
TR 6,6 S-2	150	115	155

Common features

U _{nom}	400 V
f _{nom}	50 Hz/60 Hz
Degree of protection	IP 00
Secondary voltage	105 / 150 / 190 / 250 / 400 V
Ambient temperature	0 °C up to 40 °C
Type of installation	Control cabinet
Packing unit	2 pieces

**5-step switch for
TRE...S -2/ TR...S-2
5-step transformers
ESS/DSS**

Article	Art. No.	U _{nom} V
ESS 20	0157.0749	230
DSS 20	0157.0750	400

- 5-step switch for TRE...S-2 and TR...S-2 5-step transformers.
- For front-mounting in the control cabinet.
- ESS: Accessories for AC fans.
- DSS: Accessories for three-phase AC fans.

Article	Width mm	Height mm	Depth mm
ESS 20	72	72	81
DSS 20	72	72	133

Common features

f _{nom}	50 Hz/60 Hz
Degree of protection	IP 00
Maximum load	20 A
Ambient temperature	0 °C up to 40 °C
Type of installation	Control cabinet

3-step switch, time delay switches, interval switch

3-step switch DS 3N



- Rotary switch for controlling 3-step ventilation units (e.g. ER 100 D exhaust air fan).
- Suitable for standard recessed-mounted boxes.
- With zero setting.

Article	Art. No.
DS 3N	0157.0186

Features

U_{nom}	230 V
Degree of protection	IP 30
Maximum load	16 A
Colour	polar white, similar to RAL 9010, matt
Type of installation	Recessed-mounted
Width	80 mm
Height	80 mm
Depth	32 mm

Time delay switches VZ

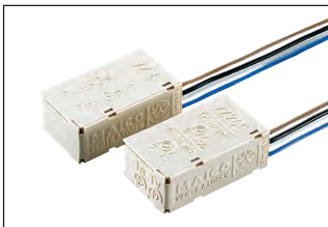

- Time delay switch for controlling the start delay and overrun time of fans.
- Operation possible through standard switch.
- VZ 24 C: Operation possible through standard switch or button.
- Interference suppression in accordance with EN 61000-4-5 (for 1000 V to 4000 V). Additional interference suppression measures (L, C components or RC module, protection diodes, varistors) can be fitted, if required.
- Mark of conformity: VDE.

Article	Art. No.	Start delay s	Overrun time min
VZ 6	0157.0820	50	6
VZ 12	0157.0821	50	12
VZ 24 C	0157.0822	0 - 150	1.5 - 24

Common features

U_{nom}	230 V
f_{nom}	50 Hz/60 Hz
Degree of protection	IP 40
Maximum load	1.25 A
Ambient temperature	0 °C up to 50 °C
Width	20 mm
Height	13 mm
Depth	35 mm

Interval switch VZI 10



- Interval switch for regular ventilation of seldom used rooms.
- The fan can be switched on using the interval switch or manually.
- Operation possible through standard switch.
- Adjustable interval: 1 h to 15 h.
- Can be fitted in a recessed-mounted box.
- Mark of conformity: VDE.

Article	Art. No.
VZI 10	0157.0823

Features

U_{nom}	230 V
f_{nom}	50 Hz/60 Hz
Degree of protection	IP 40
Maximum load	1.25 A
Ambient temperature	0 °C up to 50 °C
Start delay	50 s
Overrun time	10 min
Width	20 mm
Height	13 mm
Depth	35 mm

**Follow-up relay
NRS 10**

Article	Art. No.
NRS 10	0157.0805

- Follow-up relay for setting the overrun time of fans.
- Activation by means of commercial on/off-switches, push buttons and door contact switches is possible.
- Side air gaps are necessary for thermal reasons.

Features

U_{nom}	230 V
f_{nom}	50 Hz/60 Hz
Degree of protection	IP 20
Maximum load (inductive load)	2.5 A
Maximum load (ohmic load)	10 A
Overrun time	0.5 min - 20 min
Type of installation	Control cabinet
Width	17.5 mm
Height	90 mm
Depth	73 mm

**Timer
ZS 4**

Article	Art. No.
ZS 4	0157.0088

- Two-channel timer for installation in distributor.
- Can be programmed without mains connection (6 years of power reserve).
- Text-based menu guidance and self-explanatory icons/symbols.
- Large and clear display with two high-resolution rows of text (matrix of dots).
- Easy to use. Quick and intuitive to program.
- 46 memory spaces.
- Day and week program.
- Holiday and impulse program.
- Permanent switching by date.
- Manual permanent switching.
- Manual switching forestalling.
- Automatic switching time orientation when reading.
- Automatic summer time setting.
- Display of device operating hours and per channel.
- Security by means of PIN coding.
- 2 changeover contacts.
- Shortest switching spacing of 1 min.
- Switching capacity 16 A / 250 V.

Features

U_{nom}	230 V
f_{nom}	50 Hz/60 Hz
Degree of protection	IP 20
Housing material	Synthetic material
Ambient temperature	-10 °C up to 55 °C
Electrical plug-type connection	Screw connection
Type of installation	Distribution board
Width	36 mm
Height	90 mm
Depth	58 mm

**Thermostat
THR 10**

Article	Art. No.
THR 10	0157.0774

- Thermostat for controlling fans depending on the air temperature.
- With automatic change over for summer / winter operation.
- An US 16 T universal contactor is required for switching the three-phase AC fans.

Features

U_{nom}	230 V
Degree of protection	IP 30
Maximum load (inductive load)	2 A
Maximum load (ohmic load)	10 A
Colour	Pearl white, similar to RAL 1013
Temperature setting range	10 °C up to 30 °C
Differential gap	approx. 1 K
Type of installation	Surface-mounted
Width	76 mm
Height	82 mm
Depth	38 mm

Thermostat TH 10



Article	Art. No.
TH 10	0157.0764

- Thermostat for controlling fans depending on the air temperature.
- It is possible to operate the fan with increasing or decreasing air temperature (changeover contact).
- With switching status display fitted on the inner side.
- Interference suppression in accordance with VDE 0875, interference level N.
- Temperature sensor with 2 m connecting cable.

Features

U_{nom}	230 V
Degree of protection	IP 54
Maximum load (inductive load)	4 A
Maximum load (ohmic load)	10 A
Max. ambient temperature	50 °C
Temperature setting range	-10 °C up to 30 °C
Differential gap	approx. 0.2 K to 5 K
Type of installation	Surface-mounted
Width	125 mm
Height	110 mm
Depth	69 mm

Thermostat TH 16



Article	Art. No.
TH 16	0157.0748

- Thermostat for controlling fans depending on the air temperature.
- It is possible to operate the fan with increasing or decreasing air temperature (changeover contact).
- An US 16 T universal contactor is required for switching the three-phase AC fans.
- VDE, SEV, Semko and Nemko tested.
- Accessories: DS 10 rotary switch for operating fans independently of the thermostat.

Features

U_{nom}	230 V
Degree of protection	IP 54
Maximum load (inductive load)	4 A
Maximum load (ohmic load)	16 A
Max. ambient temperature	50 °C
Temperature setting range	0 °C up to 50 °C
Differential gap	approx. 1.5 K
Type of installation	Surface-mounted
Width	115 mm
Height	150 mm
Depth	68 mm

Thermostat THD 10



Article	Art. No.
THD 10	0157.0775

- Thermostat for controlling fans depending on difference in temperature.
- With 2 temperature sensors.
- The thermostat switches depending on one temperature sensor located on the floor and one on the ceiling in an occupied area.

Features

U_{nom}	230 V
Degree of protection	IP 54
Maximum load	10 A
Max. ambient temperature	40 °C
Temperature setting range	5 °C up to 35 °C
Differential gap	approx. 2 K
Type of installation	Surface-mounted
Width	125 mm
Height	195 mm
Depth	110 mm

**Pressure and temperature control system
EAT EC**

Article **Art. No.**
EAT EC **0157.0119**



- Versatile electronic control system for controlling one or two EC fans in continuously variable manner.
- Depending on the sensors connected, temperature, differential temperature or pressure control is possible.
- Five operating modes available: Automatic/manual mode/continuous operation/inactive or off.
- Different control inputs for temperature sensors and also active sensors, such as pressure sensors with 0-10 V signal.
- Temperature sensor included in the scope of delivery.
- Two controlled output signals of 0-10 V as control signal for one or two EC fans.
- Option for connecting shutter servomotors (230 V or 24 V).
- 2 pressure values can be specified (day/night).
- Alarm contact.
- Timer with daily and weekly program.
- Quick and easy start-up thanks to illuminated two-line digital display with plain text display and membrane keypad.
- Very little power consumption.

Features

U _{nom}	230 V
Output signal	0 V - 10 V
Voltage at the output	1 x 24 AC 2,8 VA
f _{nom}	50 Hz
Degree of protection	IP 54
Operating range	0 - 500 Pa / 0 - 1000 Pa
Housing material	Synthetic material
Max. ambient temperature	40 °C
Temperature setting range	0 °C up to 40 °C
Type of installation	Surface-mounted

**Temperature control system
EAT 6 G/1**

Article **Art. No.**
EAT 6 G/1 **0157.0808**

- Electrical 2 point temperature controller for controlling AC fans.
- Proportional sector: 2 K to 10 K.
- With 0 V to 10 V outlet for additional system components, e.g. EALT 6, MFU or GLT power module.
- Temperature sensor included in the scope of delivery.
- Function principle: Phase angle control.
- There can be a physically induced humming noise at lower speeds, through the use of phase angle technology. 5-step transformers are therefore used for speed control in rooms requiring quiet fan operations.

Features

U _{nom}	230 V
f _{nom}	50 Hz/60 Hz
Degree of protection	IP 54
Maximum load	6 A
Minimum load	0.2 A
Housing material	Synthetic material
Max. ambient temperature	40 °C
Temperature setting range	5 °C up to 35 °C
Type of installation	Surface-mounted
Width	188 mm
Height	160 mm
Depth	110 mm

**Temperature control system
EAT 6 TG**

Article **Art. No.**
EAT 6 TG **0157.0755**

- Electrical 2 point temperature controller for controlling AC fans.
- With 0 V to 10 V outlet for additional system components, e.g. EALT 6, MFU or GLT power module.
- With digital display for actual and setpoint temperatures.
- With analogue display for the output voltage.
- With heating thermostat for controlling an air heater.
- With output for alarm signals to indicate excessive temperature and insufficient temperature as well as loss of voltage. n/c (normally closed) contact and n/o (normally open) contact without potential.
- With motor starting assistance: Forced start-up at maximum speed. After a successful start, the speed is reduced to setpoint value.
- Proportional sector: 2 K to 10 K.
- Temperature sensor included in the scope of delivery.
- Function principle: Phase angle control.
- There can be a physically induced humming noise at lower speeds, through the use of phase angle technology. 5-step transformers are therefore used for speed control in rooms requiring quiet fan operations.

Features

U _{nom}	230 V
f _{nom}	50 Hz/60 Hz
Degree of protection	IP 54
Maximum load	6 A
Minimum load	0.2 A
Housing material	Synthetic material
Max. ambient temperature	40 °C
Temperature setting range	5 °C up to 35 °C
Type of installation	Surface-mounted
Width	188 mm
Height	160 mm
Depth	110 mm

Temperature control systems, power board, channel sensor



Temperature control systems
ETL/DTL



- Electronic temperature controller for controlling the ERH, DRH electrical air heaters.
- With integrated sensor for measuring the room temperature.
- Optional control of supply air temperature or room temperature.
- Triac regulator with pulse packet control.
- Pulse period: 60 s.
- Night reduction can be set from 0 K to 10 K below the setpoint temperature.
- DTL 16 P: With additional input for setting minimum or maximum supply air temperatures. Possible only in combination with FL 30 P channel sensor.
- Accessories: FL 30 P channel sensor for measuring the air temperature in ventilation channels; FR 30 P room sensor for measurements in enclosed areas.

Article	Art. No.	U _{nom} V
ETL 16 P	0157.0824	230
DTL 16 P	0157.0825	400

Common features

f _{nom}	50 Hz/60 Hz
Degree of protection	IP 20
Maximum load	16 A
Type of installation	Surface-mounted
Width	93 mm
Height	153 mm
Depth	40 mm

Temperature control system
DTL 24 P



- Electronic temperature controller for controlling the DHP electrical air heater.
- Night reduction can be set from 0 K to 4 K below the setpoint temperature.
- Triac regulator with pulse packet control.
- Control via 0 V to 10 V possible.
- To increase power up to 30 kW, use DTL 2 P-L.

Article	Art. No.
DTL 24 P	0157.0586

Features

U _{nom}	400 V
Degree of protection	IP 20
Maximum load	24 A
Type of installation	Surface-mounted
Width	200 mm
Height	290 mm
Depth	195 mm

Power board
DTL 2 P-L

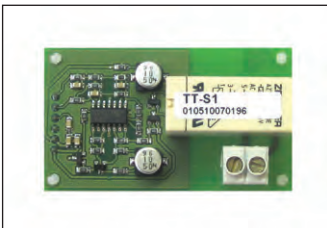

- Additional board for installation in the DTL 24 P electronic temperature control to meet a power requirement of 16.5 kW to 30 kW.

Article	Art. No.
DTL 2 P-L	0157.0587

Features

U _{nom}	400 V
Width	60 mm
Height	35 mm
Depth	30 mm

Channel sensor
FL 30 P



- Temperature sensor for measuring the air temperature in air channels.
- Can be combined with ETL 16 P, DTL 16 P, DTL 24 P.

Article	Art. No.
FL 30 P	0157.0780

Features

Degree of protection	IP 20
Material	Synthetic material
Temperature setting range	0 °C up to 30 °C
Installation site	Channel

**Room sensor
FR 30 P**

Article	Art. No.
FR 30 P	0157.0781

- Temperature sensor for measuring the air temperature in enclosed areas.
- Can be combined with ETL 16 P, DTL 16 P, DTL 24 P.

Features

Degree of protection	IP 20
Housing material	Synthetic material
Colour	Pure white, similar to RAL 9010
Temperature setting range	0 °C up to 30 °C
Type of installation	Surface-mounted
Width	86 mm
Height	86 mm
Depth	30 mm

**Air flow monitor
LW 9**

Article	Art. No.
LW 9	0157.0779

- Air flow monitor for monitoring the minimum volumetric flows in the ventilation systems.
- Sensor cable length: 2.5 m.
- Screened cables must be used if the sensor cable is located in a cable duct.
- The sensor records the air flow and compares it to the setpoint value in the control unit.
- Control unit: Installation on a 35 mm profile rail.
- With LED function display for relay outputs and nominal voltages.
- Working and closed circuit function selection switch.
- With potential-free output via a changeover contact, e.g. for operating or fault messages.

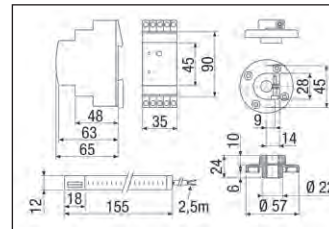
Dimensions [mm]

Features

Degree of protection	IP 10
Maximum load (inductive load)	2 A
Maximum load (ohmic load)	5 A
Min. flow velocity	1 m/s
Max. flow velocity	20 m/s
Max. ambient temperature	60 °C
Installation site	Channel

**Humidity and temperature sensor
FFT 30 K**

Article	Art. No.
FFT 30 K	0157.0121

- The humidity and temperature sensor serves to measure the relative humidity and temperature in closed rooms and is equipped with the standard 1...10V output signal.
- The sensor is fixed to the wall with screws (not supplied).
- Accessories: Safety isolating transformer (230 V / 24 V) to be provided by customer.

Features

U _{nom}	12...34 V AC/DC
Degree of protection	IP 30
Load	10 / 100 kOhm
Housing material	ABS plastic
Colour	Pure white, similar to RAL 9010
Relative humidity measurement range	0 % up to 98 %
Relative humidity output signal	0 V/10 V
Temperature measurement range	0 °C up to 50 °C
Temperature output	0 V/10 V
Electrical connection	Screw terminals
Connection terminal diameter	0.75 mm
Width	87.5 mm
Height	87.5 mm
Depth	30 mm

Sensors



**Hygrostats
HY 230**



Article	Art. No.	Operating element
HY 230	0157.0126	outside
HY 230 I	0157.0127	inside

- The HY 230 and/or HY 230 I electronic hygrostat is used to dehumidify or dampen closed rooms. It is suitable for all living areas and commercial premises, even for damp rooms such as bathrooms (please note degree of protection when installing), wash rooms and drying rooms.
- The hygrostat has an internal sensor for recording the room humidity and switches the fans, heat recovery units / dampening or dehumidifying units on and off depending on the set setpoint.
- The HY 230 and/or HY 230 I is either fitted directly on a recessed-mounted box or on the wall using the APM HY 230 surface-mounted installation kit.
- A DIP switch on the circuit board can be used to define the dehumidification (factory setting) or dampening operating mode upon commissioning.
- A red LED in the housing indicates the switching status of the relay.

Common features

U _{nom}	230 V
Output	230 V
f _{nom}	50 Hz
Degree of protection	IP 30
Max. permissible switched current	10 A/cos φ = 1, 230 V AC 4 A/cos φ = 0.6, 230 V AC
Max. permissible switch-on current	16 A
Material	Synthetic material
Colour	Pure white, similar to RAL 9010
Ambient temperature	0 °C up to 50 °C
Relative humidity measurement range	20 % up to 80 %
Type of installation	Surface-mounted
Sensor tolerance, relative humidity	5 %
Differential gap, relative humidity	2.5 %
Width	71 mm
Height	71 mm
Depth	27 mm

**Surface-mounted installation kit
APM HY 230**



Article	Art. No.
APM HY 230	0093.0159

- For surface mounting HY 230 and HY 230 I, e.g. if there is no recessed-mounted box available.
- Scope of delivery: The surface-mounted installation kit is supplied with four screws, which are provided for installing the spacing frame and HY lower part of the housing.

Mounting instructions

- The surface-mounted installation kit is only intended for introducing permanently routed cables into dry closed rooms.
- VDE 0100, EN 60730 Part 1 and the regulations laid down by local utility companies should be noted.
- The surface-mounted frame should be installed so that the HY 230 / HY 230 I can record the average room air humidity (avoid installing close to supply and exhaust air channels, windows and doors.) Installation on inside walls approx. 1.3 to 1.5 m above the floor (avoid direct sunlight).

Features

Material	Synthetic material
Colour	Pure white, similar to RAL 9010
Width	80 mm
Height	80 mm
Depth	29 mm

**Surface-mounted frame
frame APM HY 230**



Article	Art. No.
frame APM HY 230	0093.0164

- Frame for HY 230 and HY 230 I hygrostats.
- Can be used to cover the edge of recessed-mounted boxes which are too wide.

Features

Material	Synthetic material
Colour	Pure white, similar to RAL 9010
Type of installation	Surface-mounted
Width	79 mm
Height	79 mm
Depth	11 mm

**CO₂ sensor
SKD**

Article	Art. No.
SKD	0157.0345

- CO₂ sensor for controlling fans depending on concentration of CO₂ concentration.
- Visual sensor using infra-red absorption.
- With 5 LEDs for indicating CO₂ concentration.
- With 0 V to 10 V output for outputting CO₂ concentration.
- With 0 V to 10 V output for outputting temperature.
- Do not use for gas measurements of relevance to safety.
- Accessories: Safety isolating transformer (230 V / 24 V) to be provided by customer.

Features

U _{nom}	14 V - 48 V DC / 16 V - 36 V AC
Degree of protection	IP 20
I _{max}	0.1 A
I _{nom}	0.02 A
Housing material	Synthetic material
Colour	Pure white, similar to RAL 9010
Ambient temperature	10 °C up to 40 °C
Type of installation	Surface-mounted
Installation site	Wall
CO ₂ measuring range	500 ppm - 2,000 ppm
Width	79 mm
Height	120 mm
Depth	30 mm

**Air quality controller
EAQ 10/1**

Article	Art. No.
EAQ 10/1	0157.0777

- Air quality controller for operating fans depending on the air quality.
- With integrated air quality sensor for measuring the concentration of various gases and odours (e.g. carbon monoxide, methane, hydrogen, alcohol, tobacco smoke).
- The sensitivity can be continuously set using a potentiometer.
- Preset at factory.
- With 2 LEDs to display the operating state and the air quality.
- Ready after approx. 5 min.
- Reaction time: < 1 min.
- Overrun time: 1 to 3 minutes (depending on the degree of pollution).

Features

U _{nom}	230 V
Degree of protection	IP 30
Maximum load	10 A
Housing material	Synthetic material
Colour	Pure white, similar to RAL 9010
Type of installation	Surface-mounted
Installation site	Wall
Width	126 mm
Height	74 mm
Depth	24 mm

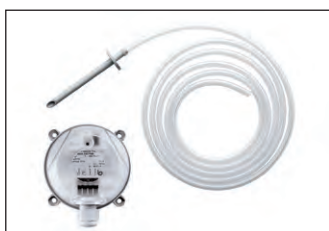
**Differential pressure transmitter
DS 500**

Article	Art. No.
DS 500	0157.0118

- Pressure transmitter in plastic housing for use in air and non-aggressive gases.
- Output signal of between 0-10 V (upon delivery) and 4-20 mA can be selected.
- Activation time can also be selected: 1 s (upon delivery) or 100 ms.
- Scope of delivery:
 - 1 x pressure transmitter
 - 2 x plastic pressure probes
 - 1 x 2 m PVC hose

Features

U _{nom}	18 V - 30 V DC
Output signal	0 V - 10 V
Degree of protection	IP 54
Operating range	0 - 500 Pa / 0 - 1000 Pa
Max. excess pressure	20 kPa

Room air control, radio switch



Differential pressure controller DW 1000



Article Art. No.
DW 1000 0157.0752

- Differential pressure controller for monitoring filter, fan and system pressure in ventilation systems.
- Switchover contact for switched current max. 5 A, 250 V AC and 0.8 A for inductive loads or 2 A, 30 V DC.
- Setpoint range: 100 Pa to 1000 Pa.
- Media: Air and non-aggressive gas.
- Electrical connection with PG 11 cable screw-connections and screw terminals.
- Packing unit: Pressure switch with hose couplings, adjustable scale in mbar, installation bracket, 2 m hose connection set.
- Accessories for TFE and TFP air filters.

Dimensions [mm]

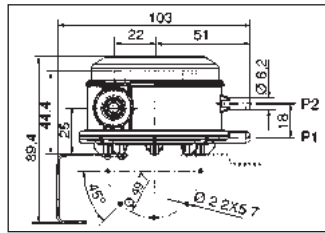

Features

Degree of protection	IP 54
Max. ambient temperature	85 °C

Room air control RLS 3



Article Art. No.
RLS 3 0157.0831

- Three-step room air control for ER 100 D exhaust air fan, ZEG 2000 P exhaust air unit and HDR EC duct fan.
- 3 switching steps: Base load, Normal, Full-load (rotary knob).
- With separate, 2-pole on/off switch (rocker switch).
- Both switches in joint double frame.

Features

U _{nom}	230 V
Degree of protection	IP 30
Maximum load	10 A
Material	Synthetic material
Type of installation	Recessed-mounted
Width	150 mm
Height	80 mm
Depth	32 mm

Radio switch XS 1



Article Art. No.
XS 1 0157.0344

- Radio switch for location-independent switching of AC fans or other consumers, such as light, circulation pump, etc.
- For redevelopments and retrofit installations. No painting or wallpapering.
- Tiles don't need to be removed or renewed.
- Application wherever no control cable can be installed.
- Radio switch can be used on the move.
- Radio switch can be screwed on or attached to a glass surface.
- Simple transmitter teaching-in saves on time-consuming programming.
- Batteries included in scope of delivery.
- Radio system consists of XS 1 radio switch and at least one XE 1 radio receiver.

Features

Battery	2 x 3 V
Radio frequency	433 MHz
Mains cable	not required
Transmission range in the building	30 m
Colour	Pure white, similar to RAL 9010
Type of installation	Surface-mounted
Width	88 mm
Height	88 mm
Depth	32 mm

Radio receiver XE 1



Article Art. No.
XE 1 0157.0343

- Radio receiver for a wireless connection from the switch to the fan.
- Installation in standard recessed-mounting box or distribution box.
- Radio system consists of XS 1 radio switch and at least one XE 1 radio receiver.
- An XS 1 can be assigned any number of XE 1.

Features

U _{nom}	230 V
Degree of protection	IP 20
Maximum load (inductive load)	2 A
Maximum load (ohmic load)	4 A
Radio frequency	433 MHz
Colour	Blue
Max. ambient temperature	55 °C
Type of installation	Recessed-mounted
Width	52 mm
Height	52 mm
Depth	21 mm



Located at
Villingen-Schwenningen
in the scenic Black Forest.



Maico Elektroapparate-Fabrik GmbH

Steinbeisstraße 20
78056 Villingen-Schwenningen
Germany

Telephone numbers:

Sales: + 49 77 20 / 694-255 or 227

Order processing: + 49 77 20 / 694-372 or 393

User Help Desk: + 49 77 20 / 694-392 or 393

Telefax: + 49 77 20 / 694-177

www.maico-fans.com

sales@maico.de

